

22-54

APRIL 19, 1971

\* LUNAR ROVING VEHICLE  
OPERATIONS HANDBOOK  
CONTRACT NAS8-25145

APPROVED: Albert Z. Field  
LUNAR ROVING VEHICLE  
SYSTEMS ENGINEERING MANAGER



PREPARED BY THE BOEING COMPANY  
LRV SYSTEMS ENGINEERING  
HUNTSVILLE, ALABAMA

INDEXING DATA

| DATE    | OPR | #                | T | PGM | SUBJECT | SIGNATOR | LOC    |
|---------|-----|------------------|---|-----|---------|----------|--------|
| 4-19-71 | BOE | LS006-002-<br>2H | R | APD | *       | BOE      | 082-54 |

LS006-002-2H  
LUNAR ROVING VEHICLE  
OPERATIONS HANDBOOK

Reproduction for non-government use of the information or illustrations contained in this publication is not permitted without specific approval of the issuing service.

INSERT LATEST CHANGED PAGES  
DESTROY SUPERSEDED PAGES.

**LIST OF EFFECTIVE PAGES**

TOTAL NUMBER OF PAGES IN THIS PUBLICATION IS 342, CONSISTING OF THE FOLLOWING:

| PAGE NO.       | ISSUE           |
|----------------|-----------------|
| Title          | 19 April 1971   |
| A              | 19 April 1971   |
| i thru viii    | 19 April 1971   |
| 1-1 thru 1-78  | 19 April 1971   |
| 2-1 thru 2-50  | 19 April 1971   |
| 3-1 thru 3-12  | 19 April 1971   |
| 4-1 thru 4-11  | 19 April 1971   |
| 5-1 thru 5-4   | 19 April 1971   |
| 601 thru 6-18  | 19 April 1971   |
| 7-1 thru 7-6   | 19 April 1971   |
| 8-1 thru 8-31  | 19 April 1971   |
| Title          |                 |
| (Appendix A)   | 19 April 1971   |
| A-i thru A-v   | 19 April 1971   |
| A-1 thru A-105 | 19 April 1971   |
| Title          |                 |
| (Appendix B)   | 15 January 1971 |
| B-i            | 15 January 1971 |
| B-ii           | 15 January 1971 |
| B-1 thru B-8   | 15 January 1971 |

Mission J Basic Date 12/4/70 Change Date 4/19/71 Page A

LS006-002-2H  
LUNAR ROVING VEHICLE  
OPERATIONS HANDBOOK

---

HANDBOOK CONFIGURATION

This handbook reflects the Lunar Roving Vehicle (LRV) and Space Support Equipment (SSE) delivery review configuration as modified by incorporation of the following:

| <u>ECP</u> | <u>DESCRIPTION</u>          |
|------------|-----------------------------|
| LRV 1097   | Incorporation of Manual SSE |
| LRV 1073   | Seat Belt Modification      |
| LRV 1075   | Rear Steering Recoupling    |
| LRV 1104   | Thermal Blanket             |
| LRV 1103   | Switch Guards               |

LS006-002-2H  
LUNAR ROVING VEHICLE  
OPERATIONS HANDBOOK

---

TABLE OF CONTENTS

| SECTION | TITLE   | PAGE |
|---------|---|------|
| 1       | General Information                             | 1-1  |
| 1.0     | Introduction                                    | 1-1  |
| 1.1     | Description                                     | 1-1  |
| 1.2     | Vehicle Systems                                 | 1-1  |
| 1.3     | Mobility Subsystem                              | 1-5  |
| 1.4     | Electrical Power Subsystem                      | 1-28 |
| 1.5     | Control and Display Console                     | 1-37 |
| 1.6     | Navigation Subsystem                            | 1-42 |
| 1.7     | Crew Station                                    | 1-45 |
| 1.8     | Thermal Control                                 | 1-54 |
| 1.9     | Space Support Equipment                         | 1-64 |
| 2       | Normal Procedures                               | 2-1  |
| 2.1     | Unloading and Chassis Deployment                | 2-2  |
| 2.2     | Post Deployment Checkout and Drive to MESA      | 2-22 |
| 2.3     | Payload Loading                                 | 2-29 |
| 2.4     | Pre-Sortie Checkout and Preparation             | 2-41 |
| 2.5     | LRV Configuration for Science Stop              | 2-45 |
| 2.6     | LRV Configuration Prior to Leaving Science Stop | 2-46 |
| 2.7     | Post Sortie Checkout                            | 2-48 |
| 2.8     | Display Reading Sequence and Time Intervals     | 2-50 |
| 3       | Malfunction Procedures                          | 3-1  |
| 3.0     | Introduction                                    | 3-1  |
| 4       | Auxiliary Equipment                             | 4-1  |
| 4.0     | Introduction                                    | 4-1  |
| 4.1     | Forward Chassis Payload Provisions              | 4-1  |
| 4.2     | Center Chassis Payload Provisions               | 4-1  |
| 4.3     | Rear Chassis Payload Provisions                 | 4-6  |
| 5       | Operating Limitations                           | 5-1  |
| 5.1     | Payload Limitations                             | 5-1  |
| 5.2     | Parking Limitations                             | 5-1  |
| 5.3     | Sortie Limitations                              | 5-1  |
| 5.4     | Navigation System Limitations                   | 5-4  |



LS006-002-2H  
LUNAR ROVING VEHICLE  
OPERATIONS HANDBOOK

---

TABLE OF CONTENTS  
(Continued)

| SECTION | TITLE   | PAGE |
|---------|---|------|
| 6       | Operating Timelines   | 6-1  |
| 6.0     | Introduction  | 6-1  |
| 7       | Operating Profiles  | 7-1  |
| 7.1     | LRV Operating Profile   | 7-1  |
| 7.2     | 1G Trainer Operating Profile                                  | 7-4  |
| 8       | 1G Trainer Non-Crew Procedures                                | 8-1  |
| 8.0     | Introduction  | 8-1  |
| 8.1     | General Procedures  | 8-1  |
| 8.2     | Specific Procedures   | 8-12 |
| 8.3     | Preventive Maintenance Assembly Remove and Replace Procedures | 8-28 |

LS006-002-2H  
LUNAR ROVING VEHICLE  
OPERATIONS HANDBOOK

LIST OF ILLUSTRATIONS

| FIGURE NO. | TITLE  | PAGE |
|------------|--|------|
| 1-1        | Lunar Roving Vehicle   | 1-2  |
| 1-2        | 1G Trainer   | 1-4  |
| 1-3        | Mobility Subsystem   | 1-6  |
| 1-4        | LRV Wheel Cross-Section  | 1-7  |
| 1-5        | LRV Traction Drive Assembly                                    | 1-9  |
| 1-6        | Traction Drive Installation                                    | 1-11 |
| 1-7        | Suspension Assembly  | 1-14 |
| 1-8        | Steering Assembly  | 1-16 |
| 1-9        | Steering Control Block Diagram                                 | 1-17 |
| 1-10       | Wheel and Steering Disconnects                                 | 1-18 |
| 1-11       | Hand Controller  | 1-19 |
| 1-12       | Torque Required to Rotate Hand Controller for Throttle Control | 1-21 |
| 1-13       | Torque Required to Rotate Hand Controller for Steering Control | 1-22 |
| 1-14       | Brake Control Force Vs. Displacement                           | 1-24 |
| 1-15       | Drive Control Electronics - Block Diagram                      | 1-26 |
| 1-16       | LRV Battery Configuration                                      | 1-29 |
| 1-17       | LRV Batteries, Thermal Blanket and Dust Covers                 | 1-30 |
| 1-18       | Power Distribution System Schematic                            | 1-32 |
| 1-19       | LRV Monitor Schematic  | 1-33 |
| 1-20       | Caution and Warning System                                     | 1-34 |
| 1-21       | Auxiliary Connector Location                                   | 1-36 |
| 1-22       | Control and Display Console                                    | 1-38 |
| 1-23       | Navigation Subsystem Block Diagram                             | 1-43 |
| 1-24       | Navigation Components on LRV                                   | 1-44 |
| 1-25       | Navigation System Electrical Schematic                         | 1-45 |
| 1-26       | Vehicle Attitude Indicator                                     | 1-46 |
| 1-27       | Sun Shadow Device  | 1-47 |
| 1-28       | Crew Station Components  | 1-50 |
| 1-29       | Seat Belts   | 1-52 |
| 1-30       | Crew Station Floor Panels                                      | 1-53 |
| 1-31       | Thermal Control Provisions                                     | 1-55 |
| 1-32       | Drive Controller Electronics Thermal Control                   | 1-56 |
| 1-33       | SPU Electronics and Battery #1 Thermal Control                 | 1-57 |
| 1-34       | Battery #2 and Directional Gyro Unit Thermal Control           | 1-58 |
| 1-35       | Battery Dust Cover Closing Mechanism                           | 1-59 |
| 1-36       | Forward Chassis Insulation Blanket                             | 1-60 |
| 1-37       | Space Support Equipment  | 1-66 |
| 1-38       | LM/SSE with LRV Installed                                      | 1-67 |
| 1-39       | LRV Deployment Sequence  | 1-68 |
| 1-40       | Insulation Blanket   | 1-69 |
| 1-41       | LRV Deployment Tapes and Cables                                | 1-70 |
| 1-42       | D-Handle Release System  | 1-71 |

LS006-002-2H  
LUNAR ROVING VEHICLE  
OPERATIONS HANDBOOK

LIST OF ILLUSTRATIONS  
(CONTINUED)

| FIGURE NO. | TITLE  | PAGE |
|------------|--|------|
| 1-43       | LRV/SSE Support Structure and Release System                             | 1-72 |
| 1-44       | Braked Reel  | 1-73 |
| 1-45       | LRV Saddle and Forward Chassis Latch System                              | 1-75 |
| 1-46       | Forward and Rear Chassis Latch   | 1-76 |
| 1-47       | Wheel Lock Strut Release   | 1-77 |
| 2-1        | Support Arm Latch Mechanisms Latched Configuration                       | 2-3  |
| 2-2        | LRV Deployment Tapes and Cables  | 2-4  |
| 2-3        | LRV Deployment Envelope and Envelope for Deployment<br>Tape Operations   | 2-6  |
| 2-4        | Crewman Positioned to Deploy LRV   | 2-7  |
| 2-5        | LRV Deployment Sequence  | 2-9  |
| 2-6        | LRV Deployment Hardware & Steering Ring Location                         | 2-11 |
| 2-7        | Foot Rest Deployment   | 2-15 |
| 2-8        | Control and Display Console Deployment                                   | 2-16 |
| 2-9        | Seat and PLSS Support Deployment Sequence                                | 2-17 |
| 2-10       | Crew Position  | 2-24 |
| 2-11       | Control and Display Console  | 2-25 |
| 2-12       | LCRU/TV/LRV Cable Stowage  | 2-30 |
| 2-13       | LCRU, High Gain Antenna, TV Camera Installation                          | 2-31 |
| 2-14       | 16 mm DAC and Low Gain Antenna Installation                              | 2-34 |
| 2-15       | LCRU Low Gain Antenna Cable Installation on Lunar<br>Surface             | 2-36 |
| 2-16       | LRV Rear Payload Pallet Adapters   | 2-37 |
| 2-17       | Rear Payload Pallet Installed  | 2-39 |
| 2-18       | Buddy SLSS Installation  | 2-40 |
| 4-1        | LCRU, High Gain Antenna, TV Camera Installation                          | 4-2  |
| 4-2        | LCRU/TV/LRV Cable Stowage  | 4-3  |
| 4-3        | LCRU Low Gain Antenna Cable Installation on Lunar<br>Surface             | 4-4  |
| 4-4        | 16 mm DAC and Low Gain Antenna Installation                              | 4-5  |
| 4-5        | Under-seat Stowage Bag (Left Seat)                                       | 4-7  |
| 4-6        | Passenger Seat Stowage to Create Payload Area on<br>Center Chassis Floor | 4-8  |
| 4-7        | Buddy SLSS Installation  | 4-9  |
| 4-8        | LRV Rear Payload Pallet Adapters   | 4-10 |
| 4-9        | Rear Payload Pallet Installed  | 4-11 |
| 5-1        | Allowable C.G. Envelope for Vehicle Fully Loaded                         | 5-2  |
| 5-2        | Parking Orientation Constraints  | 5-3  |
| 6-1        | LRV Deployment Timeline  | 6-2  |
| 6-2        | Post Deployment Checkout Timeline  | 6-7  |
| 6-3        | Pre-Sortie Checkout and Preparation Timeline                             | 6-9  |
| 6-4        | Post Sortie Shutdown Timeline  | 6-11 |
| 6-5        | Navigation Update Timeline   | 6-12 |
| 6-6        | LRV Traction Drive Decoupling Timeline                                   | 6-13 |

LS006-002-2H  
LUNAR ROVING VEHICLE  
OPERATIONS HANDBOOK

LIST OF ILLUSTRATIONS  
(CONTINUED)

| FIGURE NO. | TITLE  | PAGE |
|------------|--|------|
| 6-7        | LRV Steering Decoupling Timeline   | 6-14 |
| 6-8        | LRV Rear Steering Recoupling Timeline  | 6-15 |
| 6-9        | 1G Trainer Battery Changeout Timeline  | 6-16 |
| 6-10       | 1G Trainer Traction Drive Decoupling Timeline                                      | 6-17 |
| 6-11       | 1G Trainer Steering Decoupling Timeline  | 6-18 |
| 7-1        | Nominal Operating Profile  | 7-2  |
| 7-2        | Nominal Operating Profile for 1G Trainer   | 7-5  |
| 8-1        | 1G Trainer Basic Vehicle Block Diagram   | 8-2  |
| 8-2        | 1G Trainer Vehicle Power Distribution Block Diagram                                | 8-3  |
| 8-3        | 1G Trainer Vehicle Front Traction Drive Electrical<br>Signal Routing Block Diagram | 8-4  |
| 8-4        | 1G Trainer Vehicle Rear Traction Drive Electrical<br>Signal Routing Block Diagram  | 8-5  |
| 8-5        | 1G Trainer Vehicle Front Steering Electrical<br>Signal Routing Block Diagram       | 8-6  |
| 8-6        | 1G Trainer Vehicle Rear Steering Electrical Routing<br>Block Diagram               | 8-7  |
| 8-7        | 1G Trainer Vehicle Odometer Electrical Signal<br>Routing Block Diagram             | 8-8  |
| 8-8        | 1G Trainer Temperature Diagnostics Electrical Signal<br>Routing Block Diagram      | 8-9  |
| 8-9        | 1G Trainer Wheel Decoupling  | 8-17 |
| 8-10       | 1G Trainer Brake Linkage   | 8-19 |
| 8-11       | 1G Trainer Steering Arm Clamping   | 8-22 |
| 8-12       | 1G Trainer Battery Installation  | 8-24 |
| 8-13       | 1G Trainer Battery Charging Circuit  | 8-26 |

LS006-002-2H  
LUNAR ROVING VEHICLE  
OPERATIONS HANDBOOK

---

LIST OF TABLES

| TABLE NO. | TITLE  | PAGE |
|-----------|--|------|
| 1-1       | Control and Display Console Controls         | 1-39 |
| 1-2       | 1G Trainer Thermal Control Device Set Points | 1-62 |
| 3-1       | Malfunction Procedures                       | 3-2  |
| 3-2       | Malfunction Logic Flow Diagrams              | 3-3  |
| 8-1       | 1G Trainer Steering Operation Data           | 8-15 |

LS006-002-2H  
LUNAR ROVING VEHICLE  
OPERATIONS HANDBOOK

---

LRV FLIGHT UNIT PARTIAL DRAWING LIST  
(FOR REFERENCE ONLY)

| <u>DESCRIPTION</u>                      | <u>DRAWING NUMBER</u> |
|---|-----------------------|
| Flight Vehicle Assembly                 | 209-35006             |
| Chassis Assembly                        | 209-30006             |
| Tripod                                  | 209-30406             |
| Fender                                  | 209-31625             |
| Crew Station Installation               | 209-31006             |
| Suspension and Wheel Installation       | 209-35206             |
| Steering Installation                   | 209-35306             |
| Electrical and Battery Installation     | 209-34006             |
| Electrical Cabling Installation         | 209-35106             |
| Display and Control Console Assembly    | 209-22200             |
| Gyro and SPU Installation               | 209-34306             |
| Vehicle Attitude Indicator Installation | 209-60050             |
| Thermal Insulation Installation         | 209-34406             |
| Gyro Thermal Strap                      | 209-70019             |
| SPU Thermal Control Unit                | 209-70400             |
| DCE Assembly                            | 7553139*              |
| Hand Controller Assembly                | 7553447*              |
| Traction Drive Assembly                 | 7553102*              |

\*Denotes AC/Delco Electronics Drawings, All Others are Boeing

SECTION I  
GENERAL INFORMATION

1.0 INTRODUCTION

This section contains general information pertaining to the flight operational Lunar Roving Vehicle (LRV). Where applicable, the 1G Trainer differences are noted.

1.1 DESCRIPTION

The LRV system on the lunar surface consists of the LRV, the structure for securing the LRV to the LM stowage bay and the mechanism for deploying the LRV from the LM onto the lunar surface.

1.2 VEHICLE SYSTEMS

The LRV (figure 1-1) is a four-wheeled, self-propelled, manually controlled vehicle to be used for transporting crewmen and equipment on the lunar surface. The vehicle has accommodations for two crewmen and the stowed auxiliary equipment designed for the particular mission.

Control of the LRV during traverses is effected from either of the two crewmen positions by operating the hand controller located between the two crewmen positions. Selection of power supplied to each load, monitoring of key parameters, and operation of the navigation system is effected from the control and display console, which is located for operation by either crewman.

\*\*\*1G Trainer Notes\*\*\*

1. 1G Trainer vehicle systems are shown on figure 1-2.
2. Electrical block diagrams for the 1G Trainer are provided in Section 8.0.

LS006-002-2H  
LUNAR ROVING VEHICLE  
OPERATIONS HANDBOOK

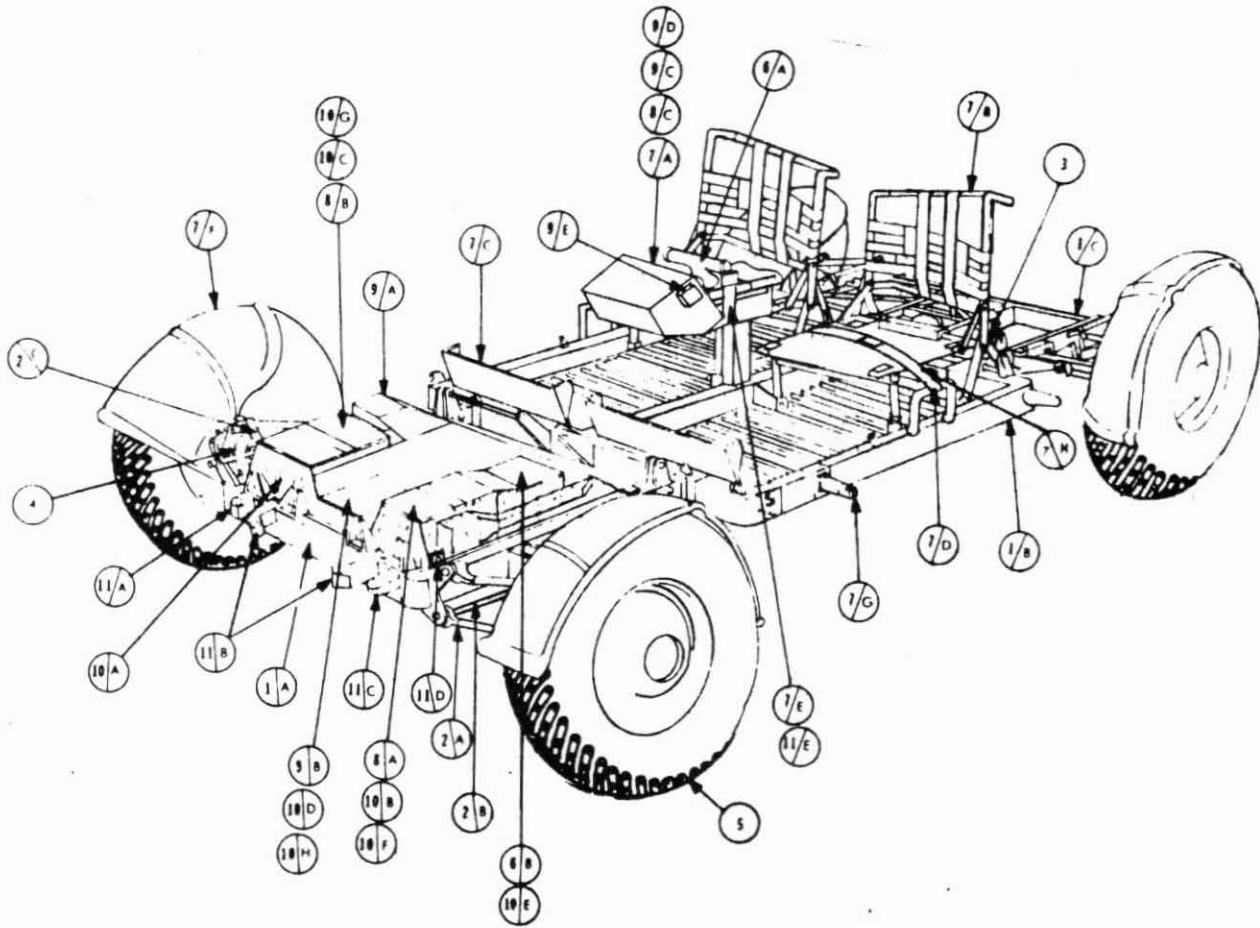

① CHASSIS

- A. FORWARD CHASSIS
- B. CENTER CHASSIS
- C. AFT CHASSIS

② SUSPENSION SYSTEM

- A. SUSPENSION ARMS (UPPER AND LOWER)
- B. TORSION BARS (UPPER AND LOWER)
- C. DAMPLER

③ STEERING SYSTEM (FORWARD AND AFT)

④ TRACTION DRIVE

⑤ WHEEL

⑥ DRIVE CONTROL

- A. HAND CONTROLLER
- B. DRIVE CONTROL ELECTRONICS (DCE)

⑦ CREW STATION

- A. CONTROL AND DISPLAY CONSOLE
- B. SEAT
- C. FOOTREST
- D. OUTBOARD HANDHOLD
- E. INBOARD HANDHOLD
- F. FENDER
- G. TIEHOLD
- H. SEAT BOLT

⑧ POWER SYSTEM

- A. BATTERY #1
- B. BATTERY #2
- C. INSTRUMENTATION

⑨ NAVIGATION

- A. DIRECTIONAL GYRO UNIT (DGU)
- B. SIGNAL PROCESSING UNIT (SPU)
- C. INTEGRATED POSITION INDICATOR (IPI)
- D. SUN SHADOW DEVICE
- E. VEHICLE ATTITUDE INDICATOR

⑩ THERMAL CONTROL

- A. INSULATION BLANKET
- B. BATTERY NO. 1 DUST COVER
- C. BATTERY NO. 2 DUST COVER
- D. SPU DUST COVER
- E. DCE THERMAL CONTROL UNIT
- F. BATTERY NO. 1 RADIATOR
- G. BATTERY NO. 2 RADIATOR
- H. SPU THERMAL CONTROL UNIT

⑪ PAYLOAD INTERFACE

- A. TV CAMERA RECEPTACLE
- B. LCRU RECEPTACLE
- C. HIGH GAIN ANTENNA RECEPTACLE
- D. AUXILIARY CONNECTOR
- E. LOW GAIN ANTENNA RECEPTACLE

FIGURE 1-1 LRV WITHOUT STOWED PAYLOAD (SHEET 1 OF 2)



AXIS REFERENCE

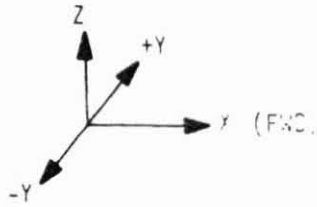

(DEPLOYED, EMPTY)

WEIGHT = 462 LB\*

C.G. LOCATION:

X = 52.8  
Y = -0.3  
Z = 103.1

\*INCLUDES BATTERIES  
& PAYLOAD SUPPORTS,  
EXCLUDES SSE.

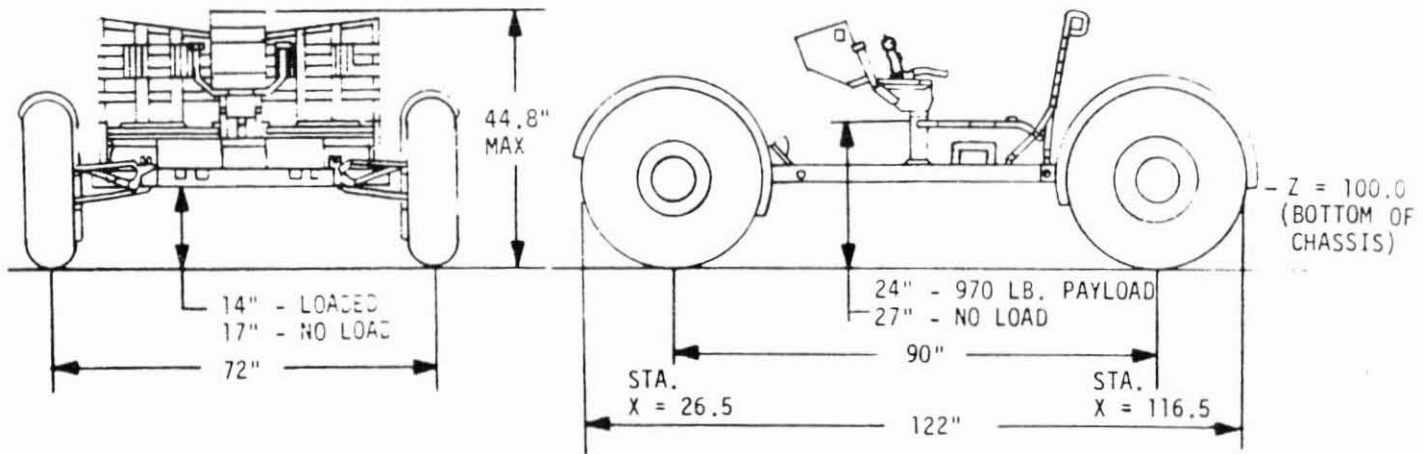
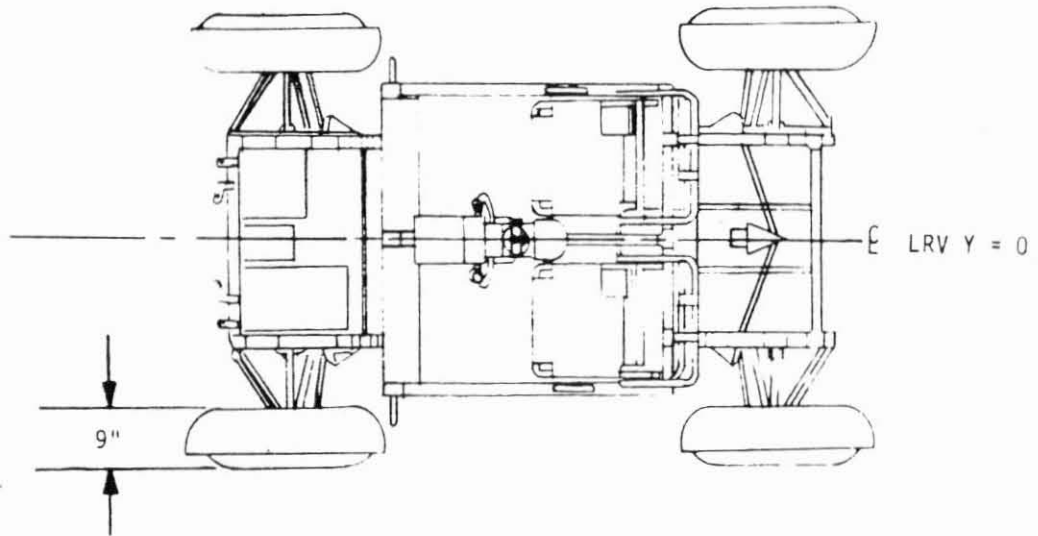

FIGURE 1-1 LRV COMPONENTS AND DIMENSIONS (SHEET 2 OF 2)

LS006-002-2H  
LUNAR ROVING VEHICLE  
OPERATIONS HANDBOOK

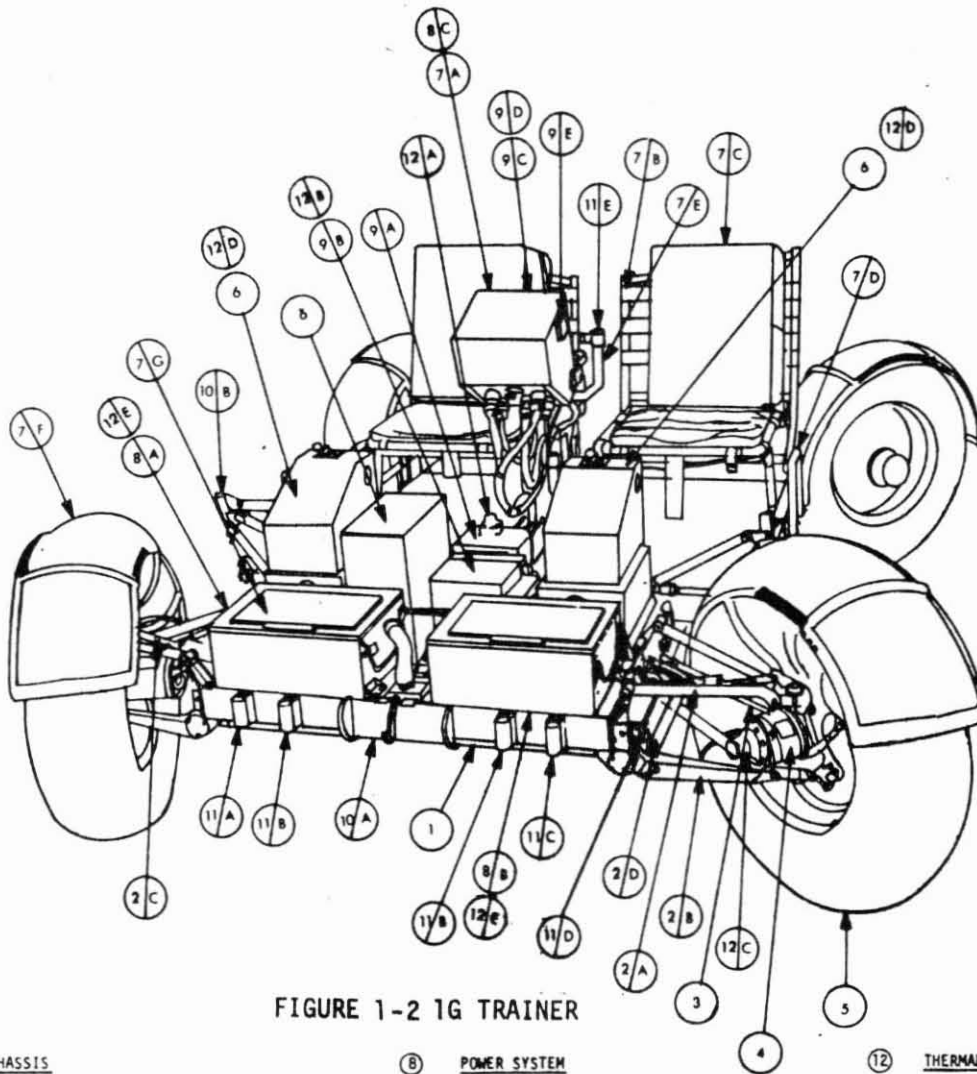

FIGURE 1-2 1G TRAINER

- |  |  |   |
|--|--|---|
| <p>① <u>CHASSIS</u></p> <p>② <u>SUSPENSION SYSTEM</u></p> <p>A. UPPER ARM<br/>B. LOWER ARM<br/>C. DAMPER<br/>D. TORSION BAR</p> <p>③ <u>STEERING SYSTEM (FORWARD AND REAR)</u></p> <p>④ <u>TRACTION DRIVE</u></p> <p>⑤ <u>WHEEL</u></p> <p>⑥ <u>DRIVE CONTROLLERS</u></p> <p>⑦ <u>CREW STATION</u></p> <p>A. CONTROL AND DISPLAY CONSOLE<br/>B. SEAT<br/>C. REMOVABLE PAD (FOR UNSUITED CREW USE)<br/>D. OUTBOARD HANDHOLD<br/>E. INBOARD HANDHOLD<br/>F. FENDER<br/>G. SIMULATED DUST COVER</p> | <p>⑧ <u>POWER SYSTEM</u></p> <p>A. BATTERY #1<br/>B. BATTERY #2<br/>C. INSTRUMENTATION</p> <p>⑨ <u>NAVIGATION</u></p> <p>A. DIRECTIONAL GYRO UNIT (DGU)<br/>B. SIGNAL PROCESSING UNIT (SPU)<br/>C. INTEGRATED POSITION INDICATOR (IPI)<br/>D. SUN SHADOW DEVICE<br/>E. ATTITUDE INDICATOR</p> <p>⑩ <u>DEPLOYMENT SIMULATION</u></p> <p>A. FORWARD CHASSIS SADDLE SIMULATOR<br/>B. TRIPOD SIMULATORS (BOTH SIDES)</p> <p>⑪ <u>PAYLOAD INTERFACE</u></p> <p>A. TV CAMERA RECEPTACLE<br/>B. LCRU RECEPTACLE<br/>C. HIGH GAIN ANTENNA RECEPTACLE<br/>D. AUXILIARY CONNECTOR<br/>E. LOW GAIN ANTENNA RECEPTACLE</p> | <p>⑫ <u>THERMAL CONTROL</u></p> <p>A. DGU HEAT EXCHANGER<br/>B. SPU HEAT EXCHANGER<br/>C. TRACTION DRIVE BLOWERS (4)<br/>D. DCE BLOWERS<br/>E. BATTERY BLOWER</p> |
|--|--|---|

### 1.3 MOBILITY SUBSYSTEM

The mobility subsystem (figure 1-3) consists of the chassis and equipment and controls necessary to propel, suspend, brake and steer the LRV.

#### 1.3.1 Wheel

Each wheel (figure 1-4, Sh 1) includes an open wire mesh tire with chevron tread covering 50 percent of the surface contact area. The tire inner frame prevents excessive deflection of the outer wire mesh frame under high impact load conditions.

Each wheel has a decoupling mechanism (figure 1-5) and can be decoupled from the traction drive by operating the two decoupling mechanisms (figure 1-10) which allows the wheel to "free-wheel" about a bearing independent of the drive train. This decoupling mechanism can also be used to re-engage the wheel with the traction drive. Decoupling disables the brake on the affected wheel.

#### \*\*\*1G Trainer Notes\*\*\*

1. The 1G Trainer tires for primary use are pneumatic automobile tires (figure 1-4, Sh 2) Special wire mesh wheels are also available for use with the 1G Trainer.
2. The 1G Trainer has simulated wheel decoupling mechanisms to duplicate the LRV-to-Crew interface. Operation of this simulated mechanism, however, will not effect actual decoupling. Procedures for 1G Trainer wheel decoupling are shown in Section 8. Wheel decoupling on the 1G Trainer does not disable the brake on the affected wheels.

#### 1.3.2 Traction Drive

Each wheel is provided with a separate traction drive (figure 1-5, Sh 1) consisting of a harmonic drive reduction unit, drive motor and brake assembly. Each traction drive is hermetically sealed to maintain a 7.5 PSIA internal pressure for improved brush lubrication. Each traction drive also contains an odometer pickup which transmits a pulse to the navigation system signal processing unit at the rate of nine pulses per wheel revolution.

LS006-002-2H  
LUNAR ROVING VEHICLE  
OPERATIONS HANDBOOK

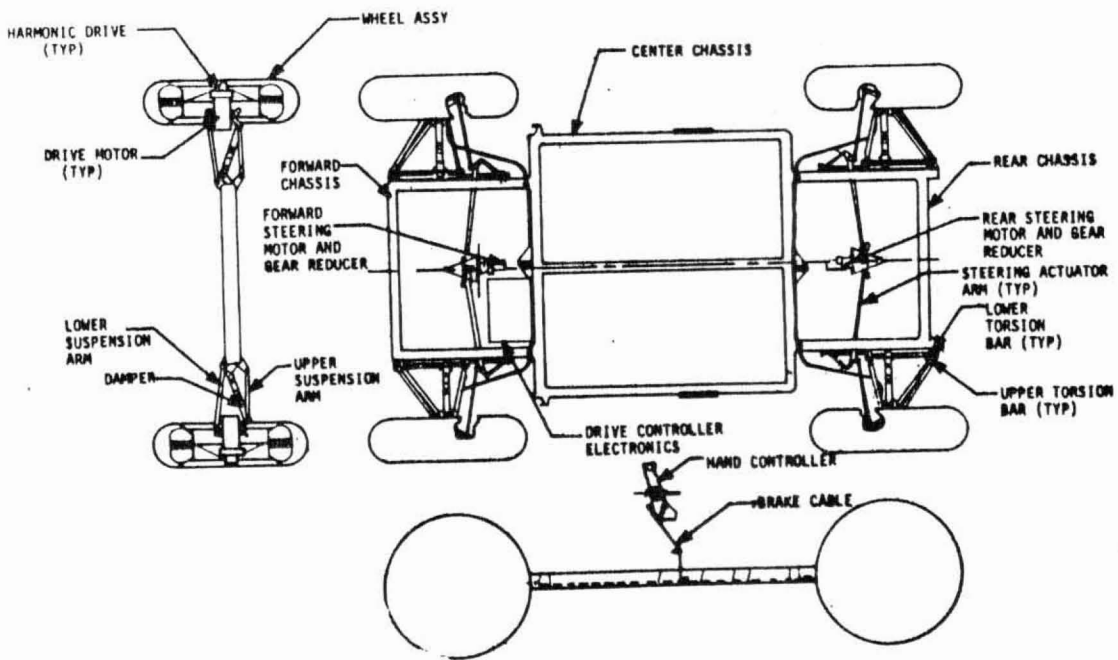
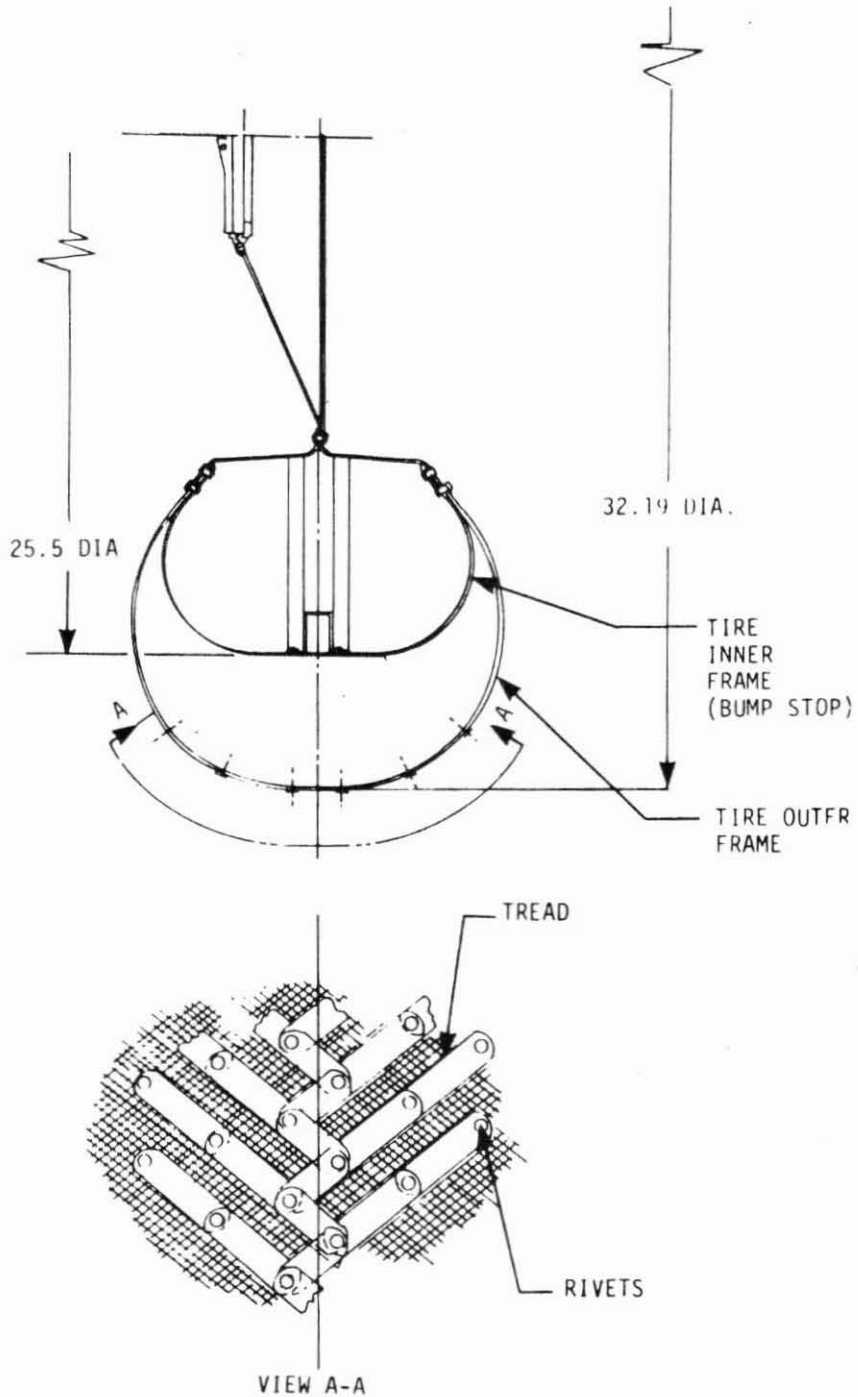

FIGURE 1-3 MOBILITY SUBSYSTEM

LS006-002-2H  
LUNAR ROVING VEHICLE  
OPERATIONS HANDBOOK



VIEW A-A  
FIGURE 1-4 LRV WHEEL CROSS-SECTION (SHEET 1 OF 2)

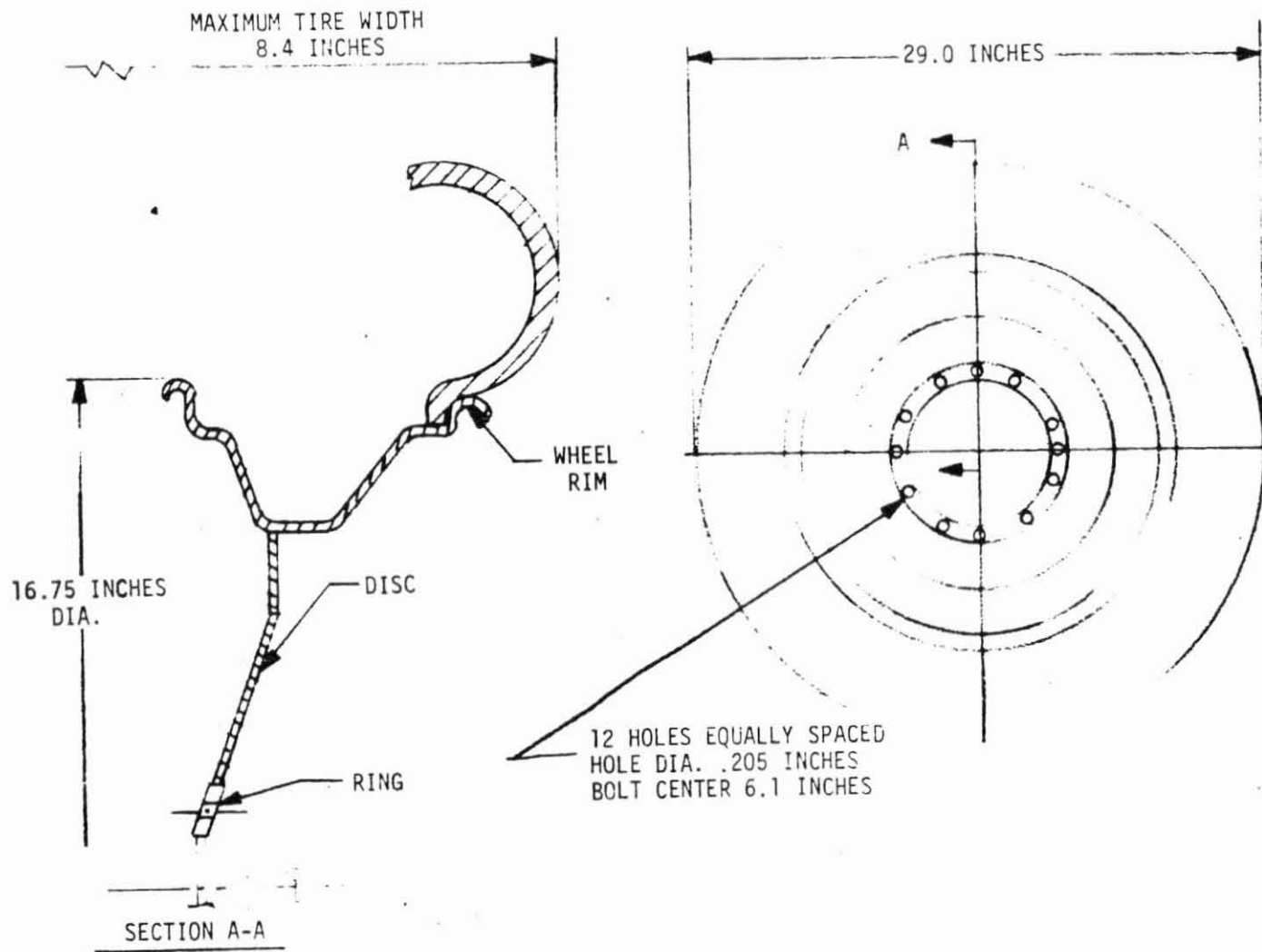

FIGURE 1-4 1G TRAINER WHEEL AND PNEUMATIC TIRE (SHEET 2 OF 2)

LS006-002-2H  
LUNAR ROVING VEHICLE  
OPERATIONS HANDBOOK

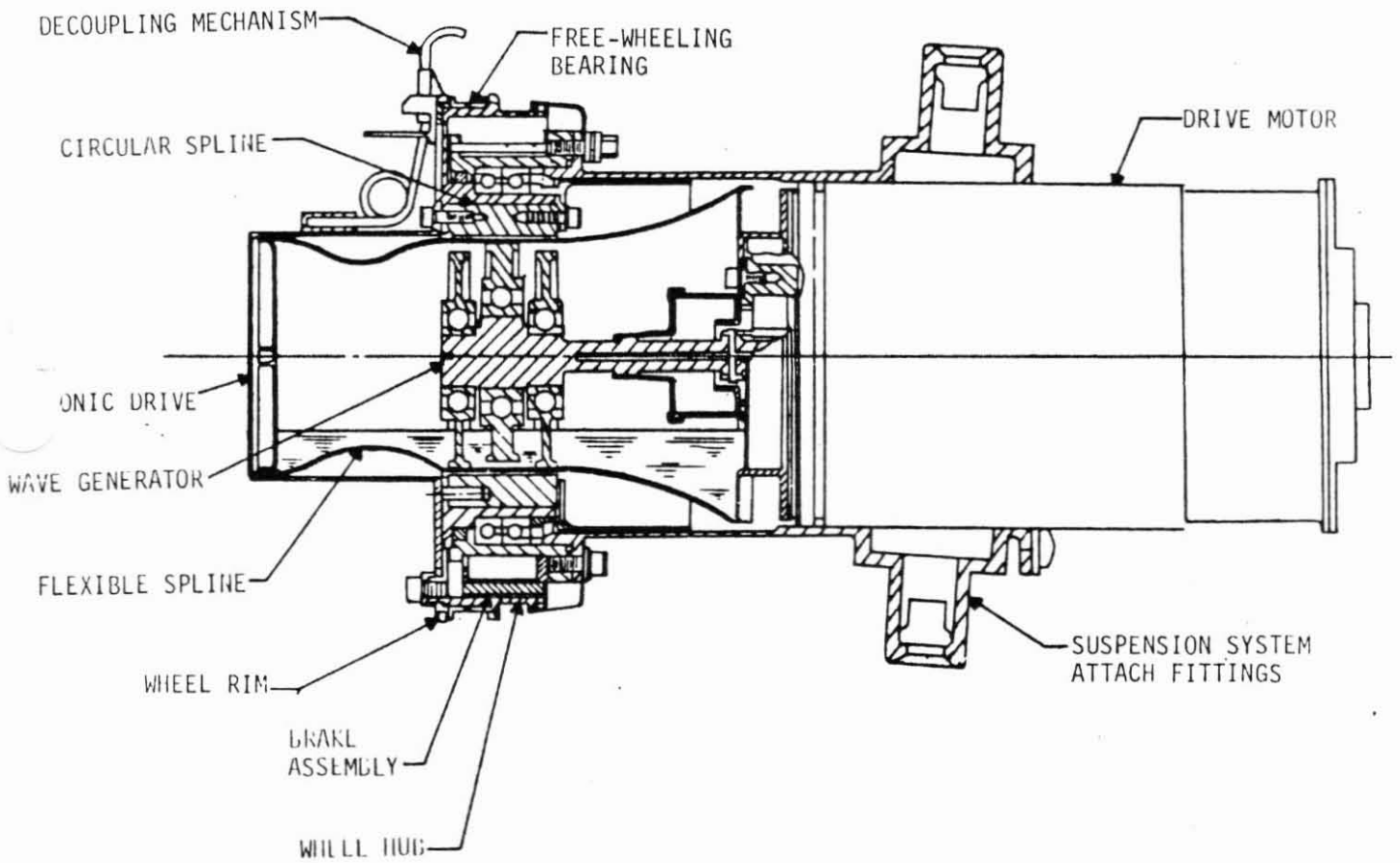

FIGURE 1-5. LRV TRACTION DRIVE ASSEMBLY (SHEET 1 OF 2)

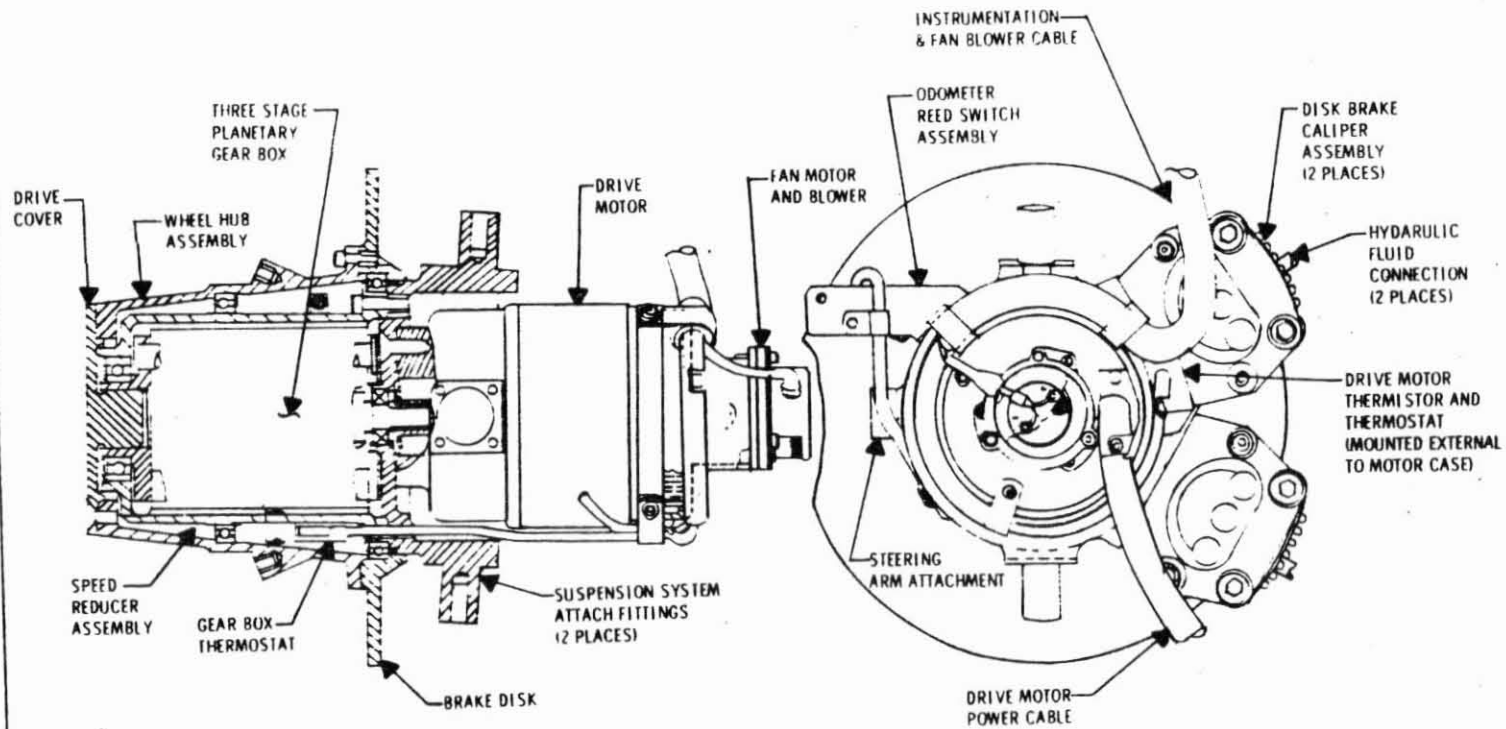

FIGURE 1-5 1G TRAINER TRACTION DRIVE ASSEMBLY (SHEET 2 OF 2)



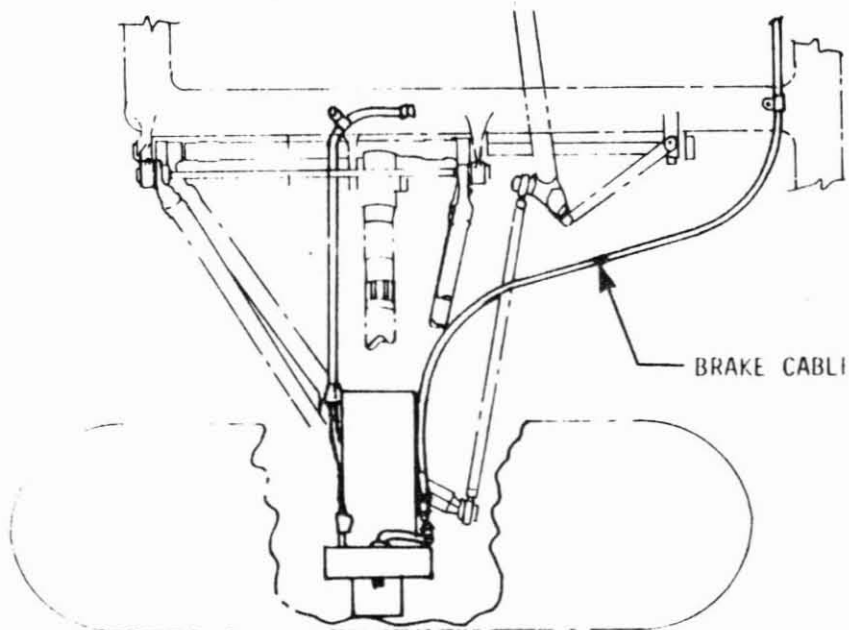
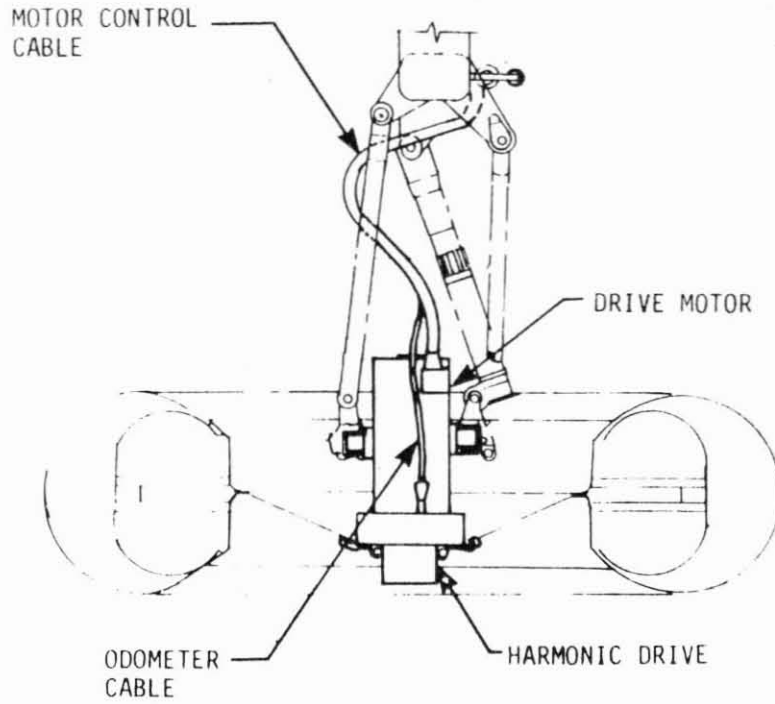

FIGURE 1-6. TRACTION DRIVE INSTALLATION

\*\*\*1G Trainer Notes\*\*\*

1. The traction drive for the 1G Trainer has a 3-stage planetary gear box in lieu of the harmonic drive, (figure 1-5, Sh 2).
2. 1G Trainer traction drives are not hermetically sealed.

1.3.2.1 Harmonic Drive

The four harmonic drive reduction units transmit torque to each wheel. Input torque to the four harmonic drives is supplied by the four electric drive motors. The harmonic drives reduce the motor speed at the rate of 80:1 and allow continuous application of torque to the wheels at all speeds without requiring gear shifting. Speed/torque/efficiency characteristics of the harmonic drive units are shown in Appendix A.

1.3.2.2 Drive Motor

The drive motors are direct current series, brush type motors which operate from a nominal input voltage of 36 VDC. Speed control for the motors is furnished by pulse width modulation from the drive controller electronic package. Performance characteristics for the drive motors are shown in Appendix A. Suspension system attach fittings on each motor also form the king-pin for the LRV steering system. Each motor is instrumented for thermal monitoring. An analog temperature measurement from a thermistor at the stator field is displayed on the control and display panel. In addition, each motor contains a thermal switch which closes on increasing temperature at 400°F and provides an input signal to the caution and warning system to actuate the warning flag.

\*\*\*1G Trainer Notes\*\*\*

1. The 1G Trainer drive motors operate from a nominal input voltage of 34 VDC.
2. The 1G Trainer gear box thermal switch will actuate the warning flag when a gear box temperature reaches 200°F. The indicated temperature, however, will be 450°F to 500°F upon actuation, since the readouts are biased.
3. The 1G Trainer motor temperature switch is set to actuate the flag when the motor external case temperature reaches 225°F. This temperature at the case would correspond to a rotor temperature of about 450°F.

### 1.3.2.3 Brakes

Each traction drive is equipped with a mechanical brake actuated by a cable connected to a linkage in the hand controller. Stopping distance capability using these brakes is shown in Appendix A.

Braking is accomplished by moving the hand controller rearward. This operation de-energizes the drive motor and, through a linkage and cable, forces brake shoes against a brake drum which stops the rotation of the wheel hub about the harmonic drive.

#### \*\*\*1G Trainer Note\*\*\*

The 1G Trainer brakes are hydraulically actuated disc brakes. Brakes are actuated by the hand controller in the same manner as the LRV mechanical brakes.

### 1.3.3 Suspension

The chassis (figure 1-7) is suspended from each wheel by a pair of parallel triangular arms connected between the LRV chassis and each traction drive. Loads are transmitted to the chassis through each suspension arm to a separate torsion bar for each arm. Wheel vertical travel and rate of travel is limited by a linear damper connected between the chassis and each traction drive. The deflection of the suspension system and tires combine to allow 14 inches of chassis ground clearance when the LRV is fully loaded and 17 inches when unloaded.

Damping energy heats the fluid in the damper. The heat is conducted from the fluid to the damper walls for dissipation.

The suspension systems can be rotated approximately 135 degrees to allow folding and LRV stowage in the LM.

#### \*\*\*1G Trainer Notes\*\*\*

1. 1G Trainer suspension is not designed to allow folding for LM stowage.
2. 1G Trainer suspension system contains only a lower torsion bar on each wheel.

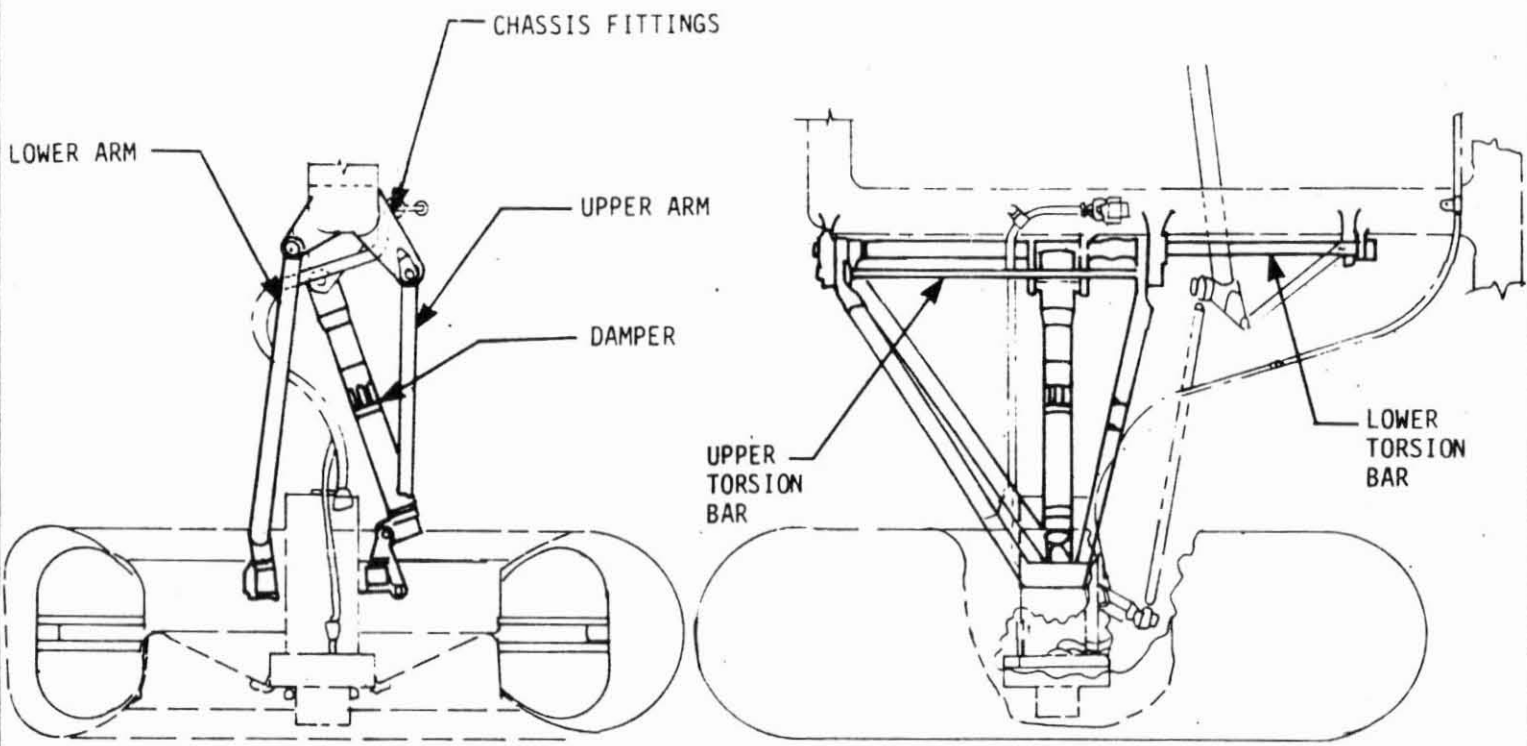

FIGURE 1-7. SUSPENSION ASSEMBLY

#### 1.3.4 Steering

LRV steering (figure 1-8) is accomplished by Ackermann-geometry steering of both the front and rear wheels allowing a wall-to-wall turning radius of 122 inches. Steering is controlled by moving the hand controller left or right from the nominal position. This operation energizes separate electric motors for the front and rear wheels, and through a servo system, provides a steering angle proportional to the position of the hand controller. (The steering control block diagram is shown in figure 1-9).

Each steering motor is connected to a speed reducer which drives a spur gear sector which, in turn, actuates the steering linkage to accomplish the change in steering angle. Maximum travel position of the sector provides an outer wheel angle of 22 degrees and inner wheel angle of 50 degrees. The steering rate is such that lock-to-lock steering can be accomplished in 5.5 (+ 0.5) seconds.

The front and rear steering assemblies are mechanically independent of each other. In the event of motor/speed reducer failure, the steering linkage can be disengaged from the sector, the wheels can be centered and locked, and operations can continue using the remaining active steering assembly. Steering disconnect points are shown in figure 1-10. Forward steering reconnection cannot be accomplished by a crewman. The rear steering reconnection can be accomplished by a crewman as described in Section 2.9.

#### \*\*\*1G Trainer Notes\*\*\*

1. The 1G Trainer steering utilizes continuously operating steering motor. Hand controller movement energizes the appropriate (one of two) counter rotating magnetic particle clutches, thereby engaging the load and effecting steering. A magnetic brake is actuated when the clutches are not engaged.
2. The 1G Trainer has simulated steering decoupling mechanisms to duplicate the LRV-to-Crew interface. Operation of this simulated mechanism, however, will not effect actual decoupling. Procedures for 1G Trainer steering decoupling are shown in Section 8.0.

#### 1.3.5 Hand Controller

The hand controller (figure 1-11) provides the steering, speed, and braking commands to the drive controller electronics. The drive controller electronics then processes these hand controller commands to the appropriate drive motors and steering motors to effect the desired control function. The hand controller is also used as the mechanical brake lever.

LS006-002-2H  
LUNAR ROVING VEHICLE  
OPERATIONS HANDBOOK

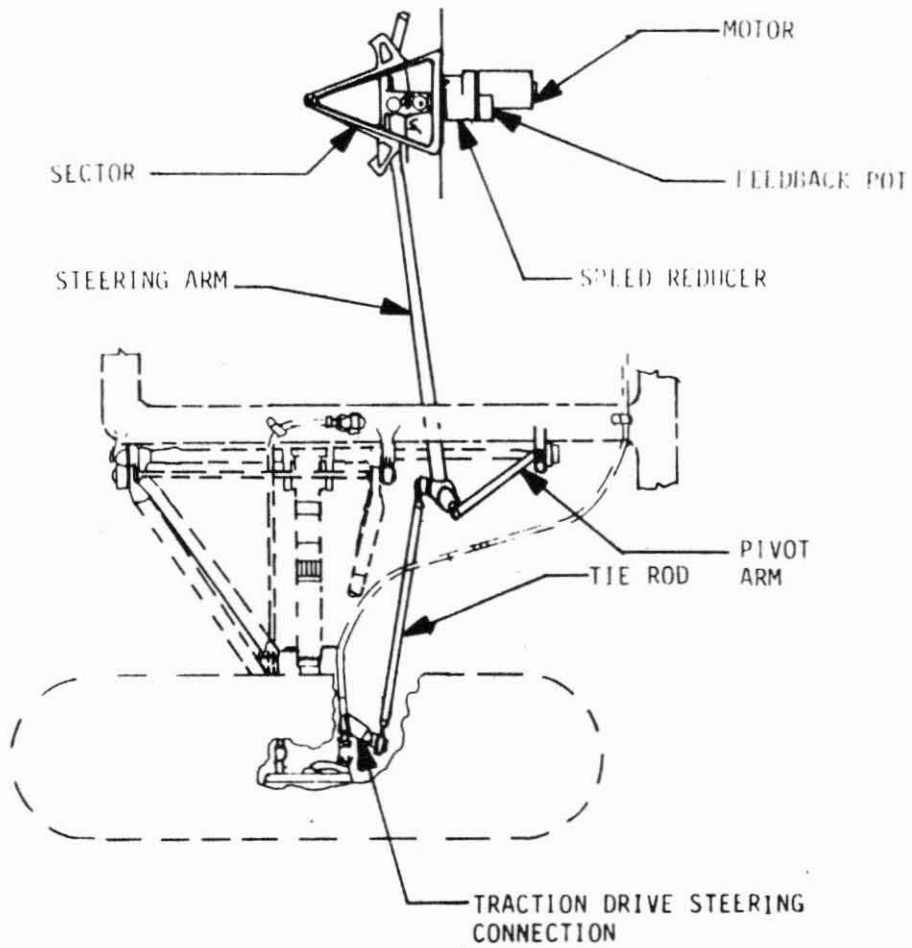

FIGURE 1-8. STEERING ASSEMBLY

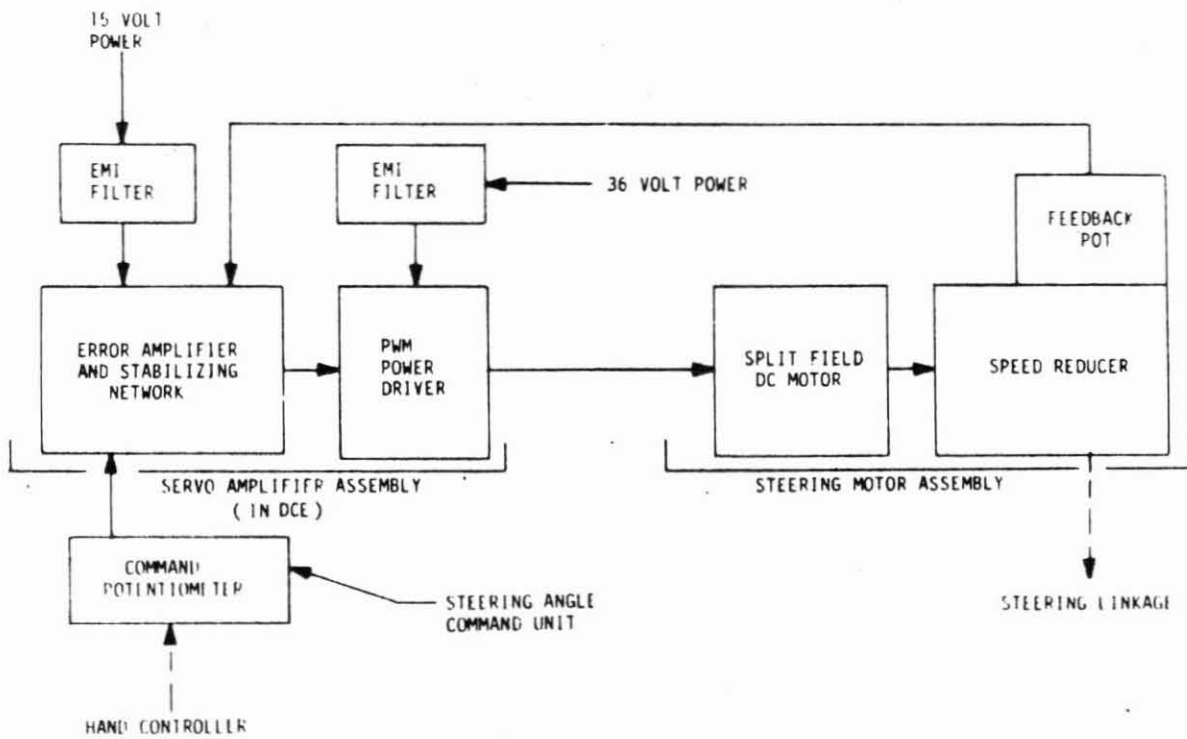
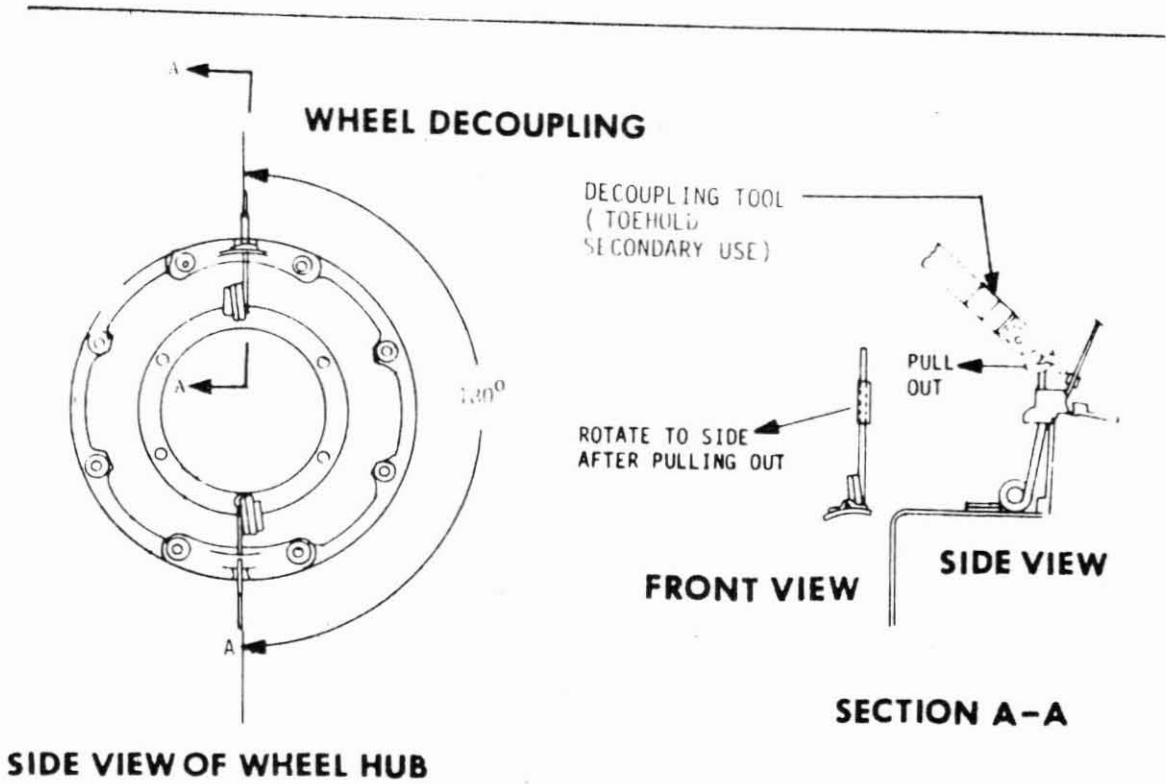

FIGURE 1-9. STEERING CONTROL BLOCK DIAGRAM



STEERING MOTOR DECOUPLING

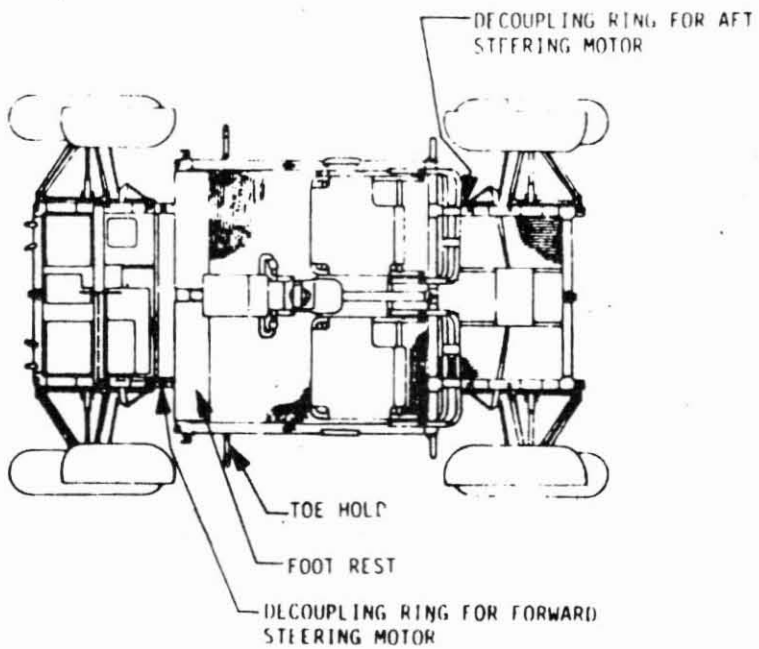

FIGURE 1-10. WHEEL AND STEERING DISCONNECTS



HAND CONTROLLER OPERATION:

- T-HANDLE PIVOT FORWARD - INCREASED DEFLECTION FROM NEUTRAL INCREASES FORWARD SPEED.
- T-HANDLE PIVOT REARWARD - INCREASED DEFLECTION FROM NEUTRAL INCREASES REVERSE SPEED.
- T-HANDLE PIVOT LEFT - INCREASED DEFLECTION FROM NEUTRAL INCREASES LEFT STEERING ANGLE.
- T-HANDLE PIVOT RIGHT - INCREASED DEFLECTION FROM NEUTRAL INCREASES RIGHT STEERING ANGLE.
- T-HANDLE DISPLACED REARWARD - REARWARD MOVEMENT INCREASES BRAKING FORCE. FULL 3 INCH REARWARD APPLIES PARKING BRAKE. MOVING INTO BRAKE POSITION DISABLES THROTTLE CONTROL AT 15° MOVEMENT REARWARD.

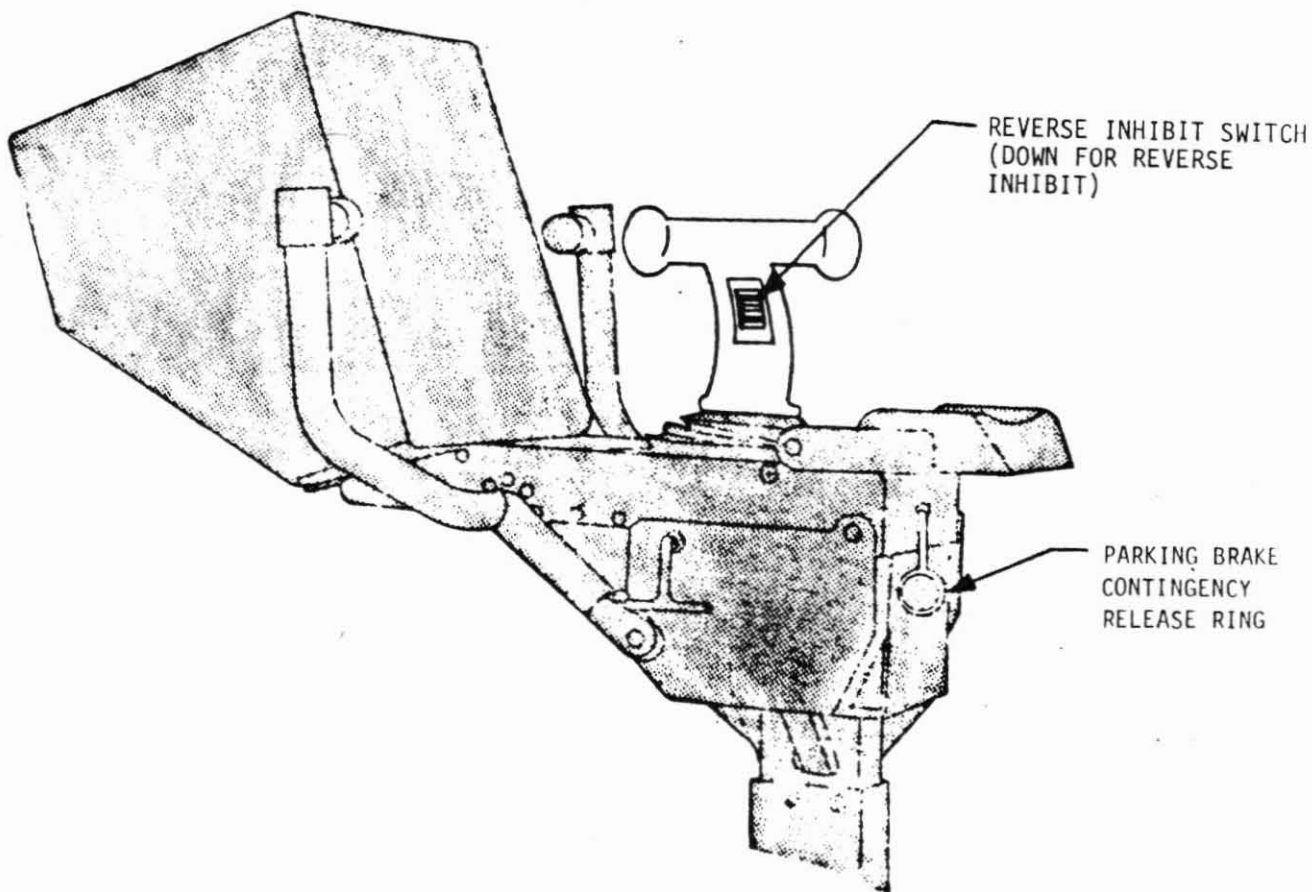

FIGURE 1-11. HAND CONTROLLER

LS006-002-2H  
LUNAR ROVING VEHICLE  
OPERATIONS HANDBOOK

---

### 1.3.5.1 Speed Control

Forward movement of the hand controller about the T-handle throttle pivot axis proportionately increases forward speed. A neutral dead band exists for about the first 1.5 degrees of forward motion. A constant torque of about 6 inch-pounds is required to move the hand controller beyond the limit of the dead band (figure 1-12). The nine degree position corresponds to a pulse duty cycle of approximately 50 percent, at each drive motor, i.e., the motors are at 50 percent of maximum speed condition. The maximum power setting is achieved by pivoting the hand controller to the hard stop (maximum) position at approximately 14 degrees. To decelerate, the hand controller is pivoted rearward. The torques required are shown in figure 1-12. To place the vehicle in neutral, the hand controller is pivoted rearward to the zero ( $\pm 1/2$ ) degree position.

With the reverse inhibit switch in the down position, the hand controller can be pivoted forward only, thereby preventing inadvertently placing the vehicle in reverse.

To operate the vehicle in reverse, the reverse inhibit switch is placed in the up position and the hand controller pivoted rearward about the throttle pivot point. Torque vs. displacement characteristics for reverse are identical to forward speed operation as shown by figure 1-12.

The vehicle must be brought to a full stop before a direction change is commanded. Direction change is automatically inhibited at vehicle speeds greater than 1 KPH.

The hand controller will remain in the selected forward or reverse speed position in the crewmen "hands off" condition.

### 1.3.5.2 Steering Control

Pivoting the hand controller left or right about the roll pivot point proportionally changes the wheel steering angle. The steering control, like the throttle control, has a 1/2 degree neutral dead band on either side of zero. (See figure 1-13). A torque of 7 in-lbs. is required to roll the hand controller beyond the neutral position to begin steering angle change. Torque required for increasing the displacement angle about the roll pivot point increases linearly until a displacement of approximately 9 degrees is reached. At the 9 degree position, a soft stop is encountered which requires a step-function torque increase of 5 in-lbs. to pivot the hand controller further outboard for increasing the steering angle. After passing the soft stop

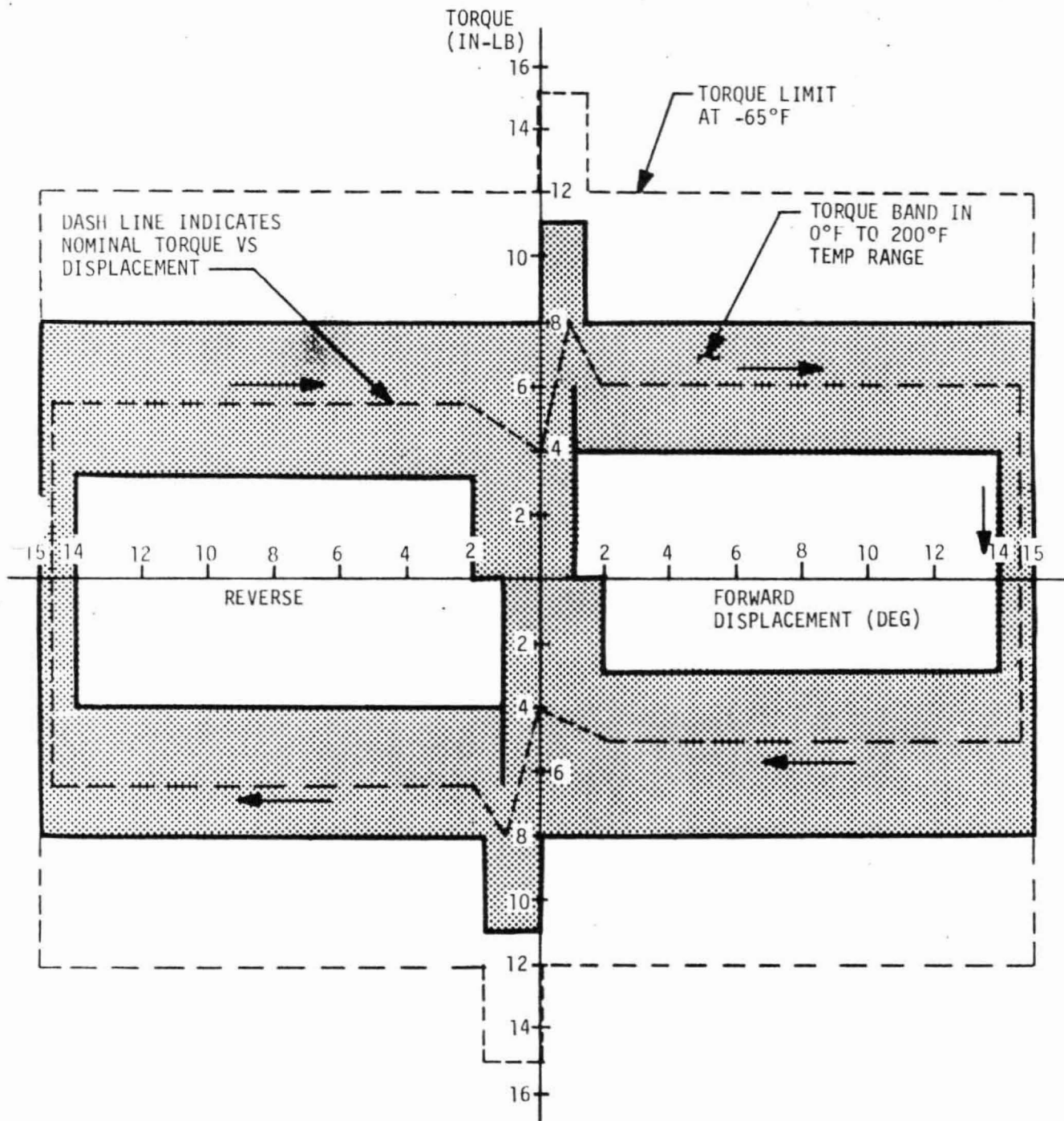

FIGURE 1-12 TORQUE REQUIRED TO ROTATE HAND CONTROLLER FOR THROTTLE CONTROL

LS006-002-2H  
 LUNAR ROVING VEHICLE  
 OPERATIONS HANDBOOK

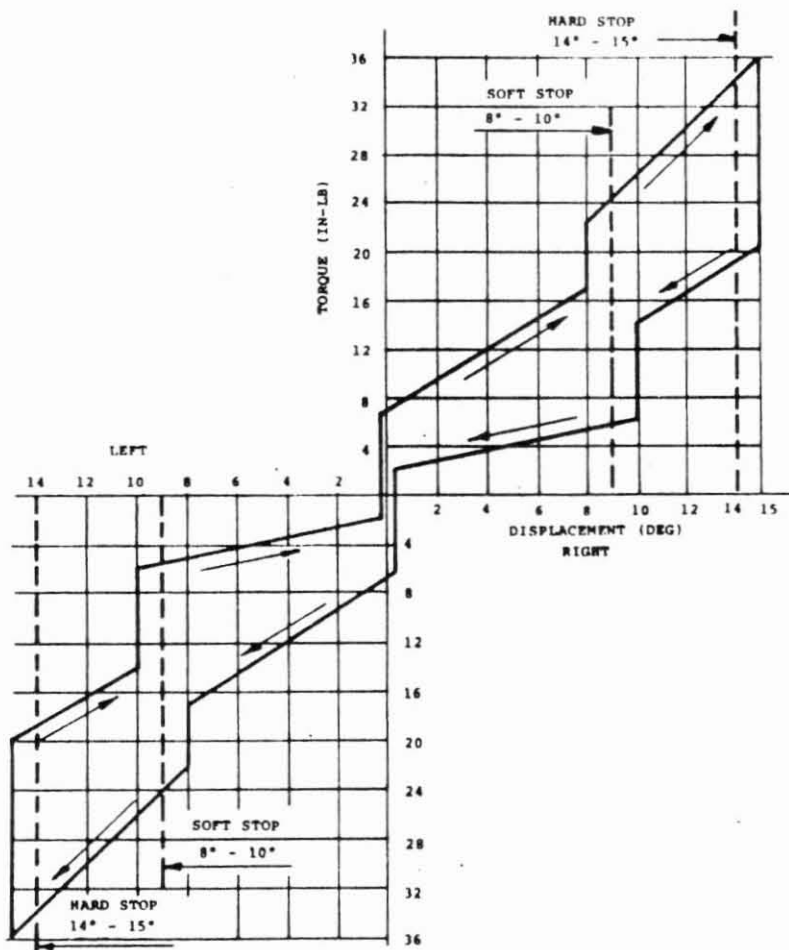

FIGURE 1-13 TORQUE REQUIRED TO ROTATE HAND CONTROLLER FOR STEERING CONTROL

1.3.5.2 (Continued)

position, the torque required to pivot the hand controller further outboard increases linearally with displacement until the hand controller hard stop limit is reached at the 14 degree outboard hand controller position.

The hand controller is spring loaded to return to the neutral steering position when released.

1.3.5.3 Braking Control

Braking is initiated with the LRV in either forward or reverse by pivoting the hand controller rearward about the brake pivot point. The force required to move the hand controller rearward to increase braking is shown in Figure 1-14. Forward and reverse power is disabled when the brake is displaced 15 degrees.

A three inch rearward displacement of the hand controller engages and locks the parking brake. To disengage the parking brake, the hand controller is placed in the steer left position. A contingency release (figure 1-11) is provided should the brake fail to release when moved to the steer left position. Contingency brake release is effected by moving the brake to full rearward displacement, pulling the release ring, allowing the brake to release and then releasing the ring.

\*\*\*1G Trainer Notes\*\*\*

1. The 1G Trainer hand controller operation (speed, steering and brake) is identical to the LRV hand controller operation, with the exception: If the hand controller is in full throttle position when full brakes are applied, drive power will not be automatically cut-out. This condition (true for both forward and reverse operation) resulted as a consequence of by-passing the DCE logic to eliminate voltage drop and thereby increase trainer top speed.
2. The 1G Trainer brake cables can be adjusted to provide simulated lunar surface stopping characteristics.

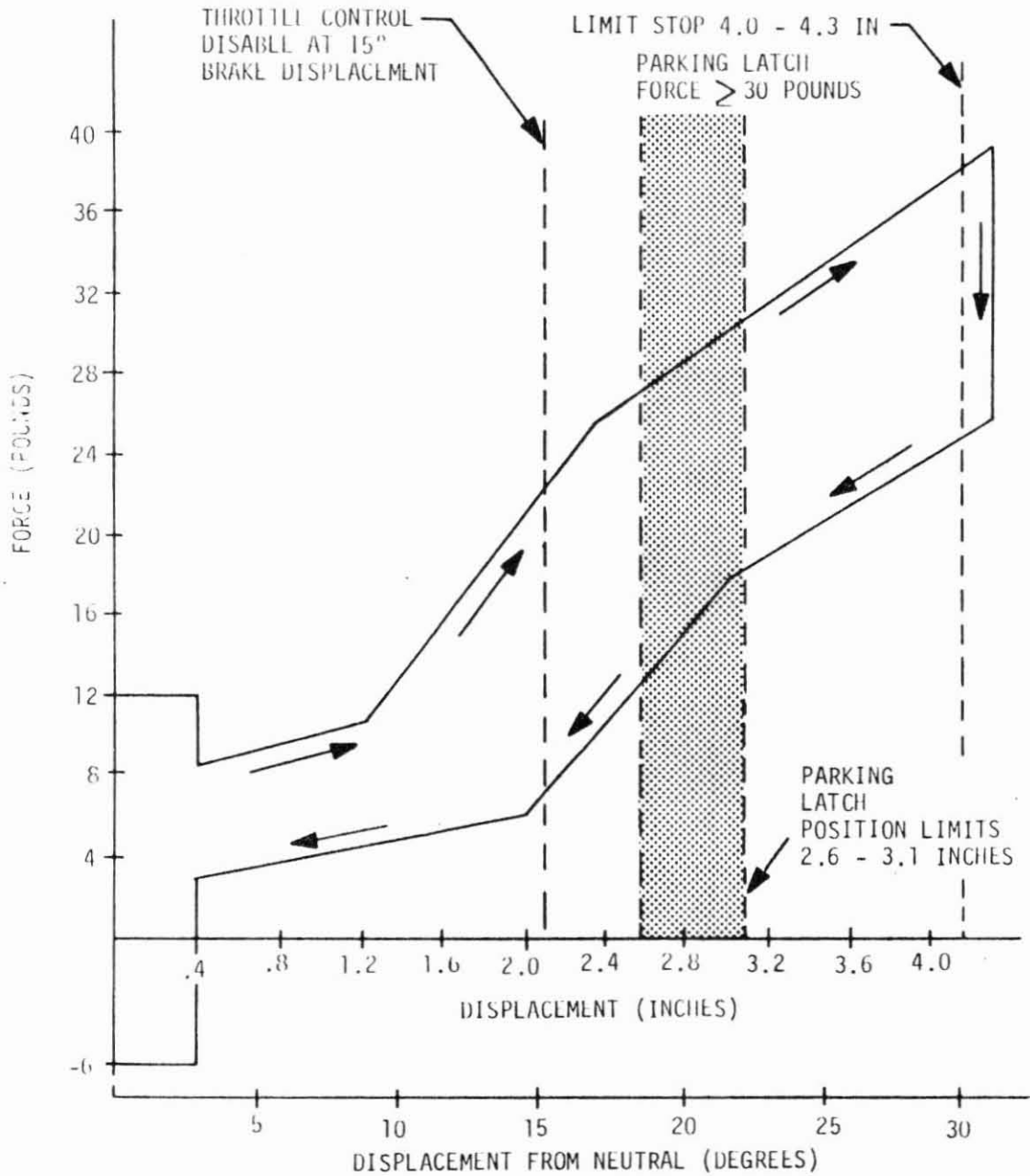

FIGURE 1-14 BRAKE CONTROL FORCE VS DISPLACEMENT

### 1.3.7 Drive Control Electronics

The Drive Control Electronics (DCE) accepts forward and reverse speed control signals from the Hand Controller and transmits them to the drive motors in a format which allows drive motor speed control. The steering logic servo amplifier assembly (previously described in paragraph 1.3.4 and figure 1-9) is also contained within the DCE. In addition, the Drive Control Electronics accepts odometer signals from the traction drives and processes the signals for odometer/speedometer readout. The basic manner of operation of the DCE is described below and illustrated in figure 1-15.

When the Hand Controller is actuated in either the forward or reverse positions, two basic signals are generated. One signal is constant voltage signal (A) to the traction drive electronics logic which tells whether the Hand Controller is on the forward or reverse side of neutral, and thus causes relay action to control the direction of drive. The other signal (B) is from the command potentiometers and is a variable voltage which reflects the amount of speed desired. This latter signal is proportional to the position of the Hand Controller and is fed to the Pulse Width Modulators (PWM) where the signal is "chopped" into pulses whose width is proportional to the incoming signal strength. The modulated signal (C) is then fed through the Drive Enable switches (astronaut operated) for each Drive Motor whose function is to determine whether the command signal for each drive motor is to be derived from PWM #1 or PWM #2. The position of the PWM select switch -- astronaut operated -- allows disabling of a defective PWM if desired.

#### \*\*\*1G Trainer Note\*\*\*

The 1G Trainer Drive Enable PWM 1 and PWM 2 positions are common "ON" positions. PWM 1 is an integral part of Drive Controller No. 1 which powers only the two front drive motors and similarly PWM 2 is an integral part of Drive Controller No. 2 which powers only the two rear motors.

After the modulated signal (C) has passed through the Drive Enable switch for each traction drive, it enters a gating switch which serves several purposes. First, it inhibits drive power if the brake is on (D). Second, if drive current becomes excessive, it inhibits drive power until the current level falls to an acceptable value (E). Third, it inhibits drive power momentarily while the Hand Controller is being switched from forward to reverse or reverse to forward (F). If none of these three inhibits is present, then the gate passes the modulated signal (C) on to the power switching driver and the power switch, which produce the proper power levels for motor control (G).

The last step prior to application of power to the motor is selection of forward or reverse motor drive. This is accomplished by the reversing relay and relay driver. The relay driver determines the position of the reversing relays and is actuated by position of the Hand Controller (forward or reverse)

LS006-002-2H  
 LUNAR ROVING VEHICLE  
 OPERATIONS HANDBOOK

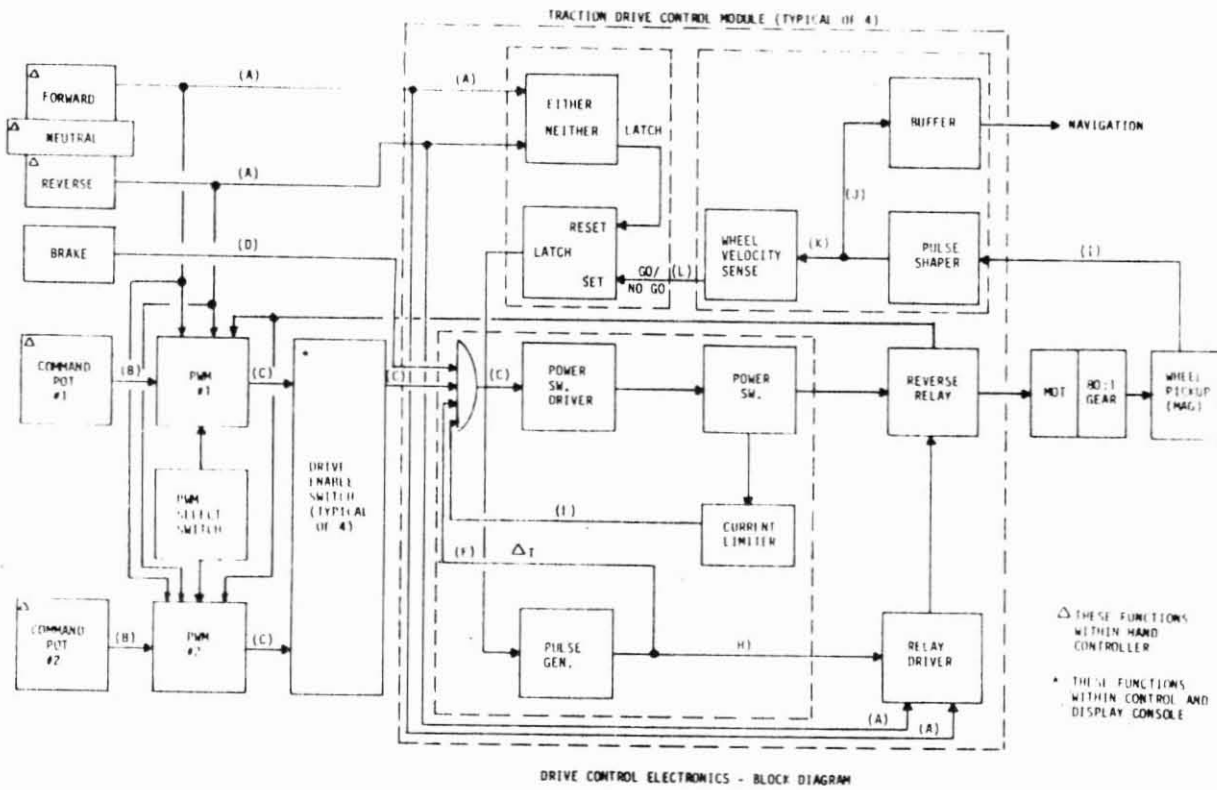

FIGURE 1-15 DRIVE CONTROL ELECTRONICS - BLOCK DIAGRAM



1.3.7 (Continued)

and a signal from the pulse generator (H) which indicates the power to the drive motor has been inhibited and switching can take place. The condition of the reversing relays determine the direction of current through the motor armature and thus the direction of rotation of the motor. The wheels are driven through 80:1 ratio harmonic drive units as explained in paragraph 1.3.3.

Each traction drive has a magnetic pickup for sensing the rotational motion of each wheel. This signal (I) is picked up as a series of pulses and transmitted back into the Traction Drive Control Module where it is properly pulse shaped for use and then used for two purposes. One, it is fed (J) through a buffer to the navigation subsystem for the odometer. Two, it is fed (K) to a wheel velocity sensing circuit which determines if the wheel velocity is greater than 1 KPH. If it is, a signal (L) is sent to the traction drive electronics logic to disallow switching from forward to reverse or reverse to forward until wheel speed drops below 1 KPH. From 1 KPH to full stop the state of the inhibit circuit may be indeterminate, thus it is imperative that the vehicle be brought to a full stop before a direction change is commanded.

#### 1.4 ELECTRICAL POWER SUBSYSTEM

The electrical power subsystem consists of two batteries, distributing wiring, connectors, switches, circuit breakers and meters for controlling and monitoring electrical power.

##### 1.4.1 Batteries

The LRV contains two primary silver zinc batteries (figure 1-16) each having a nominal voltage of 36 (+5/-3) VDC and each having a capacity of 115 ampere hours. Both batteries are normally used simultaneously on an approximate equal load basis during LRV operation by selection of various load-to-bus combinations through circuit breakers and switch settings on the control and display console.

The batteries are located on the forward chassis enclosed by the thermal blanket and dust covers (figure 1-17). Battery No. 1 (on the left side) is connected thermally to the navigation Signal Processing Unit (SPU), and serves as a partial heat sink for the SPU. Battery No. 2 (on the right side) is thermally tied to the navigation Directional Gyro Unit (DGU) and serves as a heat sink for the DGU.

The batteries are installed in the LRV on the pad at KSC in an activated condition and are monitored for voltage and temperature on the ground until approximately T-18 hours in the countdown. On the lunar surface, the batteries are monitored for temperature, voltage, output current, and remaining ampere-hours. These displays are located on the control and display panel.

Each battery is protected from excessive internal pressure by a pressure relief valve that is set to open at 3.1 to 7 PSI differential pressure. The relief valve closes when the differential pressure is below the valve's relief pressure. Each battery is capable of carrying the entire LRV electrical load, and the circuitry is designed such that in the event one battery fails, the entire electrical load can be switched to the remaining battery. LRV range capability is shown in Appendix A.

#### \*\*\*1G Trainer Notes\*\*\*

1. 1G Trainer uses two rechargeable nickel cadmium batteries having a voltage output of 34 VDC and a capacity of 24 ampere hours each. Both batteries must be used for 1G Trainer operation.
2. 1G Trainer estimated operation time before recharge for a set of batteries (two batteries per set) is 63 minutes on smooth level ground (800 pound payload configuration and 10 KPH). This estimate includes 19 minutes of stand-by time.

(Continued)

LS006-002-2H  
LUNAR ROVING VEHICLE  
OPERATIONS HANDBOOK

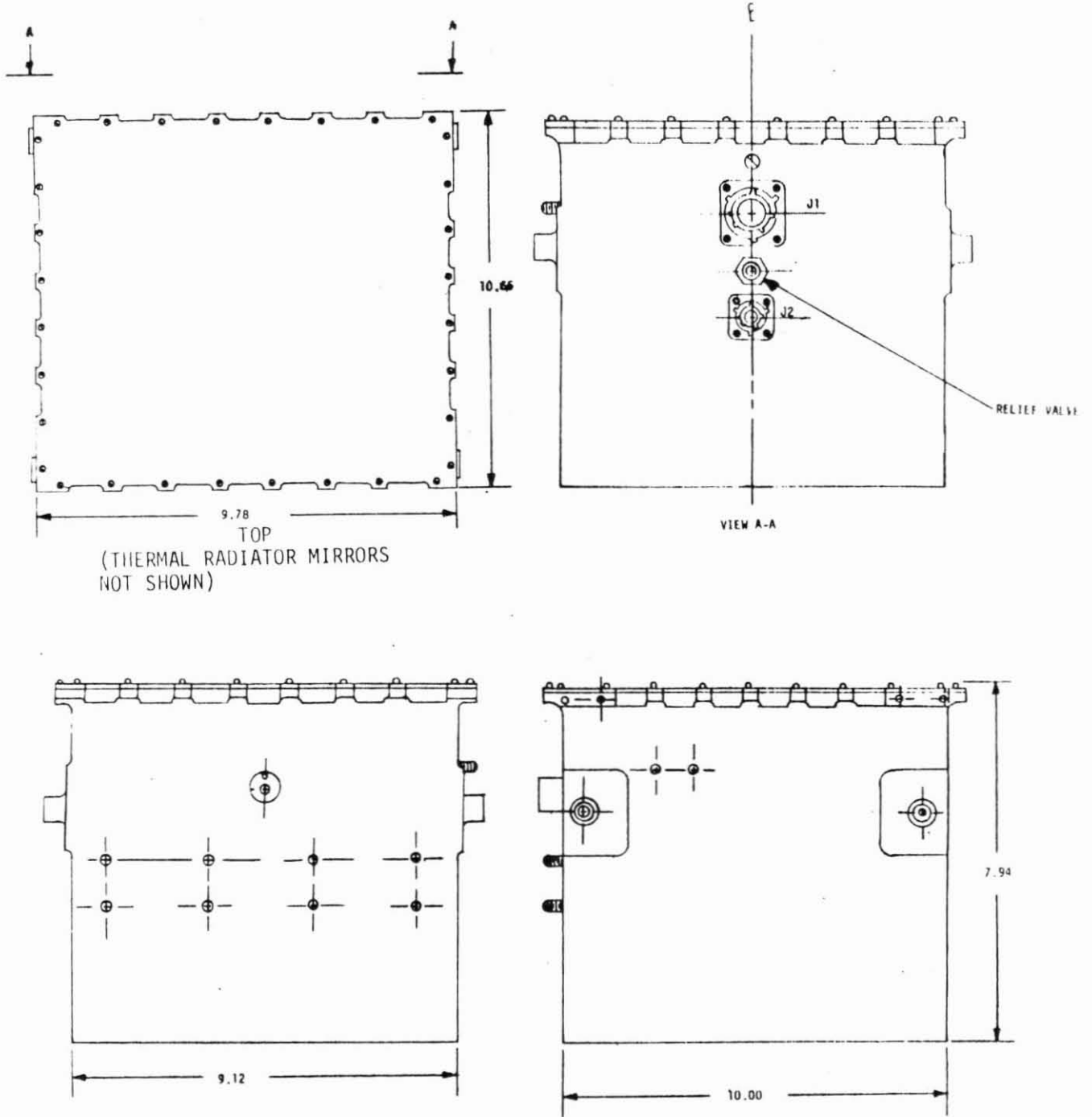

FIGURE 1-16. LRV BATTERY CONFIGURATION

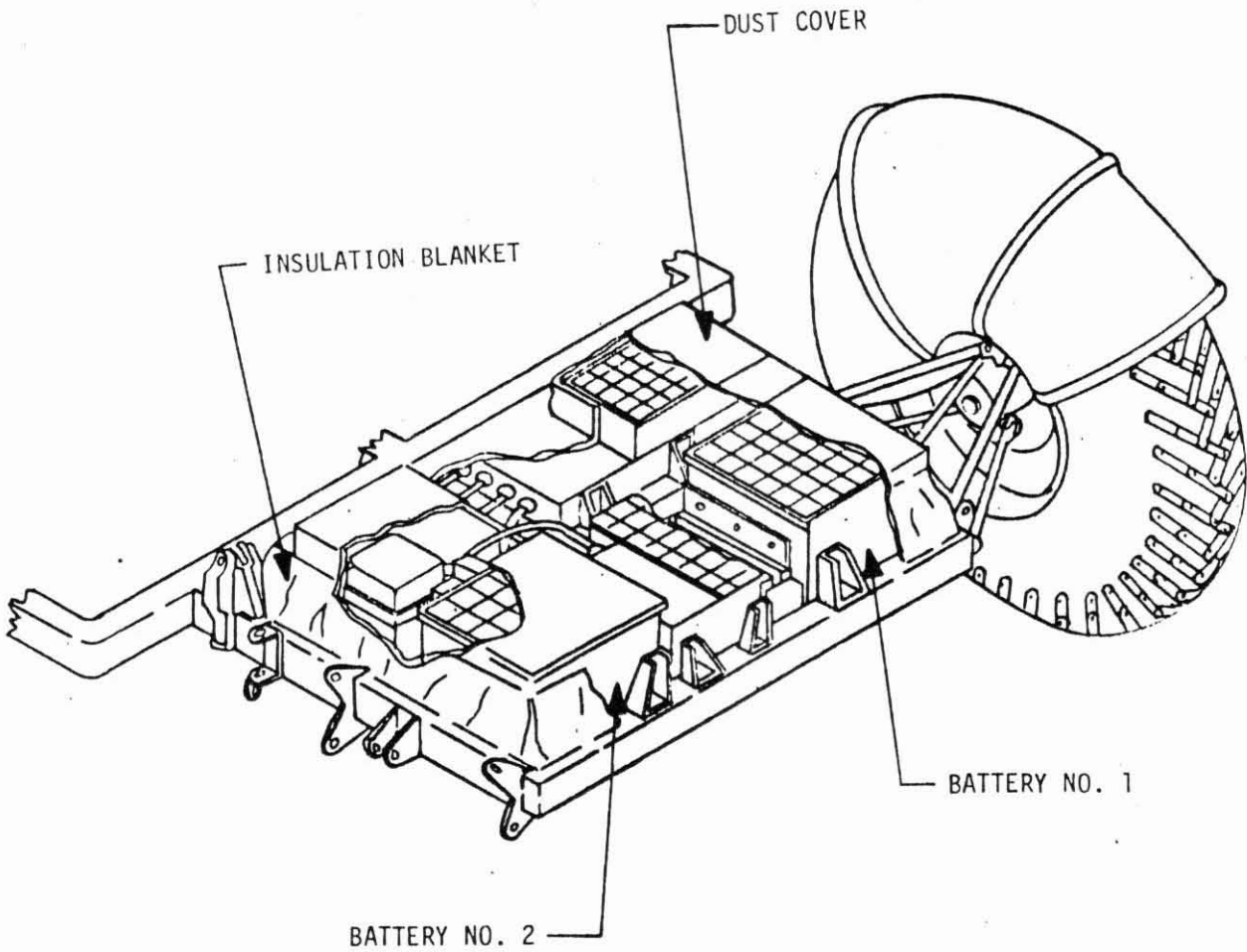

FIGURE 1-17 LRV BATTERIES, THERMAL BLANKET AND DUST COVERS

**\*\*\*1G Trainer Notes\*\*\*  
(Continued)**

3. The 1G Trainer batteries are fan cooled when internal temperatures rise above a preset thermostatic switch value. The batteries are not covered by a thermal blanket.

1.4.2 Distribution and Monitoring System

The electrical distribution and monitoring schematics for the LRV are shown in figures 1-18 and 1-19. The switch and circuit breaker arrangement is designed to allow switching any electrical load to either battery.

During normal LRV operation, the navigation system power remains on during the entire sortie. To conserve power for increased range, all mobility elements (i.e., traction drives, steering motors, electronic controller, and PWM power supplies) are turned off if a stop is to exceed 5 minutes duration.

**\*\*\*1G Trainer Note\*\*\***

The 1G Trainer has alternate provision for utilizing an external power source by means of a rotary switch selector (figure 8-3) and umbilical connector.

1.4.3 Caution and Warning System

Refer to figure 1-20 for the caution and warning system schematic. The normally open temperature switches in the batteries and drive motors close on increasing temperatures. When either battery reaches 125°F or any drive motor reaches 400°F, the temperature switch closes, energizing the "OR" logic element and the driver. The driver then sends a 10 millisecond 36V pulse to the coil of the electromagnet which releases the magnetic hold on the indicator at the top of the console and a spring loaded flag flips up. The astronaut can reset the flag by pushing it down even though the cause has not been eliminated. The flag will not flip up again unless an overtemperature occurs on another battery or traction drive or the initial overtemperature subsides and then re-occurs.

**\*\*\*1G Trainer Notes\*\*\***

1. The 1G Trainer traction drive gear box thermal switches will actuate the warning flag when gear box temperature reaches 200°F. The gear box temperature readout is biased so a reading of 450°F to 500°F will exist when the thermal switch actuates.
2. The 1G Trainer motor temperature switches are set to actuate the flag when motor external case temperature reaches 225°F. This temperature at the case would correspond to a rotor temperature of about 450°F.

LS006-002-2H  
LUNAR ROVING VEHICLE  
OPERATIONS HANDBOOK

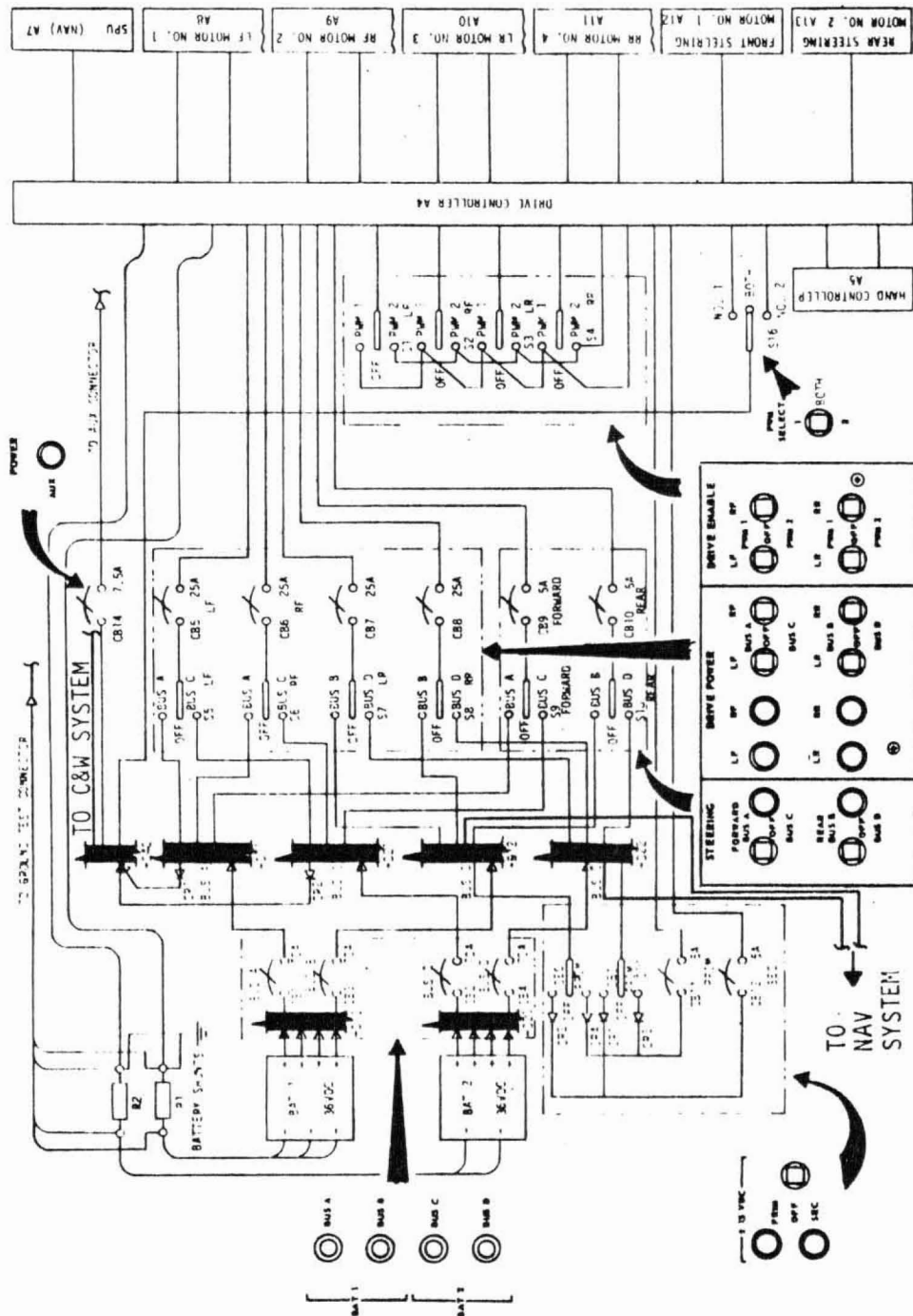

FIGURE 1-18 POWER DISTRIBUTION SYSTEM SCHEMATIC

LS006-002-2H  
LUNAR ROVING VEHICLE  
OPERATIONS HANDBOOK

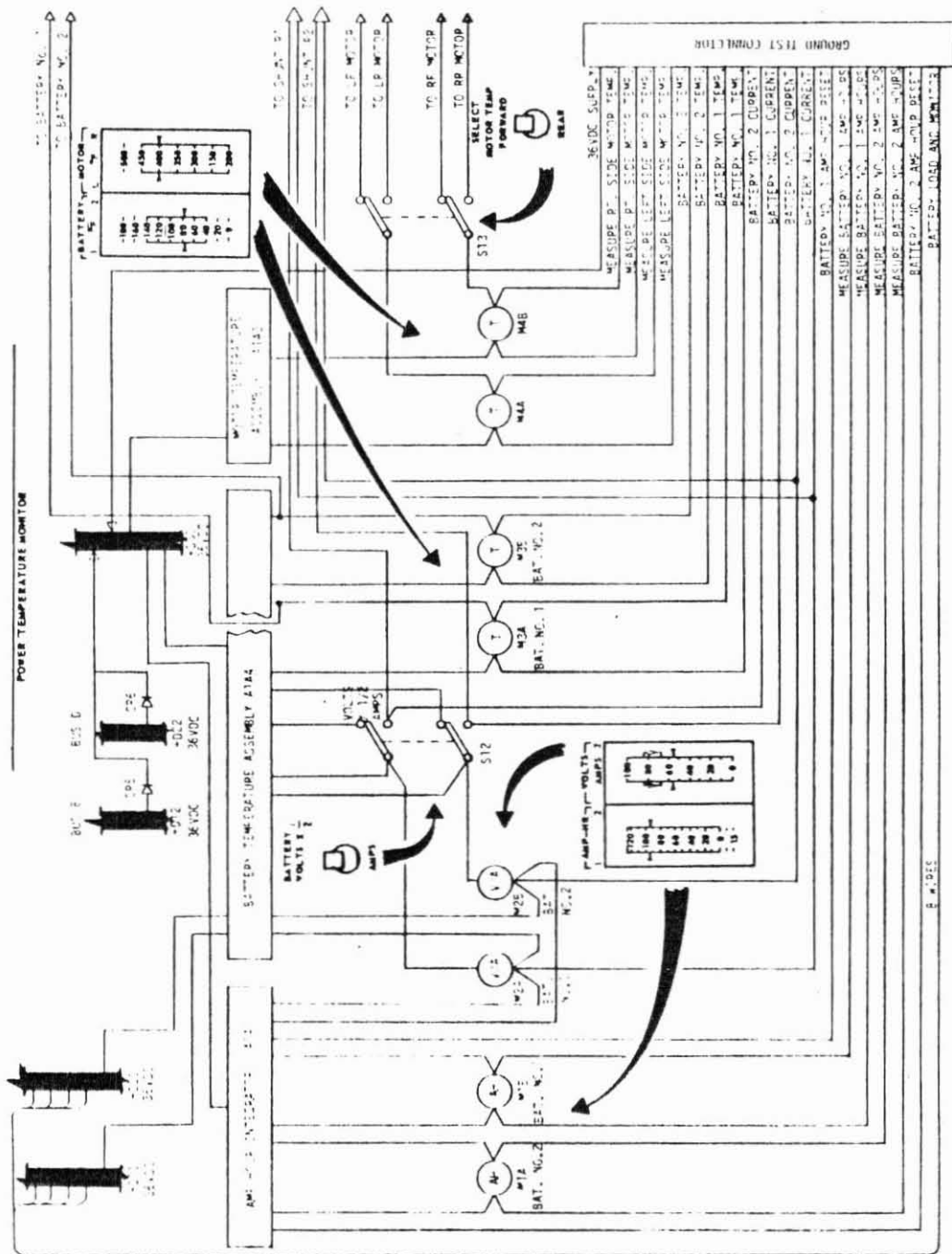

FIGURE 1-19 LRV MONITOR SCHEMATIC

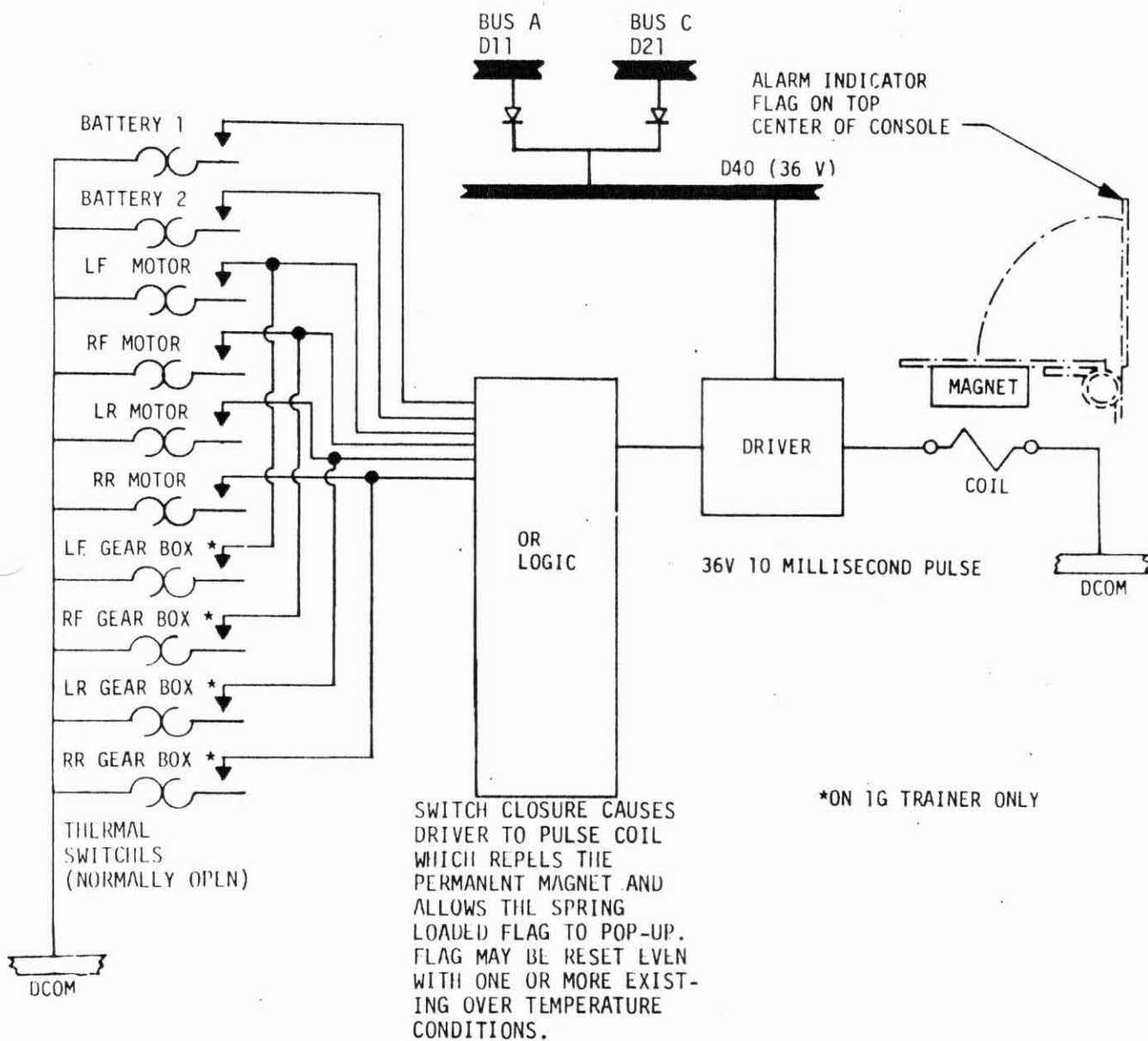

FIGURE 1-20. CAUTION AND WARNING SYSTEM



LS006-002-2H  
LUNAR ROVING VEHICLE  
OPERATIONS HANDBOOK

---

1.4.4 Auxiliary Connector

The auxiliary connector (figure 1-21) provides power for the Lunar Communications Relay Unit (LCRU). Power at the connector is furnished at 36 (+5/-3) VDC through a 7.5 ampere circuit breaker. Source impedance at the connector is less than 0.4 ohms shunted by a 440 micro-farad capacitor. Prior to launch, the LCRU power cable is attached to the auxiliary connector.

\*\*\*1G Trainer Note\*\*\*

The 1G Trainer auxiliary connector is not electrically functional.

LS006-002-2H  
LUNAR ROVING VEHICLE  
OPERATIONS HANDBOOK

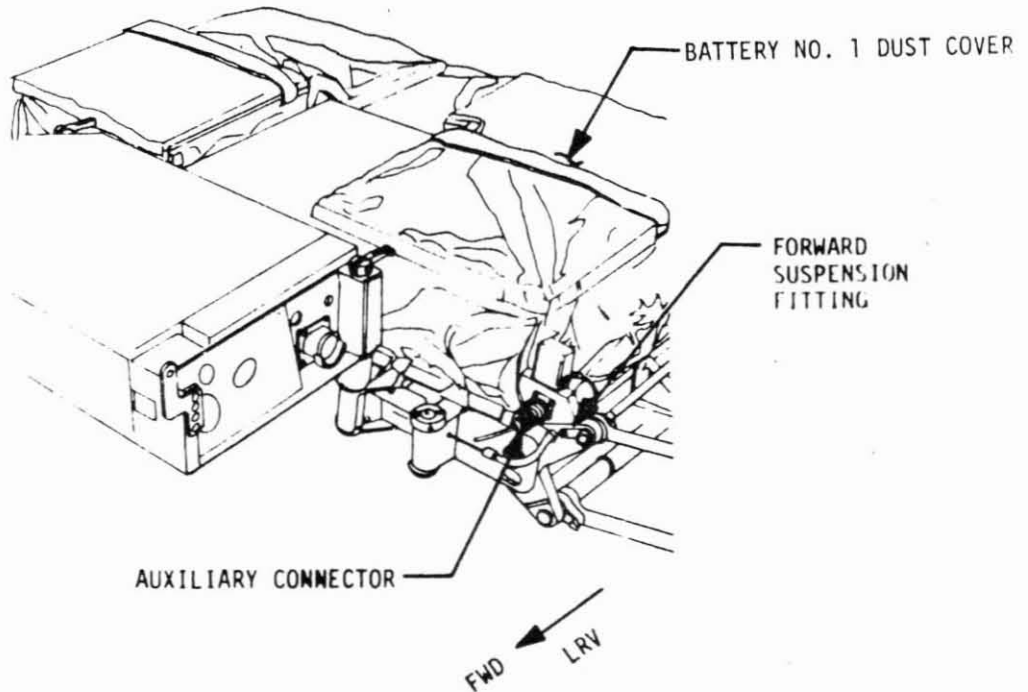
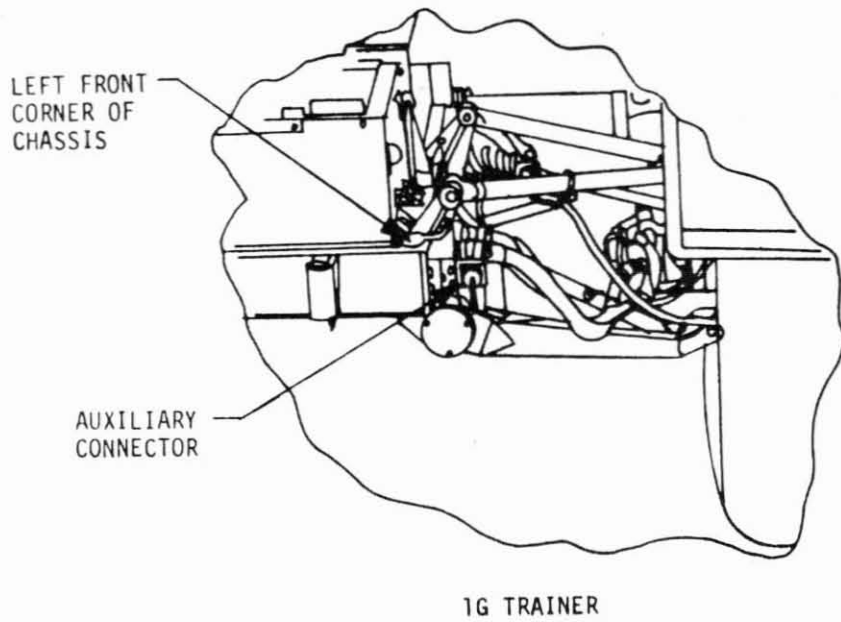

FIGURE 1-21. AUXILIARY CONNECTOR LOCATION

## 1.5 CONTROL AND DISPLAY CONSOLE

The Control and Display Console (figure 1-22) is separated into two main functional parts: Navigation on the upper part of the panel and monitoring and controls on the lower part of the panel. Refer to Table 1-1 for controls and use. The Control and Display Panel is activated with a radioluminescent material (Promethium) which provides visibility of displays even under lunar shadow conditions.

### 1.5.1 Attitude Indicator

This instrument (figure 1-26) provides indications of LRV pitch and roll. It indicates PITCH upslope (U) or downslope (D) within a range of plus 25 to minus 25 degrees in five degree increments and indicates ROLL within a range of 25 degrees left to 25 degrees right in one degree increments. The damper on the side of the indicator can be lifted to damp out oscillations. The pitch indication is readable in the stowed position of the indicator. The indicator is rotated outward which exposes the ROLL scale to the left side crewman. The pitch and roll reading is transmitted to MCC for navigation update computation.

### 1.5.2 Heading Indicator

This instrument displays the LRV heading with respect to lunar north. The initial setting and updating of this instrument is accomplished by operating the GYRO TORQUING switch LEFT or RIGHT.

### 1.5.3 Bearing Indicator

This instrument displays bearing to the LM in one degree digits. In the event of power loss to the navigation system, the bearing indication will remain displayed. The indications are lost when power is reapplied to the navigation system, however.

#### NOTE

Insufficient data is available for bearing computation until the LRV has moved about 50 meters from the point of nav initialization, therefore, the display indication should be disregarded until the vehicle is at least 50 meters from the point of nav initialization.

### 1.5.4 Distance Indicator

#### NOTE

Operating the LRV in reverse will add to the distance displayed on this instrument.

LS006-002-2H  
LUNAR ROVING VEHICLE  
OPERATIONS HANDBOOK

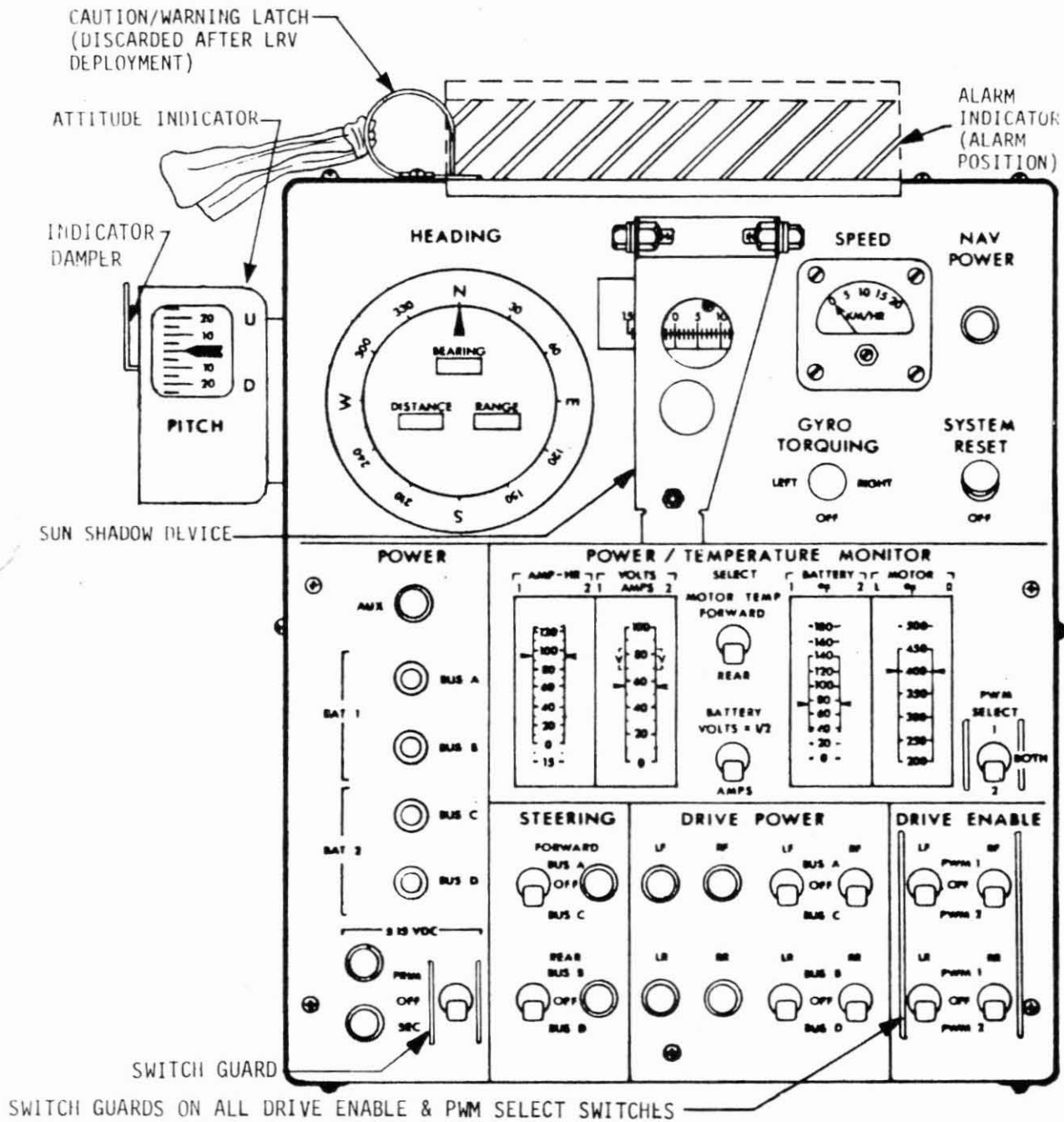

FIGURE 1-22 CONTROL AND DISPLAY CONSOLE

Mission

J

Basic Date

12/4/70

Change Date

4/19/71

Page 1-39

| CONTROL                    | USE  |
|----------------------------|--|
| GYRO TORQUING Switch       | Adjusts heading indication during navigation updating. Switch is locked OFF in center position.                              |
| NAV POWER CB (5.0 Amps)    | Routes power from main busses to navigation system.  |
|                            | NOTE   |
|                            | When Nav Power CB is open SPEED METER does not function.   |
| AUX CB (7.5 Amps)          | Energizes LRV Auxiliary Connector for LCRU power.  |
| BAT 1 BUS A CB (70.0 Amps) | Energizes Bus A from LRV Battery No. 1.  |
| BAT 1 BUS B CB (70.0 Amps) | Energizes Bus B from LRV Battery No. 1.  |
| BAT 2 BUS C CB (70.0 Amps) | Energizes Bus C from LRV Battery No. 2.  |
| BAT 2 BUS D CB (70.0 Amps) | Energizes Bus D from LRV Battery No. 2.  |
| + 15 DC PRIM CB (5.0 Amps) | Routes power from + 15 DC PRIM/SEC Switch to 15 VDC power supplies and protects primary + 15 VDC power supply from overload. |
| + 15 DC SEC CB (5.0 Amps)  | Redundant to + 15 DC PRIM CB and protects secondary + 15 VDC power supply from overload.                                     |
| + 15 DC PRIM/SEC Switch    | Routes 36 VDC power from Bus B or D through + 15 VDC CB's and on to 15 VDC Power Supplies in Motor Controller.               |
| SYSTEM RESET Switch        | Resets BEARING, DISTANCE and RANGE indicators to zero.   |
| AMP-HR Indicator           | Monitors battery residual capacity.  |
| VOLTS/AMPS Indicator       | Monitors battery volts or LRV current (amps) consumption.  |

TABLE 1-1 CONTROL AND DISPLAY CONSOLE CONTROLS

| CONTROL                           | USE  |
|-----------------------------------|--|
| MOTOR TEMP SELECT Switch          | Selects Forward or Rear drive motors to be monitored on MOTOR °F indicator.  |
| Battery Select Switch             | Selects battery voltage or current to be displayed on VOLTS AMPS indicator.  |
| Battery °F Meter                  | Monitors temperature of batteries. Allowable temperature is 40°F to 125°F for each battery.  |
| MOTOR °F Meter                    | Monitors temperature of each motor. Allowable temperature is 400°F for each drive motor.   |
| PWM SELECT Switch                 | Energizes Pulse Width Modulators (PWM's) in Motor Controller. With Switch in position 1 or 2, only corresponding PWM is energized. With switch in position BOTH, both PWM's are energized. |
| FORWARD STEERING Switch           | Selects Bus A or C to supply power to Forward Steering Motor.  |
| REAR STEERING Switch              | Selects Bus B or D to supply power to Rear Steering Motor.   |
| FORWARD STEERING CB (5.0 Amps)    | Protects Forward Steering Motor from overload current.   |
| REAR STEERING CB (5.0 Amps)       | Protects Rear Steering Motor from overload current.  |
| DRIVE ENABLE Switches             | Switches LF, RF, LR and RR - Select PWM 1 or 2 for control of drive motors.  |
| DRIVE POWER Switches              | Switches LF, RF, LR and RR - Select desired bus to supply power to drive motors.   |
| DRIVE POWER CB's (25.0 Amps each) | Protects the four drive motors from overload damage.   |

TABLE 1-1 CONTROL AND DISPLAY CONSOLE CONTROLS  
(Continued)

LS006-002-2H  
LUNAR ROVING VEHICLE  
OPERATIONS HANDBOOK

---

1.5.4 (Continued)

This instrument displays distance traveled by the LRV in increments of 0.1 kilometer. This display is driven from the navigation signal processing unit which receives its inputs from the third fastest traction drive odometer. Total digital scale capacity is 99.9 km. In the event of power loss to the navigation system the distance indicator at time of power loss will remain displayed.

1.5.5 Range Indicator

This instrument displays the distance to the LM, and is graduated in 0.1 km increments with a total digital scale capacity of 99.9 km. In the event of power loss to the navigation system the range indicated at time of power loss will remain displayed.

1.5.6 Speed Indicator

NOTE

When the NAV POWER circuit breaker is open, no speed indication will be attained.

The instrument shows LRV velocity from 0 to 20 km/hr. This display is driven from the odometer pulses from the right rear wheel, through the SPU.

1.5.7 Sun Shadow Device

This device is used to determine the LRV heading with respect to the sun azimuth. When deployed, the device casts a shadow on a graduated scale when the vehicle is facing away from the sun. The point at which the shadow intersects the scale is transmitted by the crew to MCC for navigation update. The scale length is 15 degrees either side of zero with one degree divisions. The sun shadow device can be utilized at sun elevation angles up to 75 degrees.

## 1.6 NAVIGATION SUBSYSTEM

Refer to figure 1-23 for the Navigation Subsystem Block Diagram; figure 1-24 for hardware locations, and figure 1-25 for electrical schematic.

The power supply converts the vehicle battery voltage to the AC and DC voltages required for operation of the navigation subsystem components. Signal outputs to the subsystem are: direction (obtained from a directional gyro) and distance (obtained from odometer pulses from each traction drive unit). These signals are operated on by the navigation subsystem which displays the results as: heading with respect to lunar north, bearing back to the LM, range back to the LM, total distance traveled and velocity.

### NOTE

The Navigation System is initialized by pressing the SYSTEM RESET button, which resets all digital displays and internal registers to zero. Initialization is only performed at the start of each EVA.

Alignment of the directional gyro is accomplished by measuring the pitch and roll of the LRV using the attitude indicator (figure 1-26), and measuring the LRV orientation with respect to the sun using the sun shadow device (figure 1-27). This information is relayed to MCC where a heading angle is calculated. The gyro is then adjusted by slewing with the torquing switch until the heading indicator reads the same as the calculated value. Slew rate is approximately 1.5 degrees per second.

The heading angle of the LRV is implicit in the output from the gyro, which is generated by a three wire synchro transmitter. The heading indicator in the IPI contains a synchro control transformer and an electromechanical servo system which drives the control transformer until a null is achieved with the inputs from the gyro.

### NOTE

The odometer logic cannot distinguish between forward and reverse wheel rotation. Therefore, reverse operation of the LRV adds to the odometer reading.

There are four odometers in the system, one for each traction drive unit. Nine odometer pulses are generated for each revolution of each wheel. These signals are amplified and shaped in the motor controller circuitry and enter the line receiver in the SPU. The odometer pulses from the right rear wheel enter the velocity processor for display on the LRV SPEED indicator.



LS006-002-2H  
 LUNAR ROVING VEHICLE  
 OPERATIONS HANDBOOK

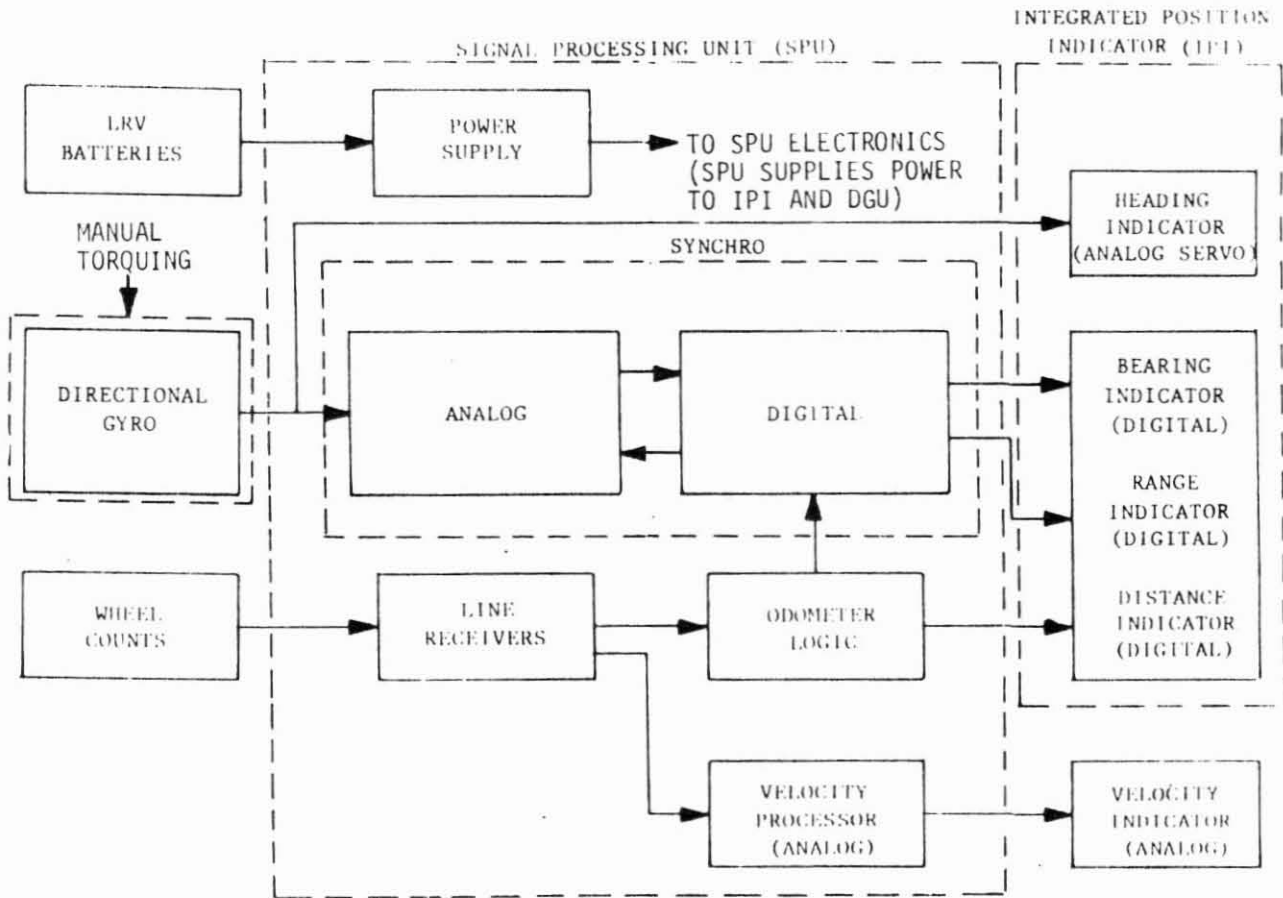

FIGURE 1-23. NAVIGATION SUBSYSTEM BLOCK DIAGRAM

LS006-002-2H  
LUNAR ROVING VEHICLE  
OPERATIONS HANDBOOK

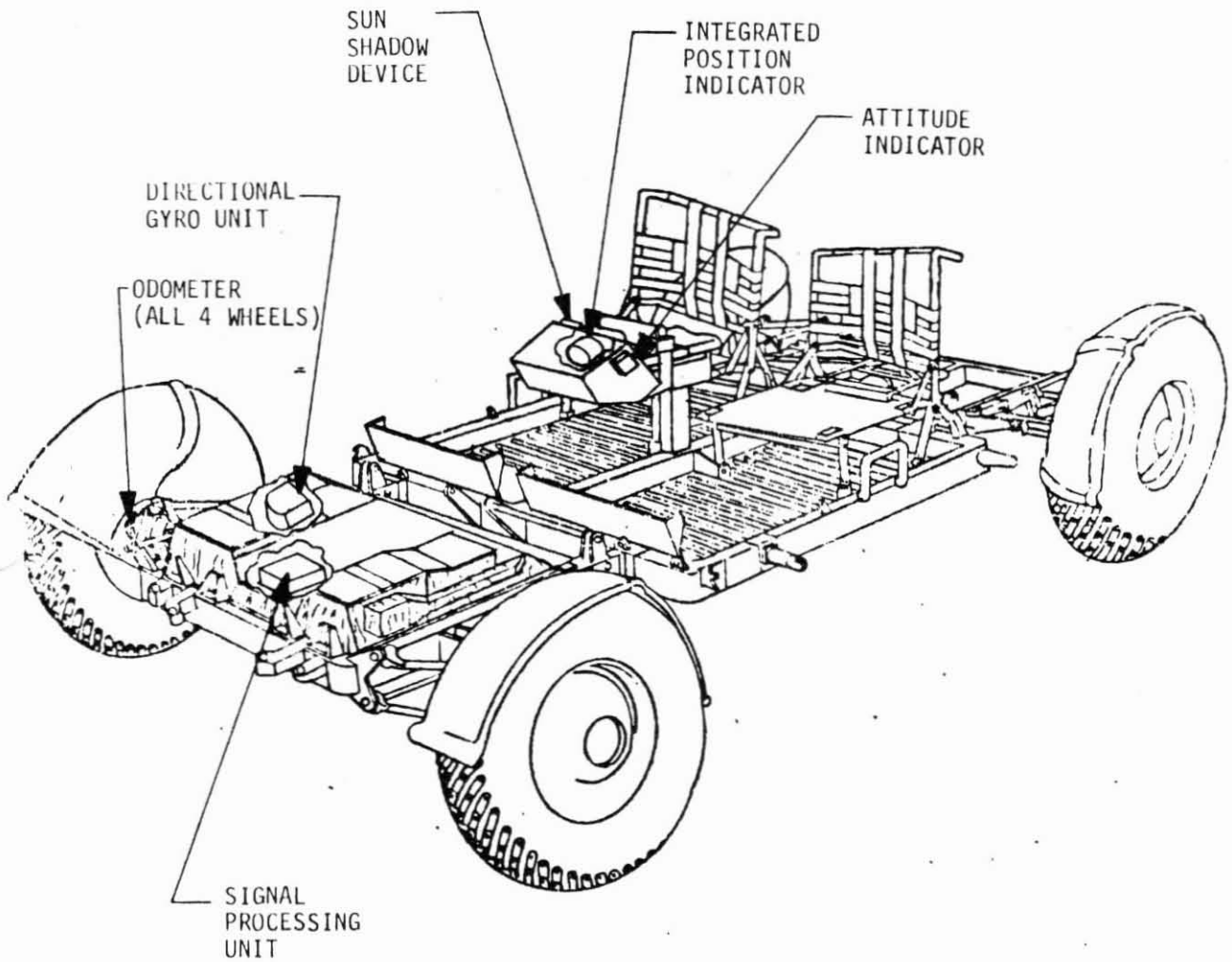
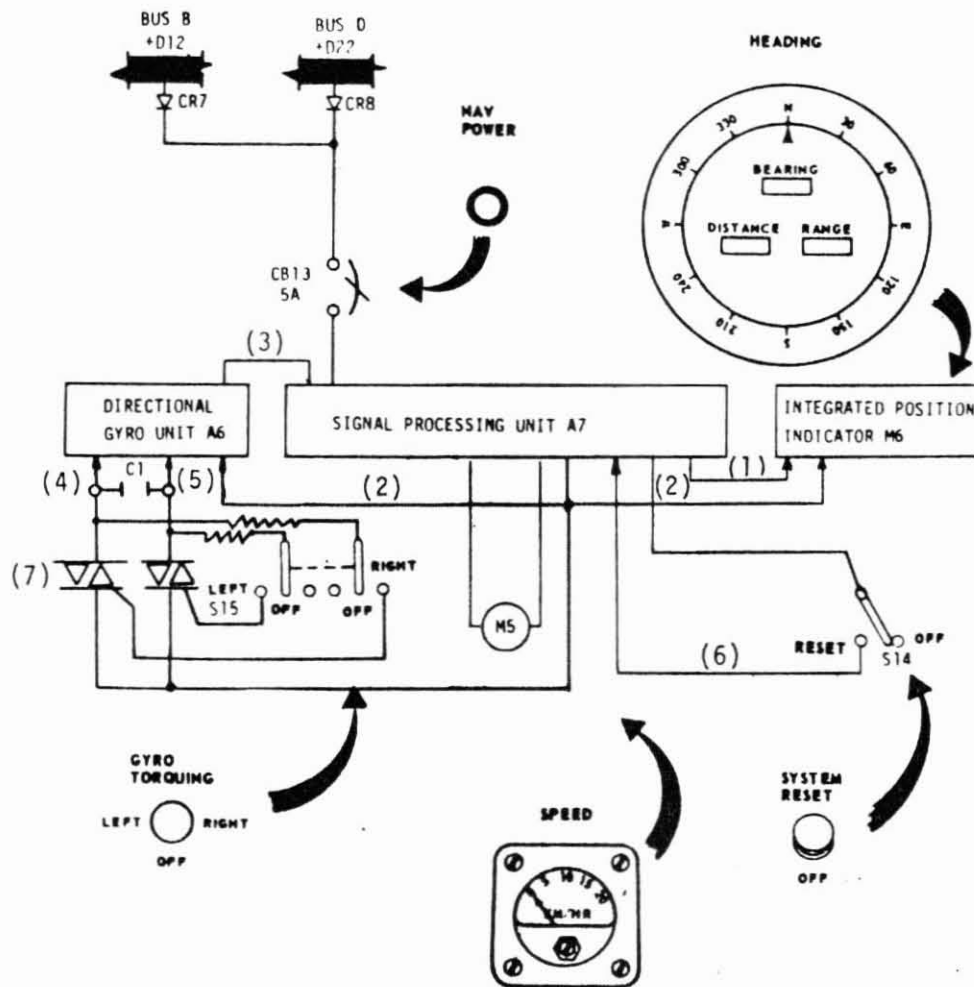

FIGURE 1-24. NAVIGATION COMPONENTS ON LRV

LS006-002-2H  
LUNAR ROVING VEHICLE  
OPERATIONS HANDBOOK



LEGEND

1. 3 WIRE SYNCHRO POSITIONING SIGNAL AND 3 WIRES TO INCREMENT COUNTERS.
2. 400 Hz ELECTRICAL POWER.
3. POSITION SYNCHRO OUTPUT FROM GYRO.
4. TORQUE RIGHT INPUT SIGNAL.
5. TORQUE LEFT INPUT SIGNAL.
6. DIGITAL DISPLAY RESET SIGNAL.
7.  SYMBOL INDICATES "TRIAC" (BI-DIRECTIONAL TRIODE THYRISTOR).

FIGURE 1-25 NAVIGATION SYSTEM ELECTRICAL SCHEMATIC

LS006-002-2H  
LUNAR ROVING VEHICLE  
OPERATIONS HANDBOOK

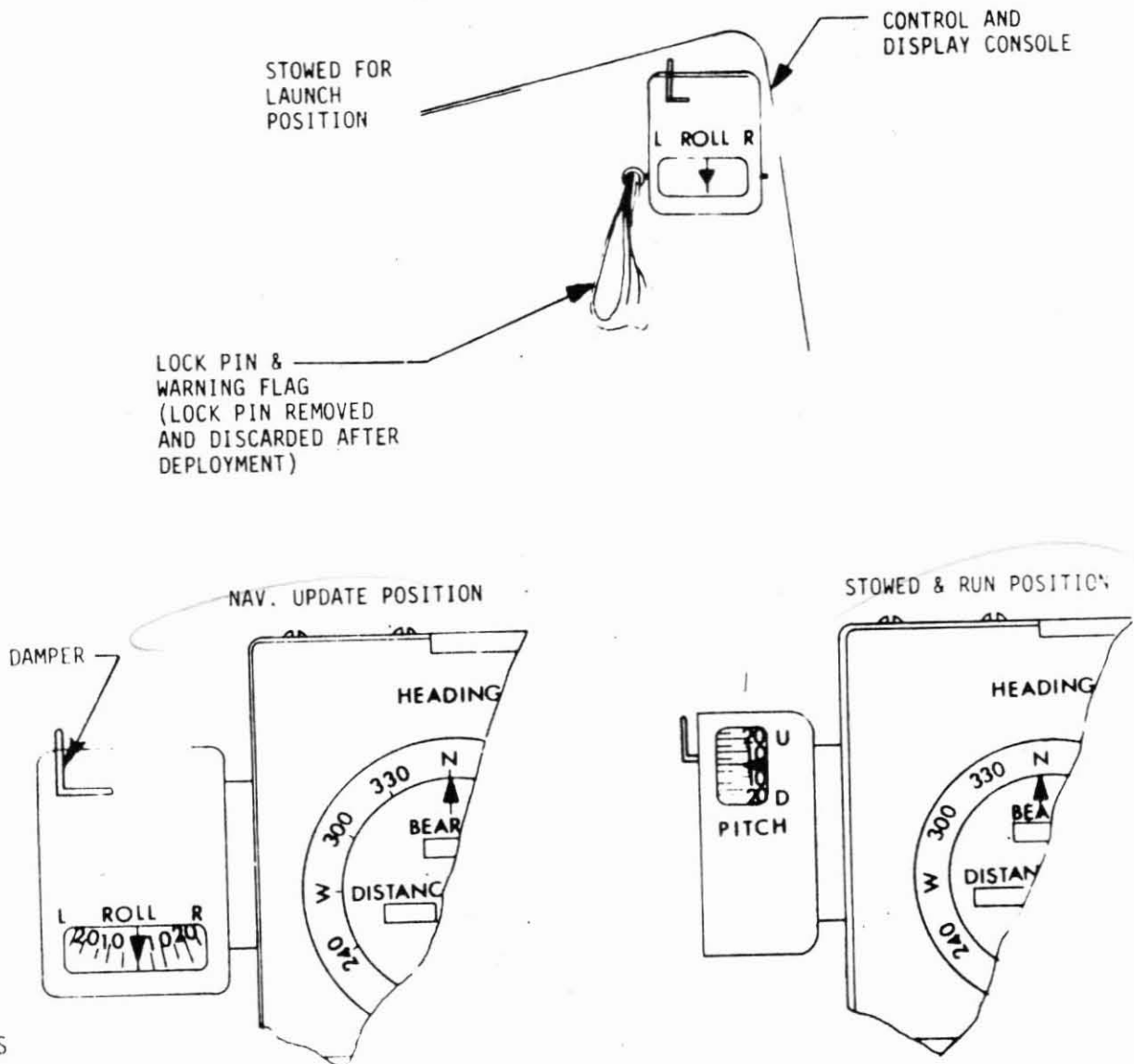

NOTES

1. POINTER MOVES, SCALE IS FIXED
2. NOMENCLATURE ON CASE EXTERIOR IS NOT ACTIVATED WITH RADIOLUMINESCENT MATERIAL

FIGURE 1-26 VEHICLE ATTITUDE INDICATOR

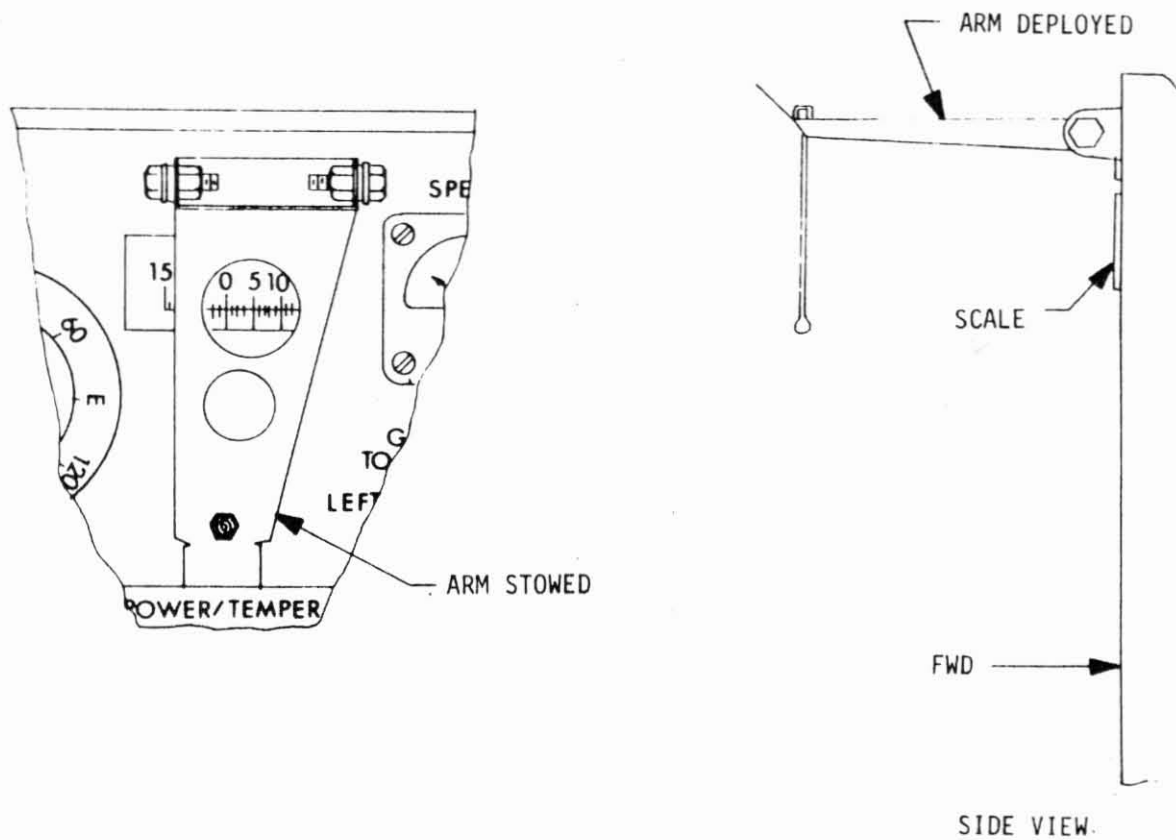

FIGURE 1-27 SUN SHADOW DEVICE

\*\*\*IG Trainer Note\*\*\*

The IG Trainer navigation system is calibrated for use with the wire wheels, however, the navigation errors incurred when pneumatic tires are used are small. This is because the effective radius of both types of wheels are approximately the same, (pneumatic tires inflated to 30 psig) and the pneumatic wheel has essentially no slip. The only error incurred is in the range and distance calculation. The distance display when pneumatic wheels are used is estimated to be about 3.5% low. The ability to navigate back to the starting point during training should not be affected as all other errors cancel on a closed course.

Odometer pulses from all four wheels enter the odometer logic via the SPU line receivers. This logic selects the third fastest wheel for use in the distance computation. This insures that the odometer output pulses will not be based on a wheel which is locked, nor will they be based on a wheel that has excessive slip.

NOTE

Loss of Nav information occurs if vehicle is operated with more than one traction drive shut off.

The odometer logic sends outputs to the digital distance indicator in the IPI and to the range/bearing processor in the SPU. Upon entering the range/bearing processor, the outputs initiate selection, and conversion of heading, sine and cosine to digital numbers.

The effect of conversion of heading, sine and cosine, at distance increments is equivalent to entering (distance increment x sine heading) and (distance increment x cosine heading) into the  $\Delta E$  and  $\Delta N$  registers of the digital part of the bearing and range processor. The digital processor then adds the new  $\Delta E$  and  $\Delta N$  numbers to the contents of the East (E) and North (N) accumulators. The E and N accumulators, therefore, contain the east and north vector components of the range and bearing back to the LM. The digital vectoring process then does a vector conversion on the N and E numbers to obtain range and bearing, which are displayed on digital counters in the IPI. Each distance increment from the odometer logic initiates the entire sequence described, and results in the updating of bearing and range.

NOTE

The bearing digital display is "locked out" (i.e. does not display updated readings) until the vehicle is driven beyond a 50 meter radius of the nav initialization point.

## 1.7 CREW STATION

The crew station consists of seats, footrests, inboard handholds, outboard handholds, arm rest, floor panels, seat belts, fenders, and toeholds.

### 1.7.1 Seats

LRV seats are tubular aluminum frames spanned by nylon (figure 1-28). The seats are folded flat onto the center chassis for launch and erected to the operational position by the crew after LRV deployment on the lunar surface. The seat back is used to support and restrain the PLSS from lateral motion when the crew is positioned for LRV operation. Refer to Section 2 for seat erection sequence. The seat bottom contains a cutout to allow access to the PLSS flow control valves and includes provisions for vertical support of the PLSS.

#### \*\*\*1G Trainer Note\*\*\*

The 1G Trainer is also equipped with removable seat pads which allow comfortable operation in a "shirt sleeve" training session.

### 1.7.2 Footrests

For launch, the footrests (figure 1-28) are stowed against the center chassis floor and secured by two velcro straps. The footrests are deployed by the crew on the lunar surface. The footrests are adjusted, before launch, to accommodate specific crewmen.

### 1.7.3 Inboard Handholds

Inboard handholds (figure 1-28) are constructed of 1 inch O. D. aluminum tubing and are used to aid the crew during ingress and egress. The handholds also contain payload attach receptacles for the 16 mm data acquisition camera and the LCRU low gain antenna.

### 1.7.4 Outboard Handholds

Outboard handholds are integral parts of the chassis (figure 1-28) and are used to provide crew comfort and stability when seated on the LRV and for attachment of the seat belt.

### 1.7.5 Arm Rest

The arm rest (figure 1-28) is used to support the arm of crewmen during hand controller manipulation.

LS006-002-2H  
LUNAR ROVING VEHICLE  
OPERATIONS HANDBOOK

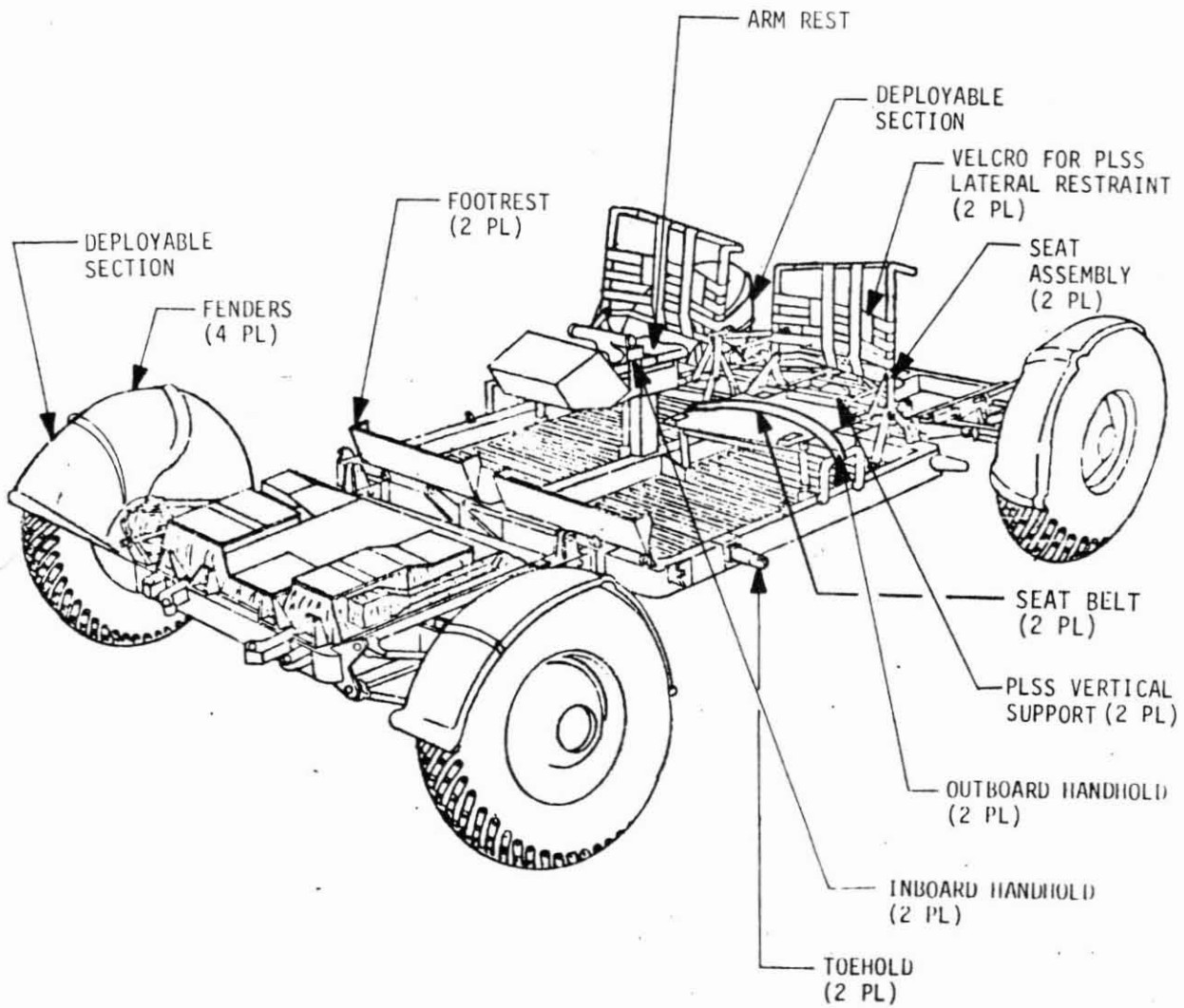

FIGURE 1-28 CREW STATION COMPONENTS



1.7.6                    Seat Belts

NOTE

Before egress, the seat belt should be attached to the inboard handhold for accessibility upon ingress.

A seat belt is provided at each seat. The seat belts (figure 1-29) are constructed of nylon webbing. The belt end terminates in a hook which is secured to the outboard handhold. Belt length adjustment is provided by an adjustment buckle. A stretch section of the belt permits normal fastening and release.

1.7.7                    Fenders

The deployable portion of each fender (figure 1-28) is positioned by the astronaut during LRV deployment on the lunar surface.

1.7.8                    Toeholds

There are two toeholds, one on either side of the vehicle. The toehold is used to aid the crew in ingressing and egressing the LRV. The toehold is formed by dismantling the LRV/LM interface tripods and using the leg previously used as the tripod center member as the toehold. The tripod member is inserted into the chassis receptacle to form the operational position of the toehold.

NOTE

The toeholds are also used as tools to actuate the wheel-decoupling mechanism to release the telescoping tubes and saddle fitting on the forward chassis, and to free the steering decoupling rings from the stowed position. Either toehold may be used for decoupling.

1.7.9                    Floor Panels

The floor panels in the crew station area are beaded aluminum panels (figure 1-30). The floor is structurally capable of supporting the full weight of standing astronauts in lunar gravity.

\*\*\*1G Trainer Note\*\*\*

The 1G Trainer floor panels are flat plates in lieu of beaded panels.

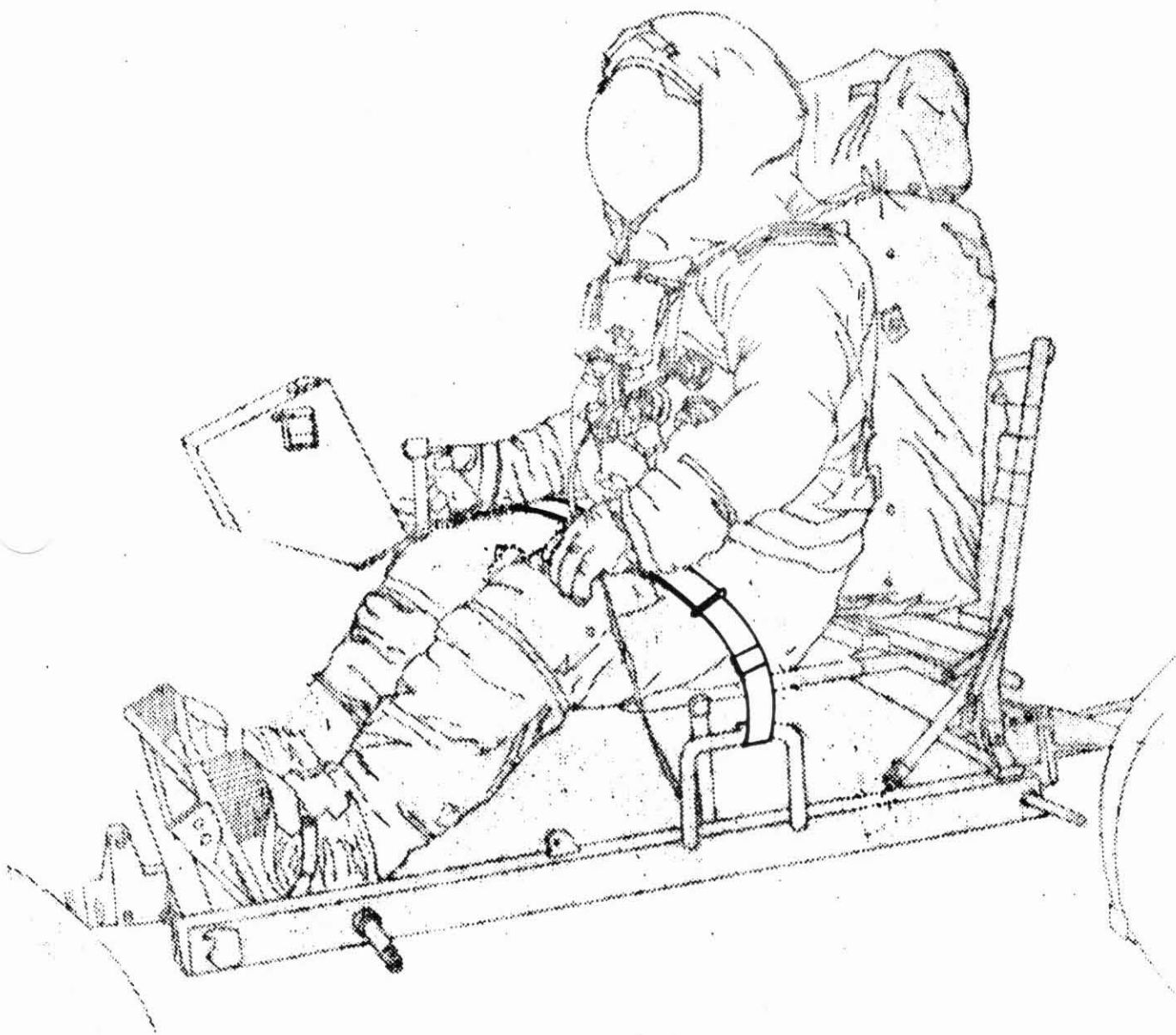
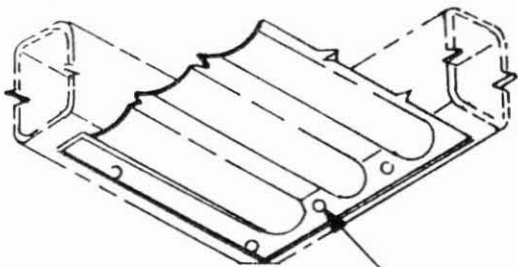
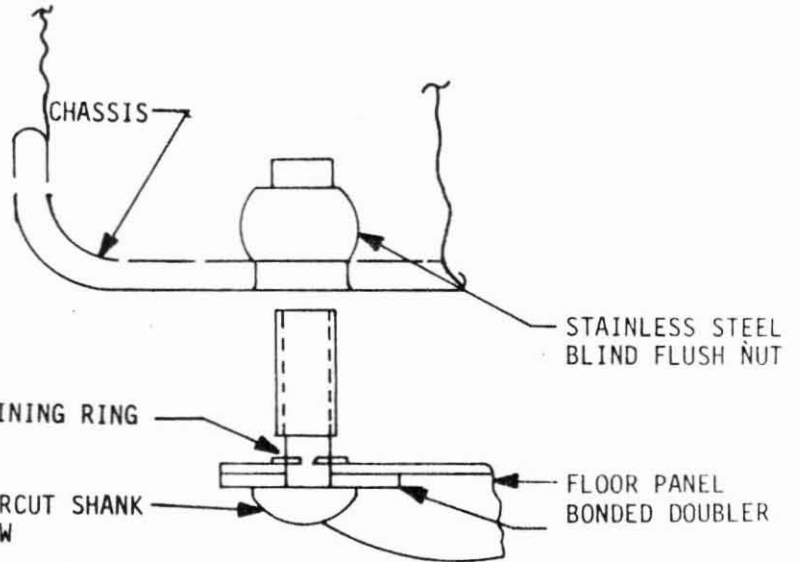
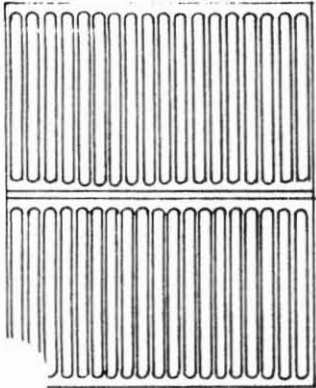
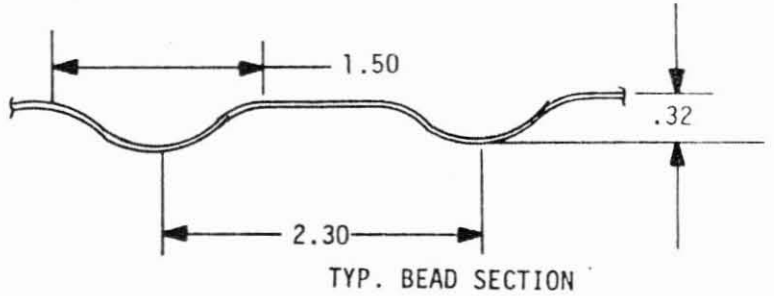

FIGURE 1-29 SEAT BELTS

CENTER CHASSIS  
 SECTIONS  
 .020 X 27.65 X 52.00



LOOKING FROM UNDERSIDE  
 OF VEHICLE



CRES STEEL NUTS  
 BONDED DOUBLER AND #10 SCREW

FIGURE 1-30 CREW STATION FLOOR PANELS

1.8 THERMAL CONTROL

1.8.1 LRV Thermal Control

Thermal control systems are incorporated into the LRV to maintain temperature sensitive components within the appropriate temperature limits during the translunar phase of a mission, during operation on the lunar surface, and during periods of inoperation on the lunar surface. Thermal control systems consist of special surface finishes, multilayer insulation, space radiators, second surface mirrors, thermal straps, and fusible mass heat sinks (figure 1-31).

\*\*\*1G Trainer Note\*\*\*

Thermal control for the 1G Trainer is described in paragraph 1.8.5.

1.8.2 Forward Chassis Thermal Control

The basic concept of thermal control for forward chassis components is energy storage during operation with subsequent energy transfer to deep space while the vehicle is parked between sorties. During operation heat energy released in the Drive Control Electronics (DCE) is stored in the DCE and the DCE thermal control unit (figure 1-32). Heat energy released in the Signal Processing Unit (SPU) is stored in the SPU, the SPU thermal control unit (a fusible mass device) and Battery No. 1. The SPU is thermally connected to Battery No. 1 by means of the SPU thermal strap (figure 1-33). Heat energy released in the Directional Gyro Unit (DGU) is stored in the DGU and Battery No. 2 by means of the DGU thermal strap. Space radiators are mounted on the top of the SPU, DCE, Battery 1 and Battery 2 (figure 1-34). Fused silica second surface mirrors are bonded to the radiators to minimize the solar energy absorbed by an exposed radiator, and to minimize the degradation of the radiating surface by the space and lunar environment. The space radiators are exposed only during the parking period between sorties. During sortie operation the space radiators are protected from the lunar surface dust by three dust covers (figure 1-31). The first dust cover protects the radiators on Battery No. 1 and the DCE. The second dust cover protects the SPU radiator. The third dust cover protects the radiator on Battery No. 2. These dust covers are opened manually at the end of the sortie, an over center latch (figure 1-35), holds the dust covers open until battery temperatures reach 45°F (+ 5°F), at which time a bimetallic device disengages the overcenter latch allowing the dust covers to close. The SPU dust cover is slaved to the Battery No. 1 dust cover.

In addition to the dust covers, a multi-layer insulation blanket (figure 1-36) is provided to protect the forward chassis components from the space environment and the lunar surface environment. The exterior, and certain portions of the interior, of the multi-layer insulation blanket are covered with a layer of Beta Cloth to protect against wear and tear and direct solar or hot gas heat loads.

LS006-002-2H  
LUNAR ROVING VEHICLE  
OPERATIONS HANDBOOK

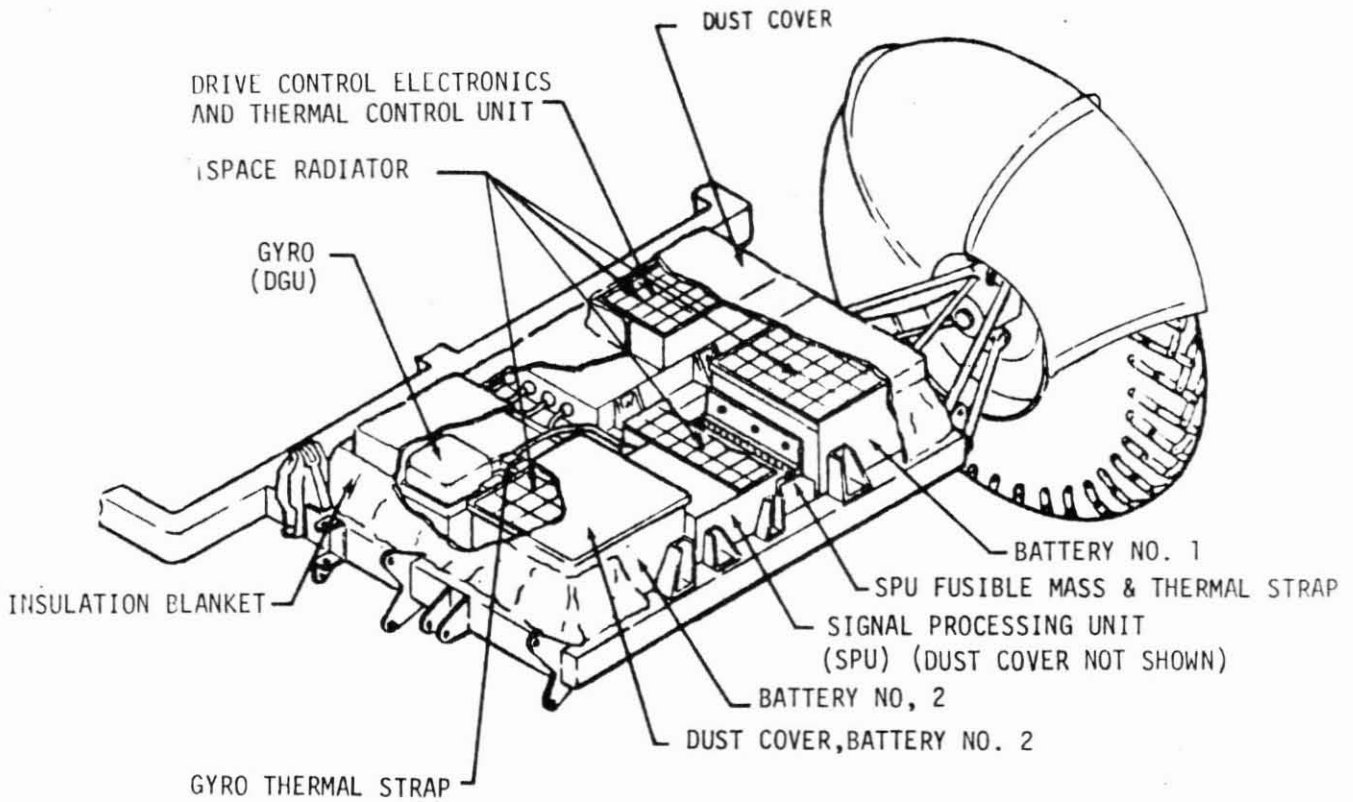

FIGURE 1-31 THERMAL CONTROL PROVISIONS (FORWARD CHASSIS)

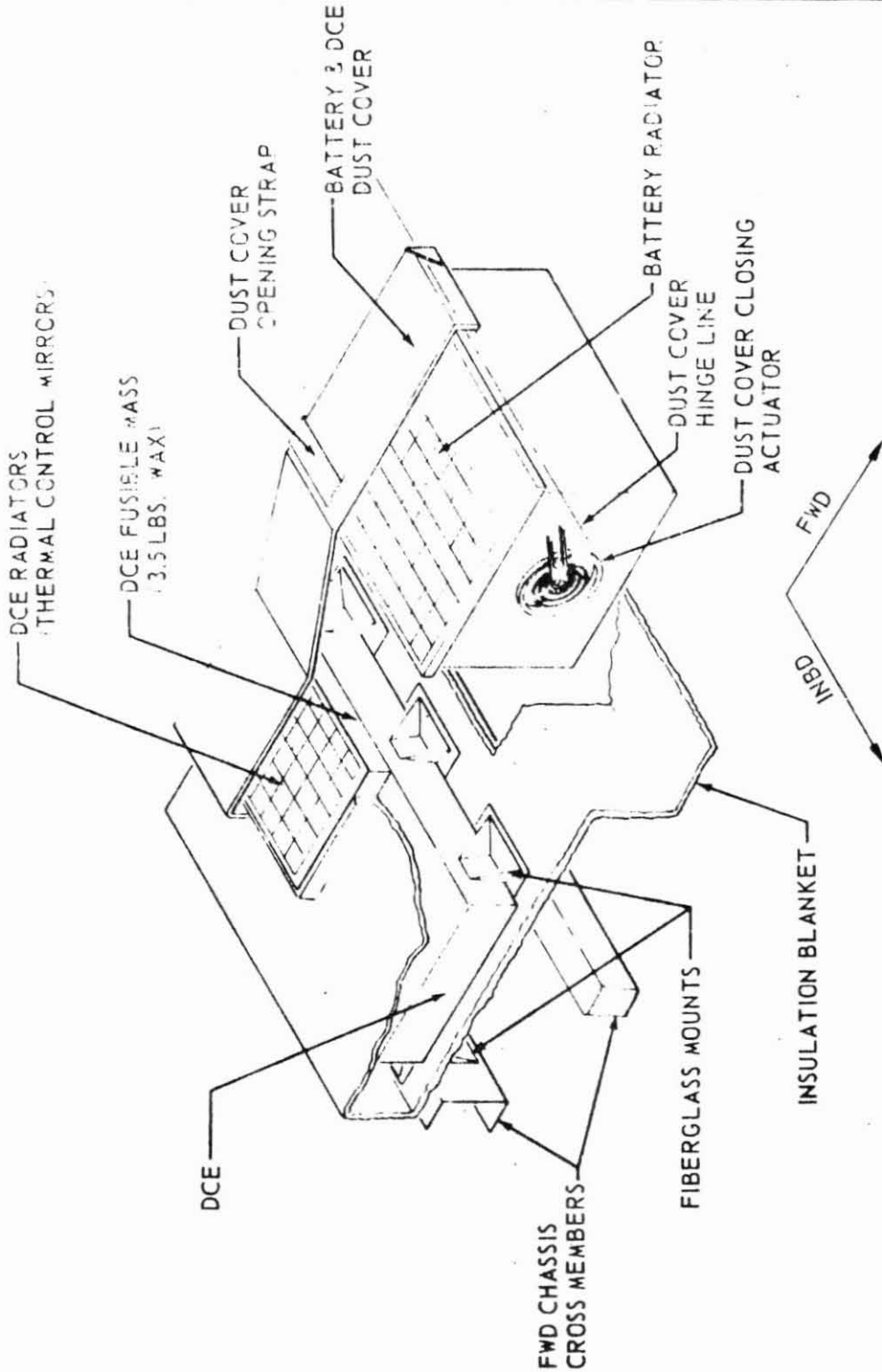

FIGURE 1-32 DRIVE CONTROLLER ELECTRONICS THERMAL CONTROL

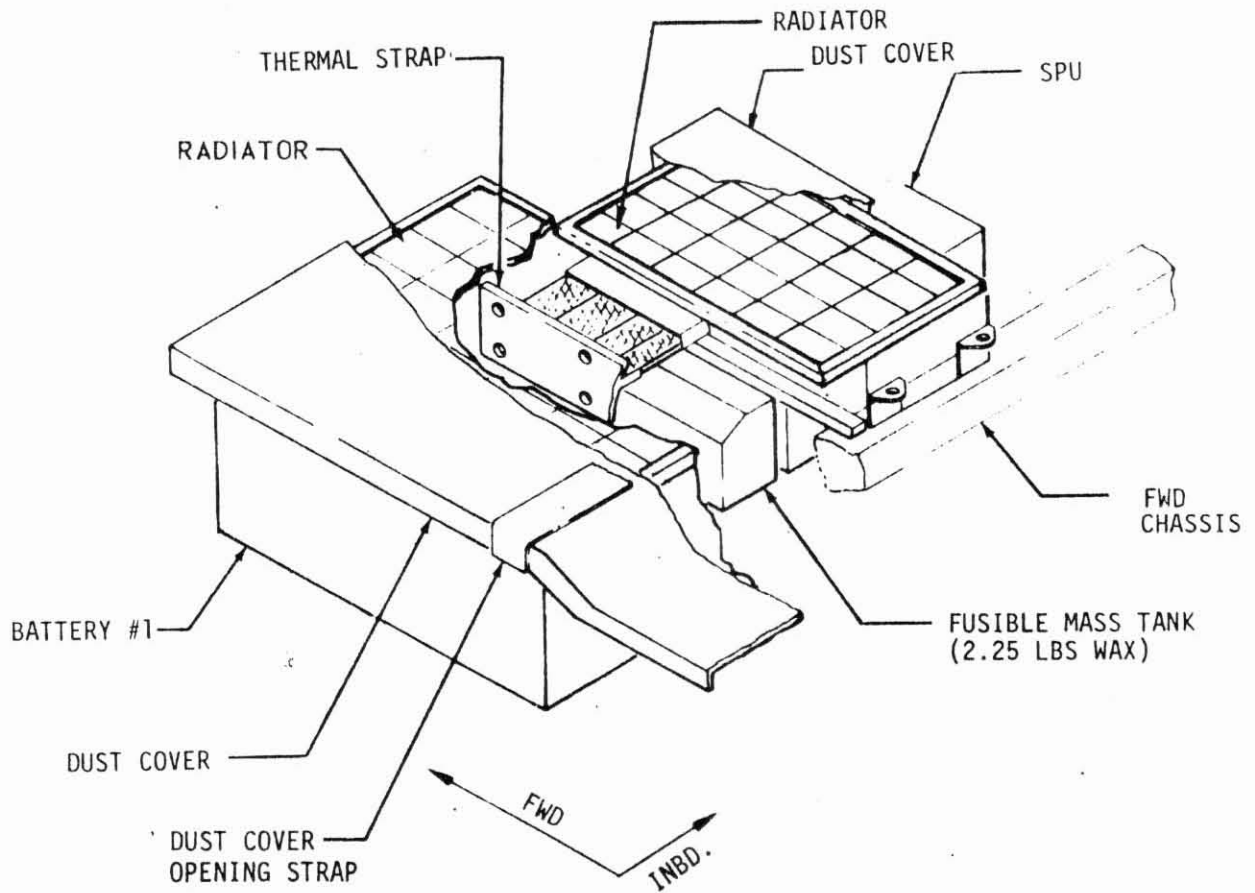

FIGURE 1-33 SPU ELECTRONICS AND BATTERY #1 THERMAL CONTROL

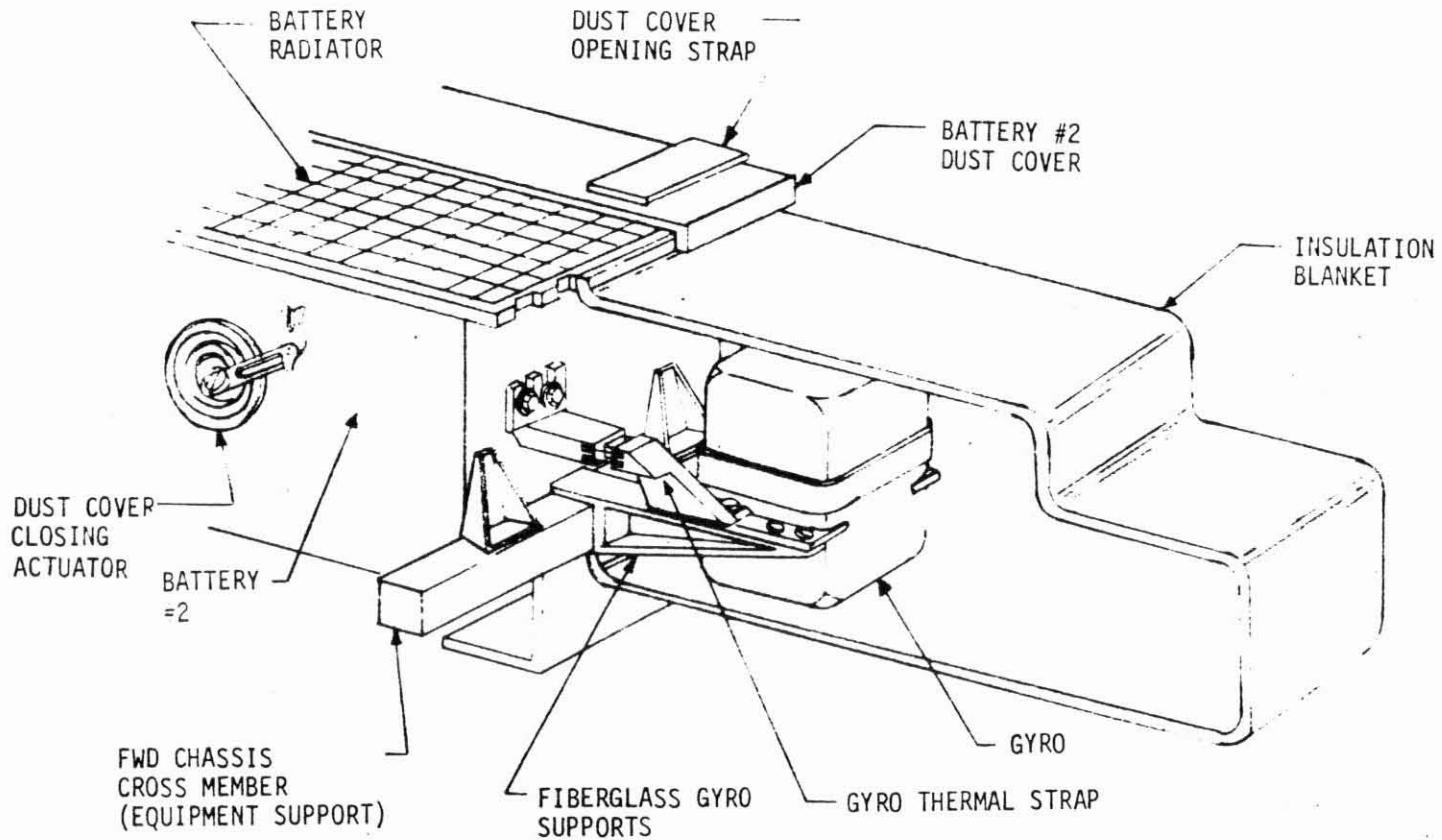

FIGURE 1-34 BATTERY NO. 2 AND DIRECTIONAL GYRO UNIT THERMAL CONTROL



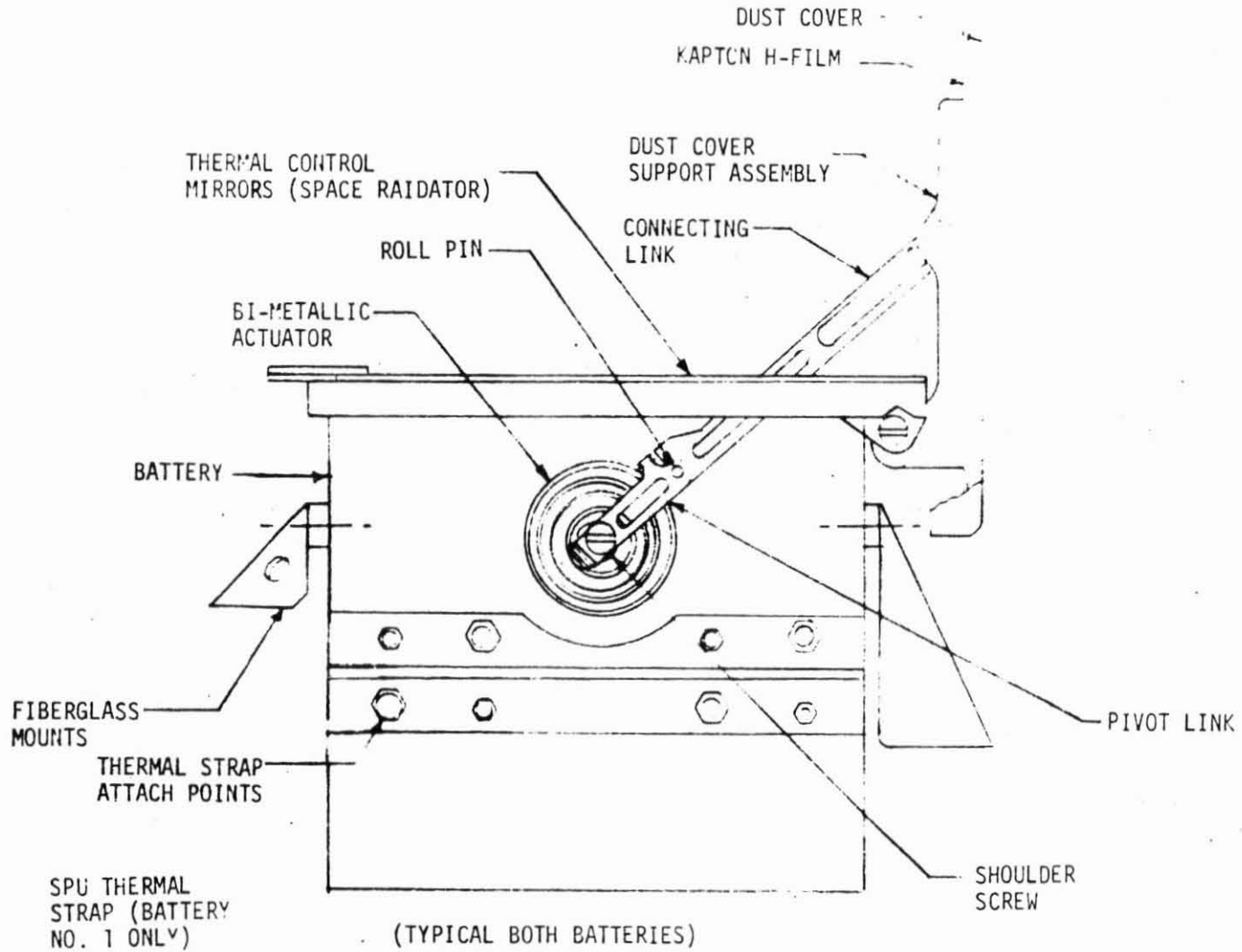

FIGURE 1-35 BATTERY DUST COVER CLOSING MECHANISM

LS006-002-2H  
LUNAR ROVING VEHICLE  
OPERATIONS HANDBOOK

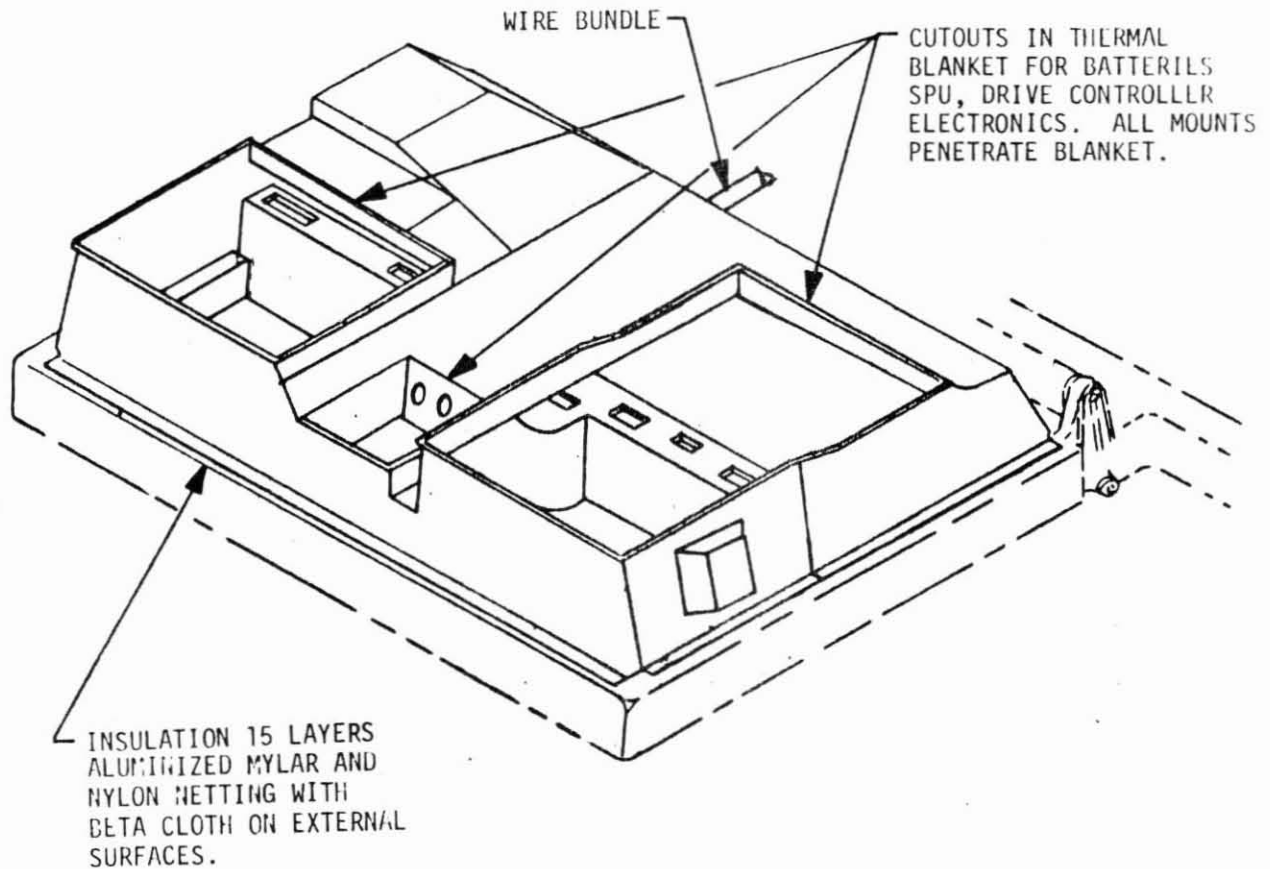

FIGURE 1-36 FORWARD CHASSIS INSULATION BLANKET

1.8.2 (Continued)

During a sortie, the astronauts can monitor the battery temperature by a meter on the Control and Display Console.

1.8.3 Control and Display Console

All instruments on the Control and Display Console are mounted to an aluminum plate which is isolated by radiation shields and fiberglass mounts. The external surfaces of the C&D console are coated with thermal control paint (Dow-Corning 92-007), and the face plate is black anodized and is isolated from the instrument mounting plate.

1.8.4 Center Chassis

Handholds, footrests, tubular sections of seats and center and aft floor panels are anodized.

1.8.5 1G Trainer Thermal Control

Whereas the LRV Flight Unit utilizes radiation to effect thermal control, the 1G Trainer relies primarily on convection to the atmospheric surroundings. The following 1G Trainer elements are cooled by a thermostatically controlled fan blower: traction drive (4 units) electronics assembly, battery (2 units), motor controller assembly (2 units), C&D console, DGU, and SPU. This makes a total of 12 separate blowers on the vehicle. Each fan motor thermostatic switch closes upon a rising temperature at a predetermined value, thereby applying battery voltage to a fan motor. When the temperature of the thermostat falls below a predetermined value, the switch opens, thereby shutting the fan motor off. Cooling fan motors and instrumentation warning thermostats are set as noted in Table 1-2.

NOTE

The forward wheel traction drive fan blowers are enabled provided that there is power through at least one forward drive power switch. Similarly, the rear wheel traction drive fan blowers are enabled provided there is power through at least one rear drive power switch.

In addition to protective cooling, thermal instrumentation display at the C&D is provided for the traction drives and batteries. The display takes the form either of a discrete warning by a warning flag (activated by a thermostat) or an analog temperature display, (as sensed by a thermistor). Warning flag thermostats are located on the external motor case of each traction drive motor, on the external case of each traction drive gear reducer, and within each battery assembly. Thermostats are set as noted in Table 1-2. Note that a warning flag activation can be generated in a traction drive assembly by

LS006-002-2H  
LUNAR ROVING VEHICLE  
OPERATIONS HANDBOOK

| <u>COOLING FAN MOTOR THERMOSTATS SET AT:</u> |                           |                          |
|--|---------------------------|--------------------------|
| <u>Sub Assembly</u>                          | <u>Close On Rise Temp</u> | <u>Open On Fall Temp</u> |
| Traction Drive Motor (4 units)               | 160 ± 10°F                | 140 ± 10°F               |
| Electronics Assembly (1 unit)                | 100 ± 5°F                 | 85 ± 5°F                 |
| Battery (2 units)                            | 100 ± 5 °F                | 85 ± 5°F                 |
| Motor Controller Assembly (2 units)          | 100 ± 5°F                 | 85 ± 5°F                 |
| Display & Control Console (1 unit)           | 120 ± 3°F                 | 114 ± 3°F                |
| Navigation SPU                               | 120 ± 3°F                 | 114 ± 3°F                |
| Navigation DGU                               | 150 ± 5°F                 | 140 ± 5°F                |

| <u>WARNING FLAG THERMOSTATS SET AT:</u> |                           |                          |
|---|---------------------------|--------------------------|
| <u>Sub Assembly</u>                     | <u>Close On Rise Temp</u> | <u>Open On Fall Temp</u> |
| Traction Drive Motor (4 units)          | 225 ± 5°F                 | 175 ± 10°F               |
| Traction Drive Gear Reducer (4 units)   | 200 ± 5°F                 | 150 ± 10°F               |
| Battery (2 units)                       | 160 ± 5°F                 | 120 ± 5°F                |

| <u>ANALOG DISPLAY THERMISTORS RESISTANCE VALUES ARE:</u> |                        |                        |
|--|------------------------|------------------------|
| Traction Drive Motor (4 units) Thermistor                | 3750 ohms + 10% @ 80°F | 315 ohms ± 20% @ 225°F |
| Battery (2 units) Thermistor                             | 553 ohms + 5% @ 80°F   | 640 ohms + 5% @ 160°F  |

TABLE 1-2 1G TRAINER THERMAL CONTROL DEVICE SET POINTS

LS006-002-2H  
LUNAR ROVING VEHICLE  
OPERATIONS HANDBOOK

---

1.8.5

(Continued)

either the drive motor or the gear reducer assembly. Since only the drive motor has its temperature displayed on the console meters, a condition could arise where a "hot" gear reducer activated the warning flag but none of the temperature indicating meters show an abnormally high temperature, i.e., the drive motor associated with the hot gear reducer has a normal temperature. Under this condition it would be impossible for the operator to isolate the over-temperature to a specific subassembly. To alleviate this condition, the gear reducer warning thermostat is connected through a circuit such that whenever it closes it switches a low resistance across the associated drive motor thermistor; thereby, causing an abnormally high temperature reading to be displayed. Thus, the affected traction drive assembly can be isolated.

Analog temperature thermistors are located on the external case of each drive motor and on the main battery bus within each battery. Thermistors located in each assembly are monitored by a bridge circuit in the D&C console and the output of the bridge drives the display meters, which are calibrated in degrees Fahrenheit. By interrogating the temperature display meters, an overtemperature condition can be isolated to the specific subassembly and corrective action initiated. The nominal resistance values associated with both an ambient temperature and a "hot" temperature for these thermistors is noted in Table 1-2. It should be noted that only the battery readout meter is calibrated to indicate the thermistor temperature. The drive motor meters are calibrated to read the internal motor (rotor) temperature even though the thermistor is located external on the motor case and hence at much cooler location. Thus, the meter indicated temperature for each motor will be 450°F to 500°F when the thermistor is measuring an actual case temperature of 225°F. The cooling fan motors will activate when the meter indicated temperature is nominally 350°F.

## 1.9 SPACE SUPPORT EQUIPMENT (SSE)

The Space Support Equipment (SSE) consists of two basic subsystems of hardware, the structural support subsystem and the deployment hardware subsystem. The function of the structural support subsystem is to structurally support the LRV in the LM during launch boost, earth-lunar transit and landing. The function of the deployment hardware subsystem is to deploy the LRV from the LM to the lunar surface after landing.

### 1.9.1 Structural Support Description

The structural support subsystem by which the LRV is attached to the LM includes two steel support spools at the lower (left and right) sides of the LM quadrant. The spools are bolted to Grumman Aircraft Corporation (GAC) attach fittings. Aluminum tube tripod structures attached to the LRV center chassis terminate in apex fittings which steel are pinned together and clamped to the spools to support the LRV. The LRV is restrained against outboard rotation by an aluminum strut in the upper center of the LM, connecting the inboard quadrant corner structure to an LRV center chassis standoff with a pin.

### 1.9.2 Deployment Hardware Description

The deployment hardware system (figure 1-37) consists of bellcranks, linkages and pins to release the LRV from the structural support subsystem, thus allowing the LRV to deploy from the LM. It also consists of braked reels, braked reel operating tapes, braked reel cables, LRV rotation initiating push-off spring, deployment cable, telescopic tubes, chassis latches, release pin mechanisms, and LRV rotation support points.

### 1.9.3 Deployment Mechanism Operations

The LRV is attached to the SSE and deployment mechanism and held in position in the LM Quadrant as shown in figure 1-38. The deployment of the LRV from the LM to the lunar surface consists of five basic steps or phases:

- Phase I - Deployment from the stowed position of both braked reel separating tapes and the deployment cable (figure 1-39, inset (A) )
- Phase II - Operating the D-Handle to disconnect the LRV from the structural support subsystem (figure 1-39, inset (A) ).
- Phase III - Operating the double braked reel to unfold the LRV and lower the aft chassis wheels to the lunar surface (figure 1-39, insets (B), (C) and (D) ).

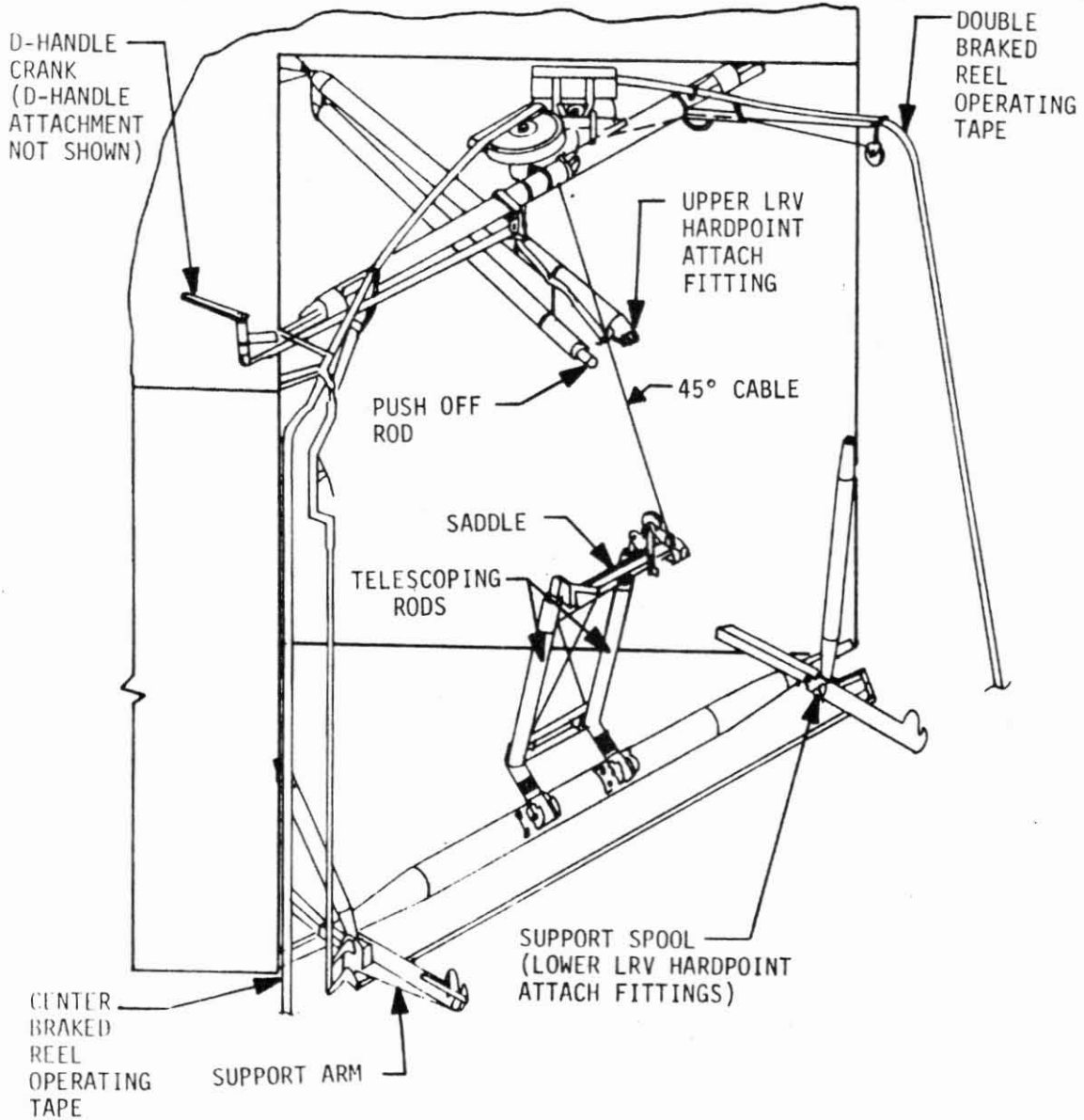

FIGURE 1-37 SPACE SUPPORT EQUIPMENT

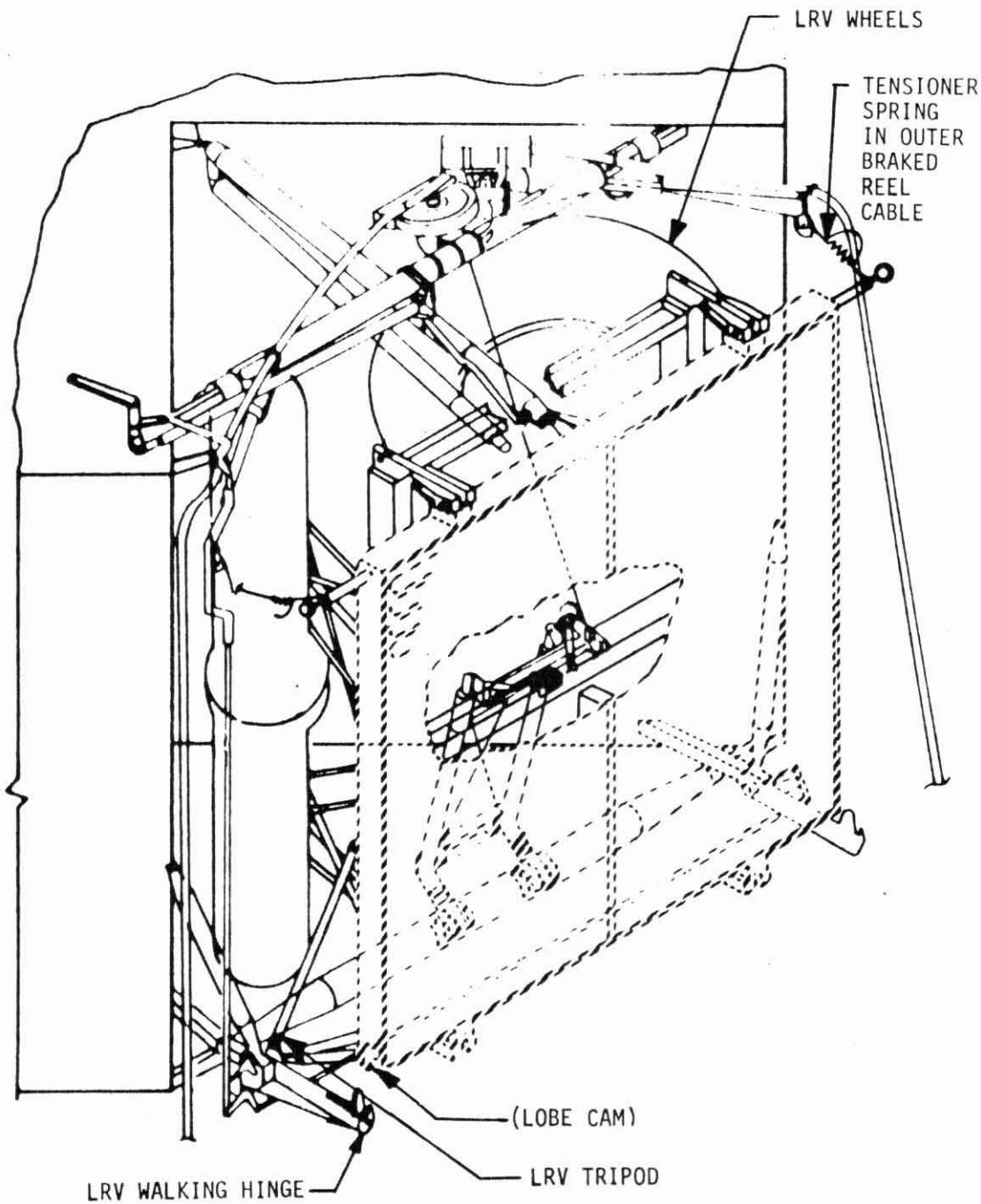

FIGURE 1-38 LM/SSE WITH LRV INSTALLED



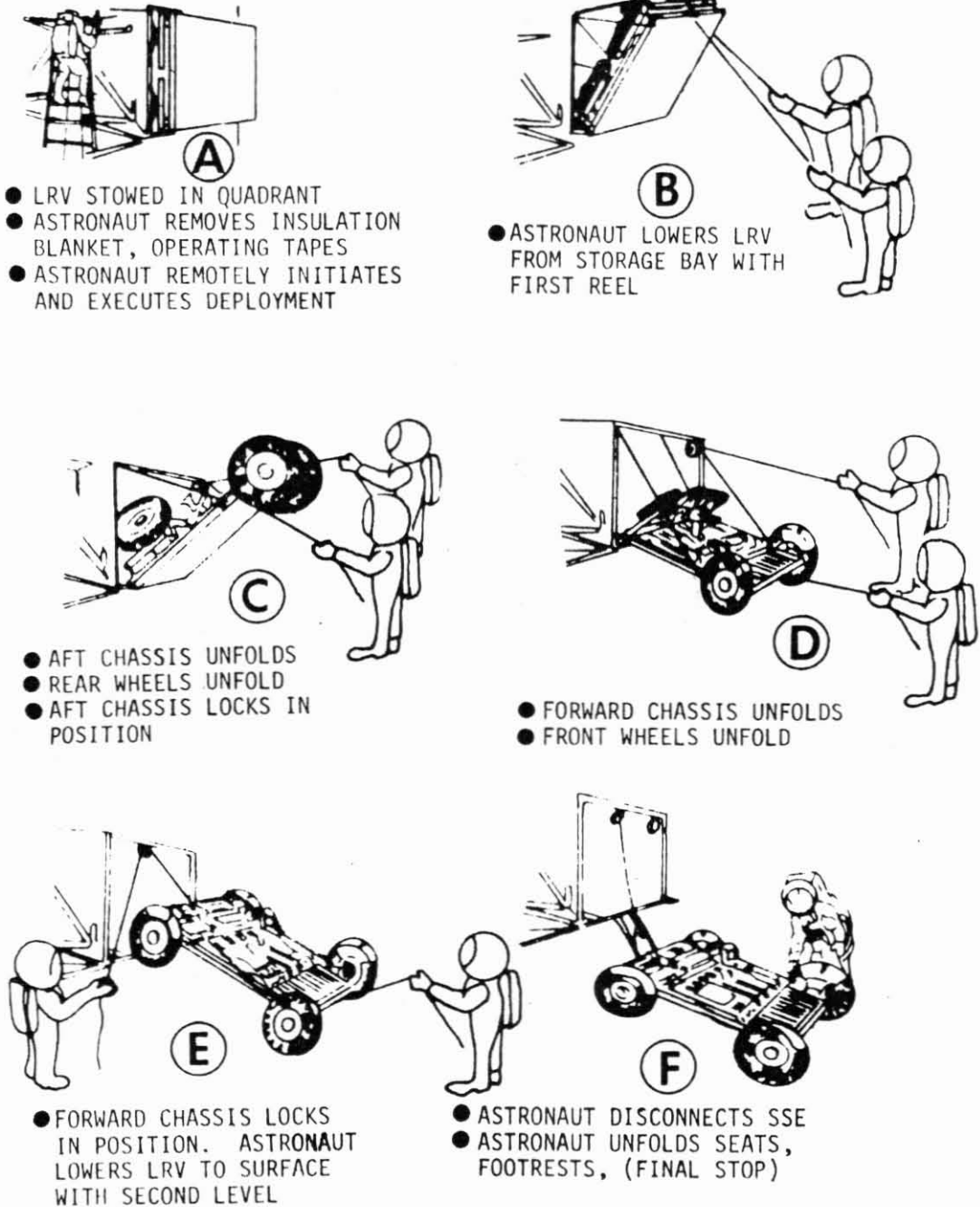

FIGURE 1-39 LRV DEPLOYMENT SEQUENCE

LS006-002-2H  
LUNAR ROVING VEHICLE  
OPERATIONS HANDBOOK

---

1.9.3 (Continued)

Phase IV - Operating the center braked reel to lower the forward chassis wheels to the lunar surface (figure 1-39, inset (E) ).

Phase V - Disconnecting the SSE from the LRV after all four wheels are on the surface (figure 1-39, inset (F) ).

1.9.3.1 Phase I Deployment Description

This phase consists of visual inspection, removal of insulation blanket (figure 1-40), deployment of the two braked reel operating tapes and the deployment cable from their stowed position. The double braked reel operating tape is stowed in a nylon bag attached to the lower, right support arm by velcro tape. The center braked reel operating tape is stowed on the left side of the LRV center chassis by velcro tape in a nylon bag attached to the lower left support arm by velcro tape (figure 1-41). The deployment cable is stowed on the left side of the LRV center chassis by teflon clips. The deployment cable is used to assist deployment of the LRV in the eventuality that the LRV stops during any phase of the deployment.

1.9.3.2 Phase II Deployment Description

At the completion of Phase I, the astronaut actuates the D-handle, which is located on the right side of the porch (figure 1-42). The first 5 to 6 inches of travel of the D-handle removes the two lower release pins (figure 1-43) out of the apex fittings, releasing the lower half of the apex fittings, allowing it to fall away immediately or during deployment rotation. The apex fittings are now configured to lift off of the spools when required. The last segment of travel of the D-handle removes the upper release pin. When the upper release pin is removed, the push-off spring rotates the LRV out from the LM approximately 4°, taking up the slack in the outer braked reel cables. The slack is due to cable tensioner springs in the cables.

1.9.3.3 Phase III Deployment Description

The LRV is now released from the LM and is ready to be deployed to the lunar surface. During the entire Phase III operations, the astronaut operates the double braked reel operating tape. The braked reel (figure 1-44) is a worm and worm gear arrangement. When the operating tape is pulled, the cable storage drum is rotated, thus releasing (feeding off) cable from the drum. The cable is attached to the LRV center chassis and, as the LRV rotates out-board due to gravity, supports the LRV. As the drum is rotated, feeding out cable, the LRV is allowed to rotate and deploy. For the first 15° of rotation, the LRV rotates on the apex fittings. At 15° rotation, the walking hinge is engaged by the LRV and the point of rotation shifts from the apex fittings to the walking hinge, at which point the apex fitting lifts off of the spools. The deployment cable may or may not be required at this time, depending on the landed attitude of the LM.

Mission J Basic Date 12/4/70 Change Date 4/19/71 Page 1-69

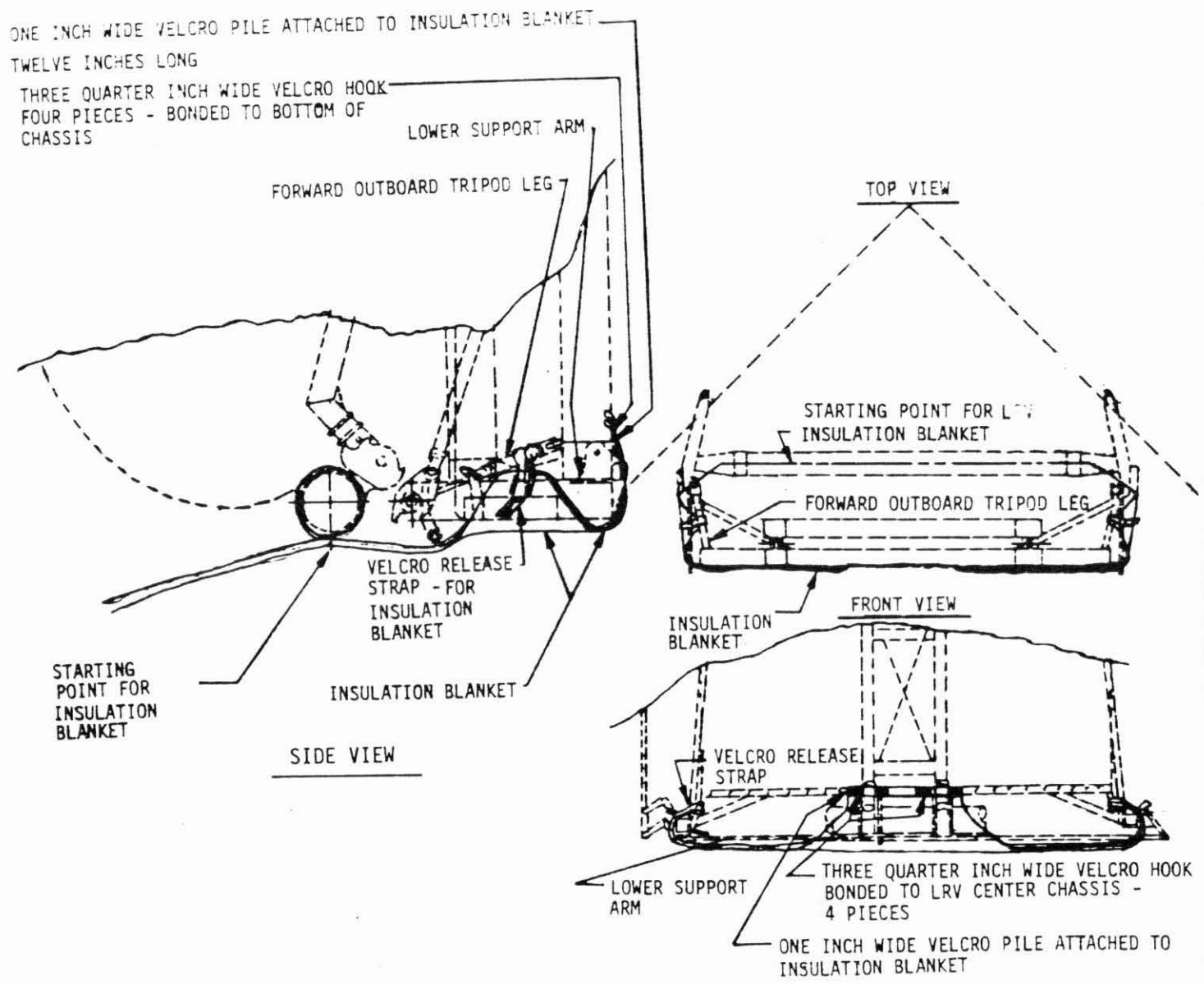

LS006-002-2H  
LUNAR ROVING VEHICLE  
OPERATIONS HANDBOOK

FIGURE 1-40 INSULATION BLANKET

NOTE: DOUBLE BRAKED REEL  
DEPLOYMENT TAPE SIMILAR  
TO CENTER BRAKED REEL  
TAPE BUT STOWED ON  
RIGHT SIDE OF VEHICLE

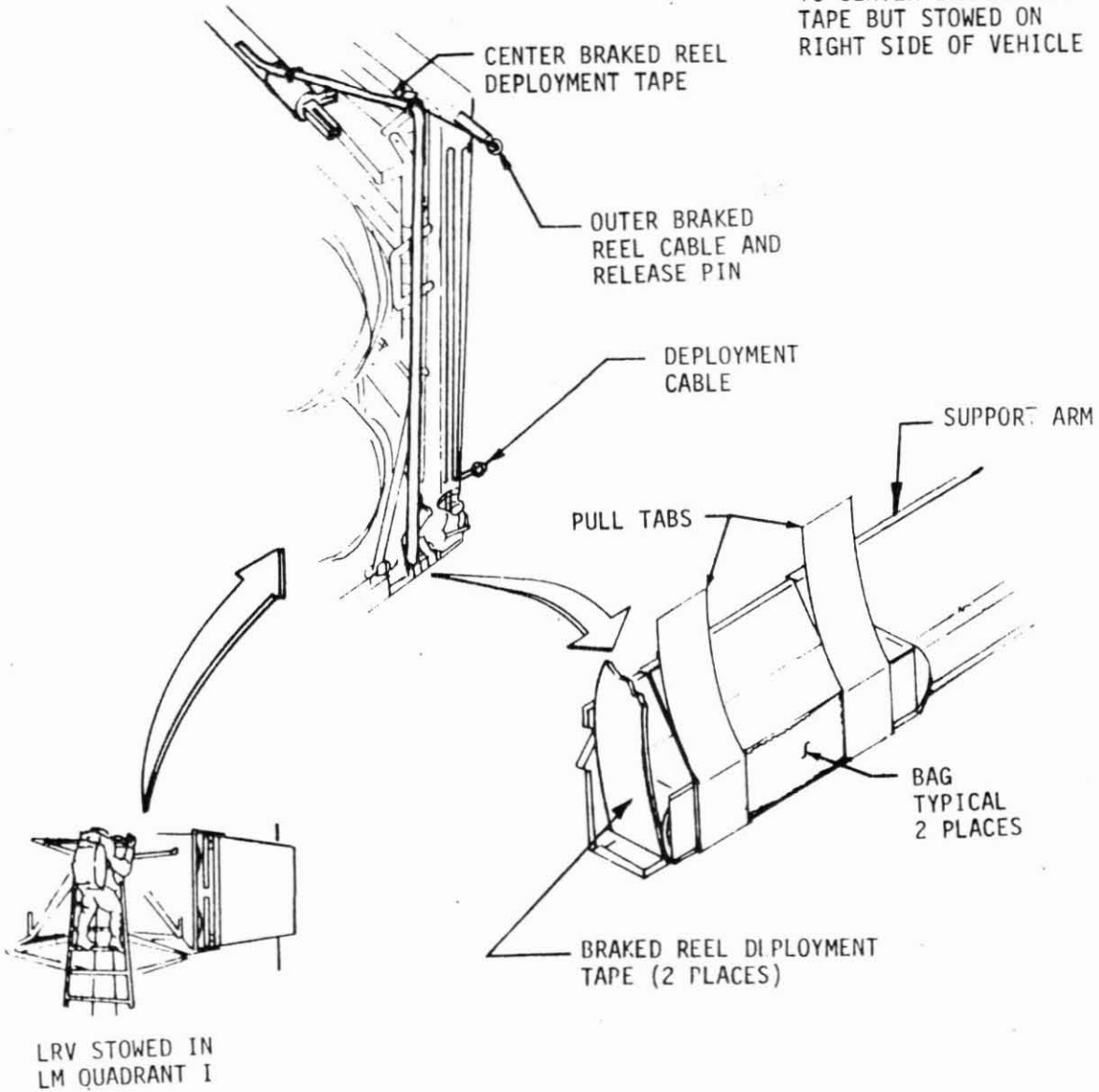

FIGURE 1-41 LRV DEPLOYMENT TAPES AND CABLES

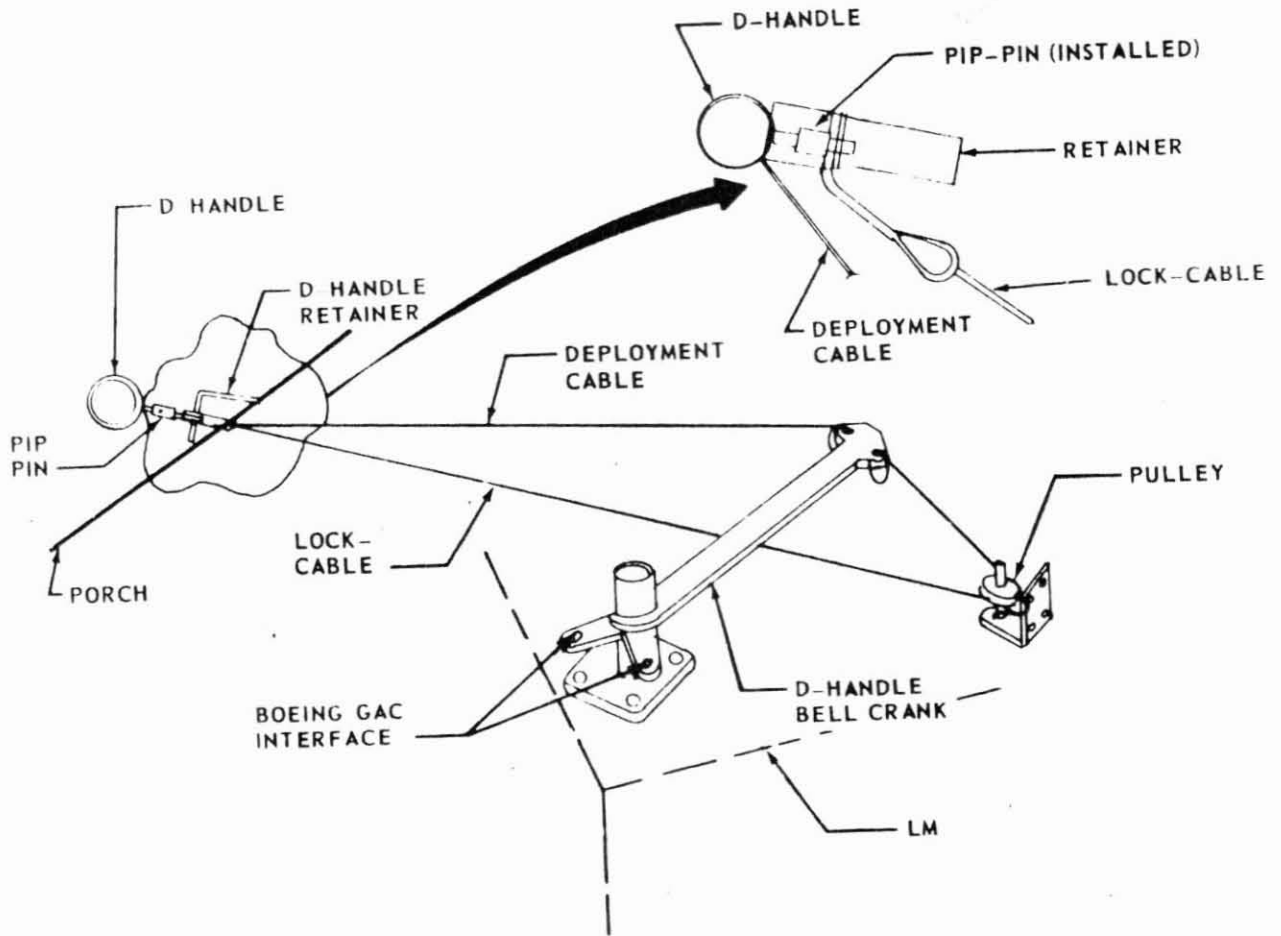

FIGURE 1-42 D-HANDLE RELEASE SYSTEM

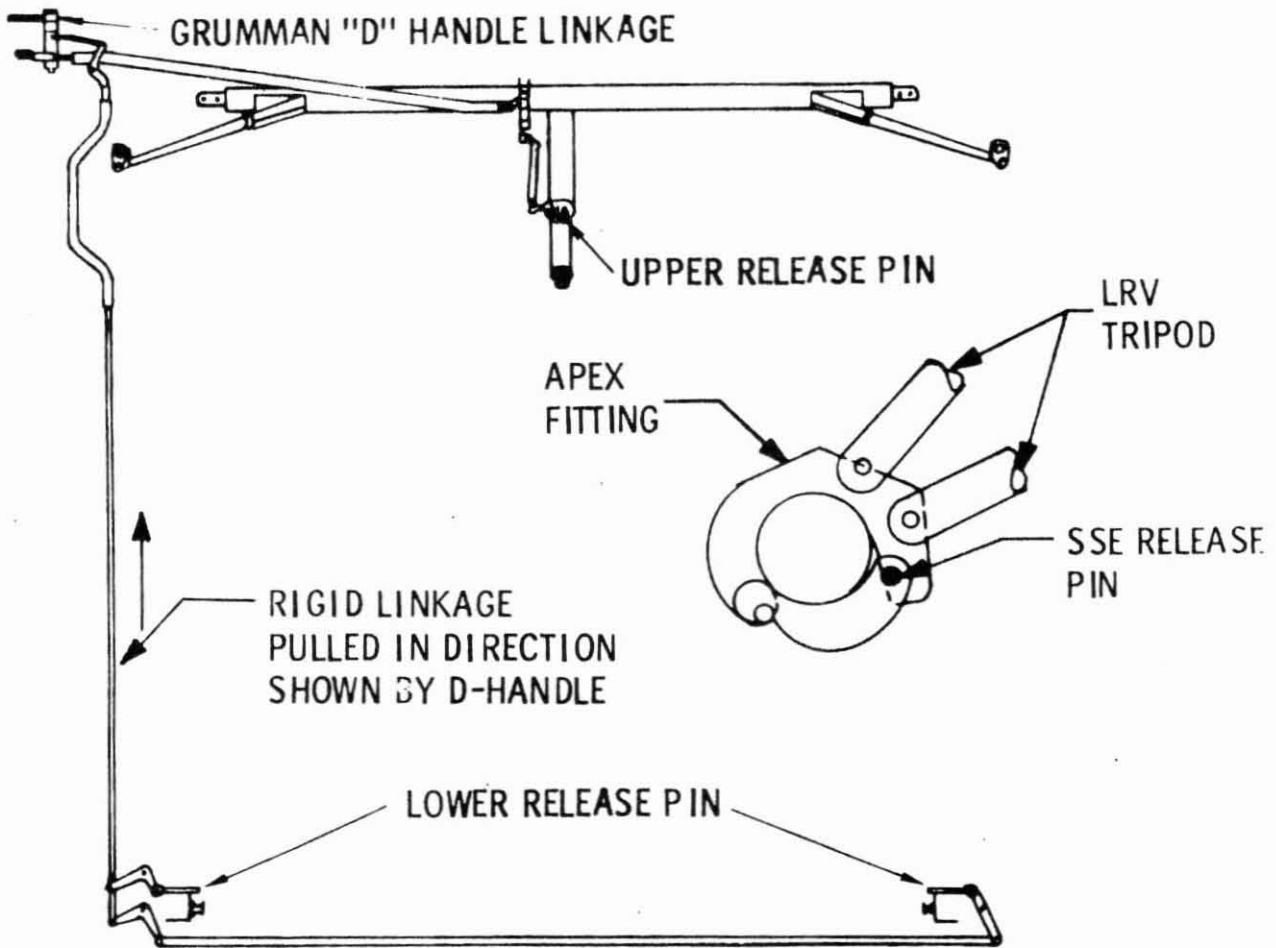

FIGURE 1-43 LRV/SSL SUPPORT STRUCTURE AND RELEASE SYSTEM

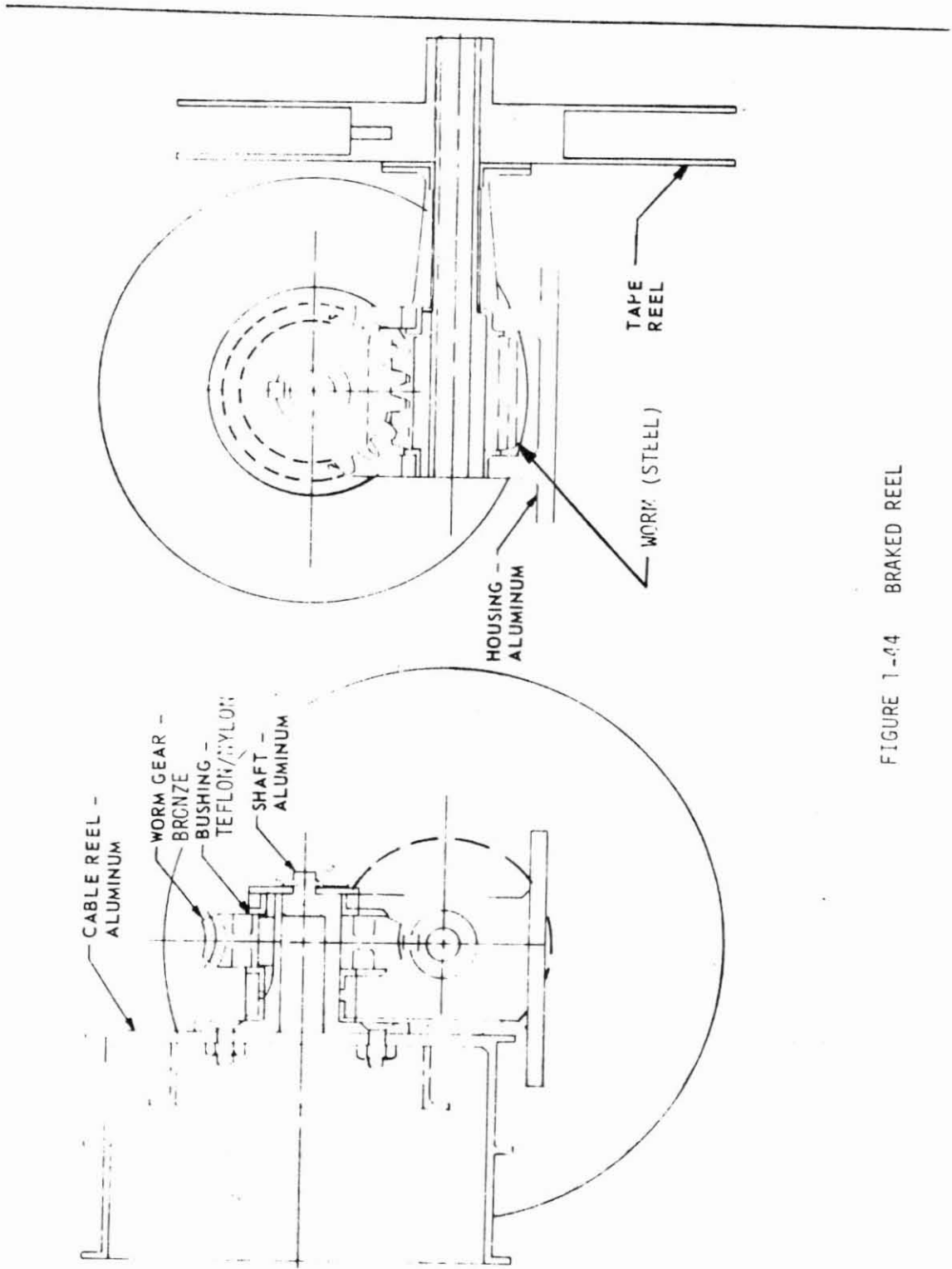

FIGURE 1-44 BRAKED REEL

1.9.3.3 (Continued)

The LRV continues to rotate about the walking hinge. At 35° rotation, the lower telescopic tubes ratchets are engaged, preventing any reverse rotation of the telescopic tube assembly about its lower pivot points. The telescopic tube assembly consists of a pair of three telescoped aluminum tubes, hinged to the GAC structure (lower center of the LM quadrant) and connected at the top by the saddle (figure 1-44). The aluminum saddle fits to the forward section of the forward chassis, held by two dowel pins and a ball-lock pin clevis joint. The saddle carries the pulleys, cables and pin mechanisms whereby the forward and aft LRV chassis are unlocked from the stowed (folded) LRV position. As the LRV moves outboard, the 45° cable tightens, and rotates each with a steel cable and ball-lock pin. The two ball-lock pins lock the connection between forward and aft chassis to the console post mounted on the center chassis (figure 1-45). If either the aft chassis latch pins or the forward chassis latch pin fails to pull, the deployment cable may be pulled to accomplish this action. (The mechanical advantage of the deployment cable to the pins themselves is 5 to 1).

The telescopic tubes and forward chassis stops at 45° due to the 45° cable (chassis latch actuating cable) becoming taut, then by counteracting forces of the LRV forward chassis hinge torsion spring, the telescopic tubes and forward chassis return to the 35° position (stop due to the telescopic tube ratchet). The center chassis and aft chassis continue to deploy. After it is unlocked, the aft chassis fully deploys (unfolds) due to the aft chassis hinge torque bars, until it latches with the center chassis.

The wire mesh LRV wheels are held in the stowed position by four aluminum tube struts. One end of each strut is held by a steel pin to the aft or forward chassis structure (figure 1-46). The other end of each strut is held to a wheel hub by a pin (in the hub). The pins in the chassis are pulled by a steel cable, so linked as to pull the pins as the chassis opens, approximately 170°. When the pins are pulled, the spring-loaded wheels move to deployed or operational position. As the wheels rotate forward to the deployed position, a mechanism within the wheel hub retracts the remaining pin retaining the wheel strut. The strut is thus freed at both ends, and falls free during wheel deployment movement. Each strut is retained by a 1/8 inch diameter mylar tether.

The LRV center/aft chassis continues outboard rotation, pivoting around the lower support arm latch. During LRV outboard rotation, the telescopic tubes extend (lengthen). Before 72° LRV rotation an anti-collapse telescopic tube latch in each tube engages to prevent shortening (but permit elongation) of the tubes.

At approximately 73° center chassis angle, the lobe (cam) on the forward sides of the center chassis strut (engaged in the lower support arm latch) strikes the steel latch lock arm. As the chassis rotates, the cam forces the latch lock arm down out of a safety retaining spring, and unlocks the latch. The center/aft chassis continues to rotate until the aft chassis wheels



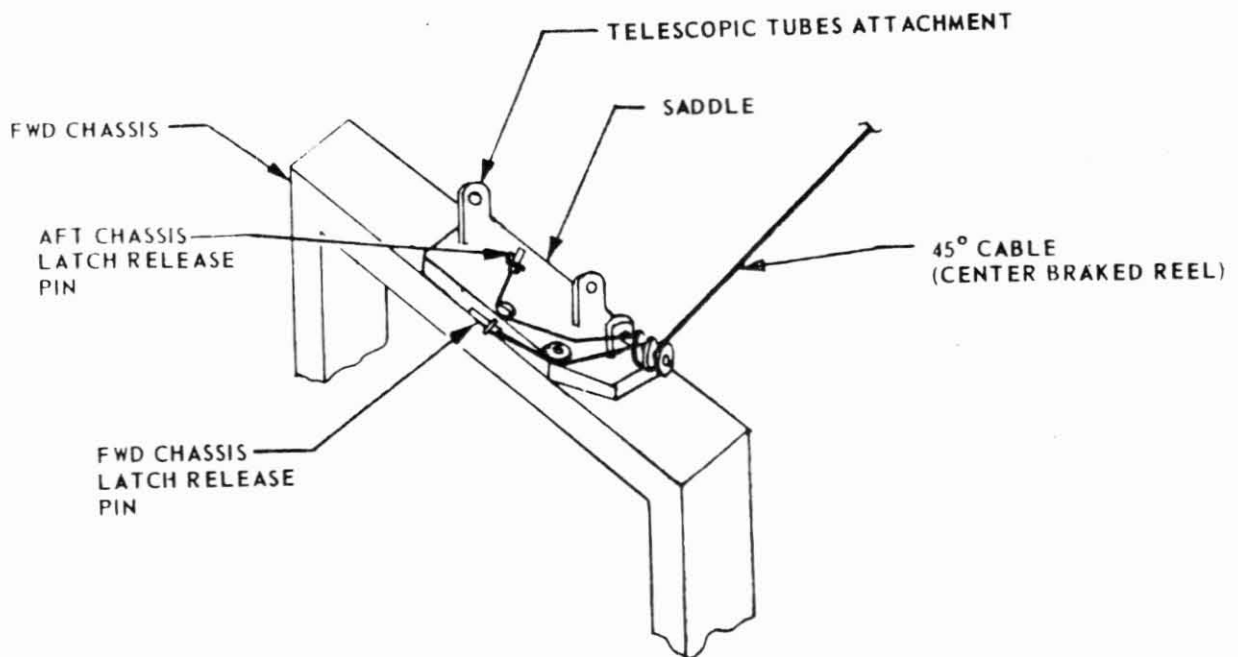
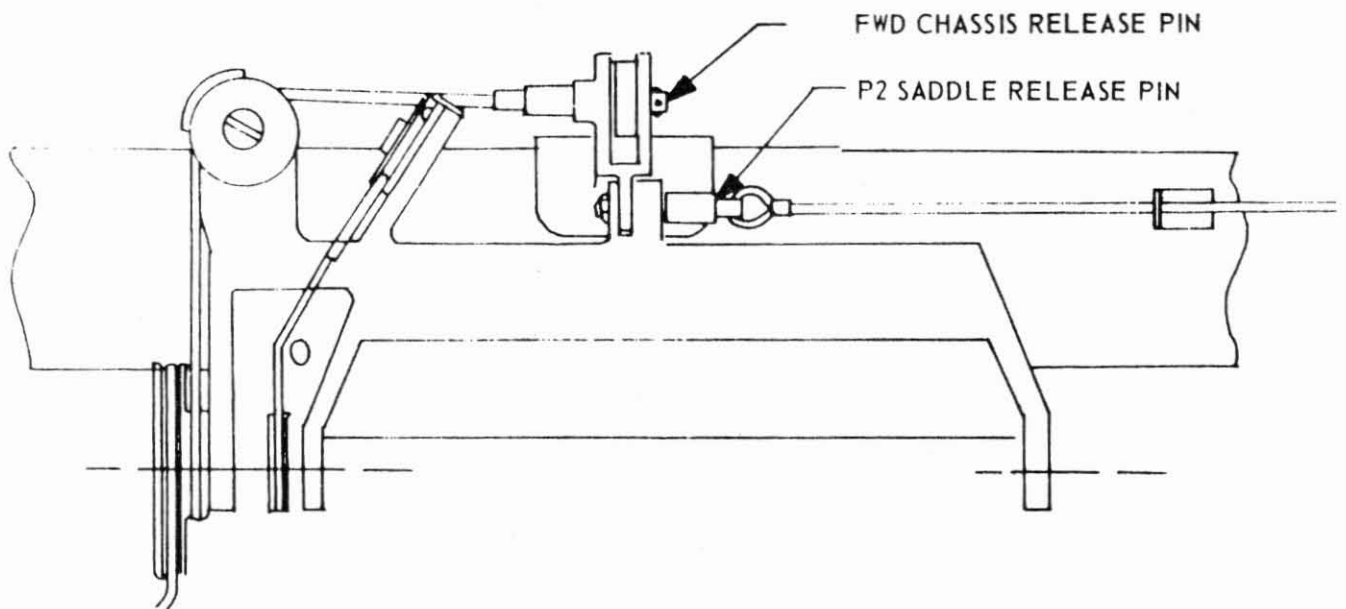

FIGURE 1-45 LRV SADDLE AND FORWARD CHASSIS LATCH RELEASE

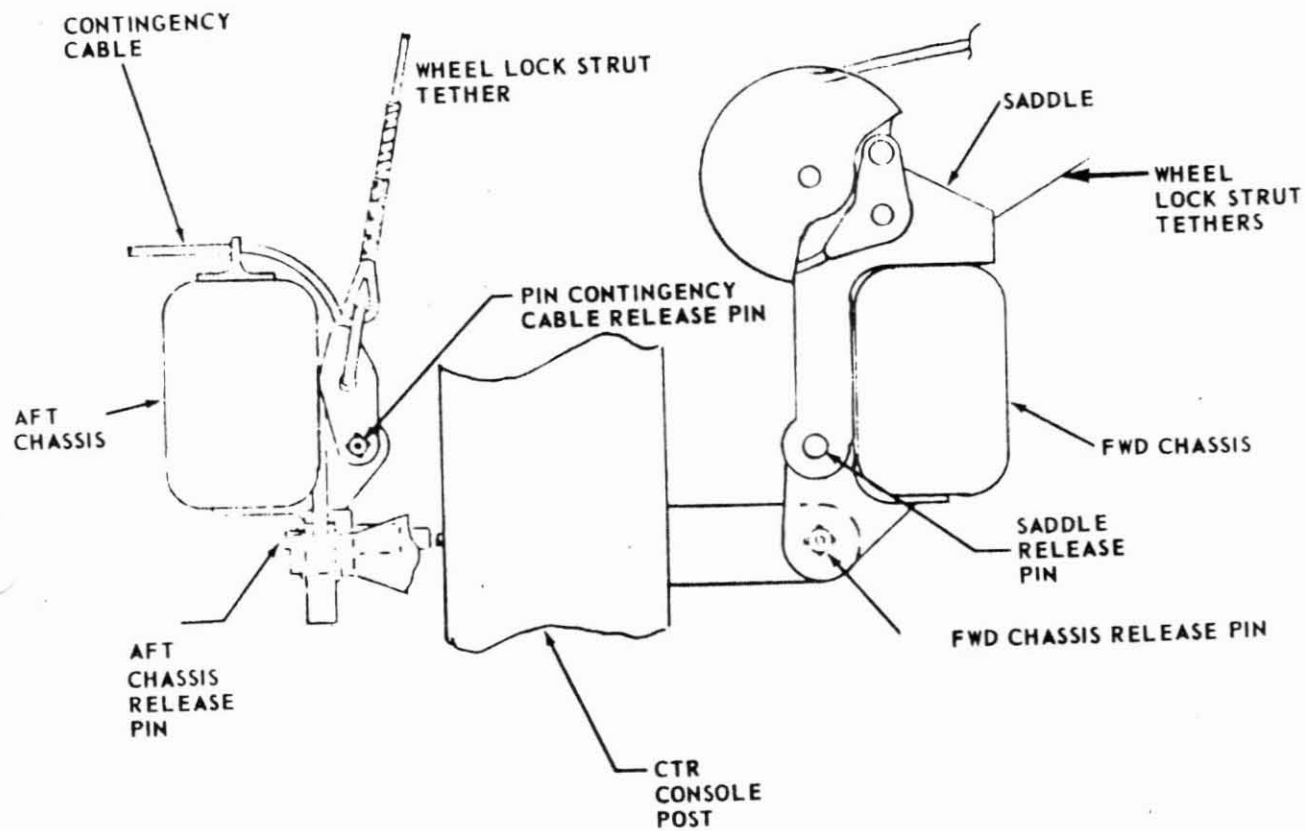

FIGURE 1-46 FORWARD AND REAR CHASSIS LATCH

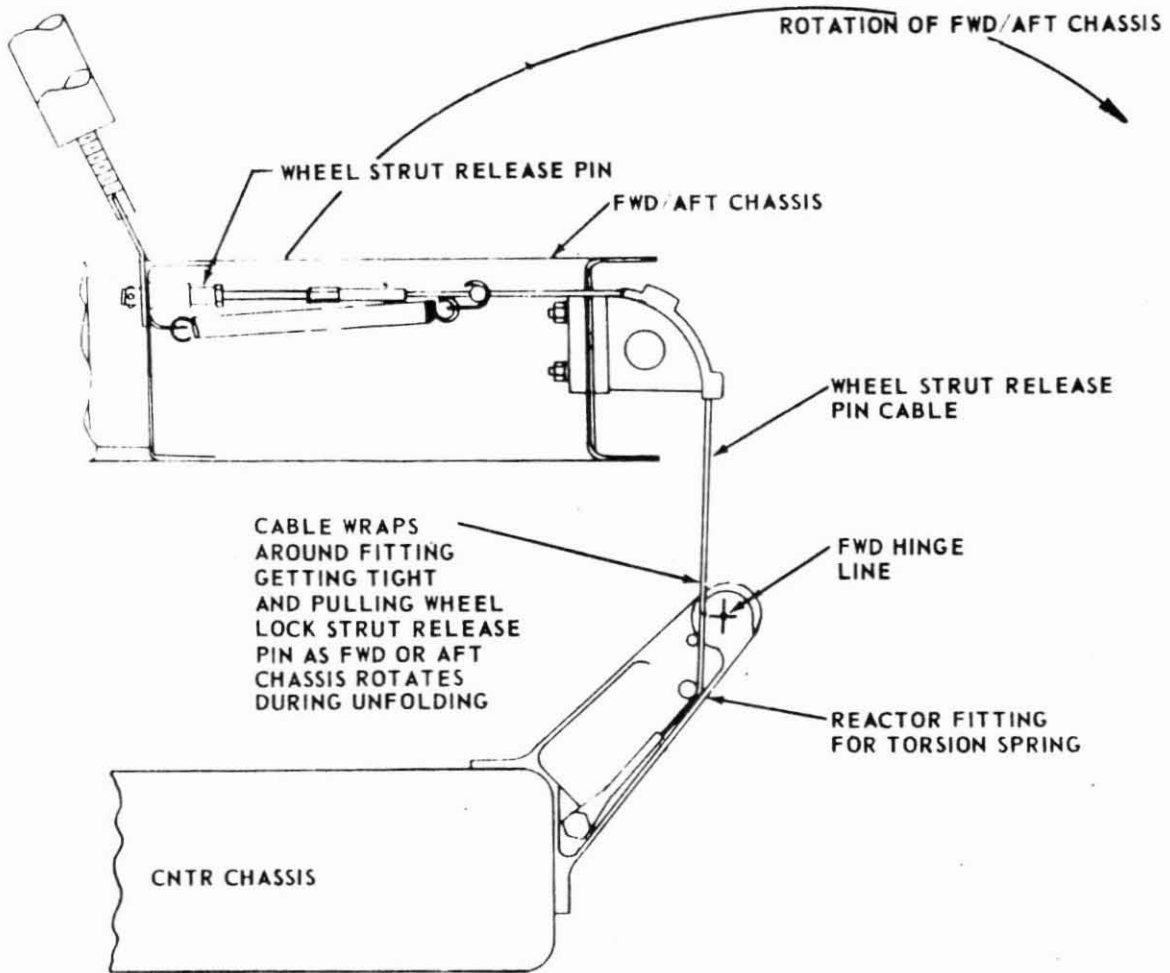

FIGURE 1-47 WHEEL LOCK STRUT RELEASE

LS006-002-2H  
LUNAR ROVING VEHICLE  
OPERATIONS HANDBOOK

---

1.9.3.3 (Continued)

are on the surface. The wheels are locked with the emergency hand brake, therefore must slide on the surface. Depending on the landing attitude of the LM and the condition of the surface, the wheels might not slide on the lunar surface, therefore use of the deployment cable by the astronaut would be required. The astronaut continues to actuate the double braked reel operating cable to allow the forward chassis hinge to deploy by virtue of the forward chassis hinge torsion spring. Concurrently, the center/aft chassis move outboard, away from the LM. At this point in the sequence, the 45° cable becomes taut due to the outboard movement of the entire LRV. The center chassis continues to move down and, driven by the forward chassis springs, outboard. As the angle between forward and center chassis approaches 170°, the forward wheel lock strut pins in the forward chassis release, and the forward wheels deploy like the previously described aft wheel deployment. The astronaut then pulls the pins that attach the two outer braked reel cables to the center chassis.

Phase III is complete (motion ceases) with the aft wheels on the lunar surface, with forward and aft chassis locked to the center chassis, all wheels deployed, all four wheel struts free and hanging from their tethers, the outer braked reel cables released, and with the forward chassis held up by the telescopic tube assembly and the 45° cable.

1.9.3.4 Phase IV Deployment Description

This phase of the deployment consists of the astronaut actuating the center braked reel operating tape, thus allowing the forward chassis to lower and the forward chassis wheels to lower to the surface. Again, the deployment cable may be required at this point if the aft wheels will not slide on the surface.

1.9.3.5 Phase V Deployment Description

This phase consists of releasing the deployment hardware from the LRV. The astronaut pulls up on the saddle release cable, located on the left rear side of the forward chassis. This operation releases a ball-lock pin which holds the saddle on the forward chassis. When the saddle is released, the following hardware goes with it:

- a. Telescopic tube assembly.
- b. Forward and aft chassis lock release pins.
- c. Forward chassis wheel lock struts and tethers.

The astronaut then pulls a ball lock pin, located on the aft center of the aft chassis. This releases the deployment cable and the aft chassis wheel lock struts. At this point, the deployment from the LM to the lunar surface is complete.

LS006-002-2H  
LUNAR ROVING VEHICLE  
OPERATIONS HANDBOOK

---

SECTION 2  
NORMAL PROCEDURES

INTRODUCTION

This section defines the normal procedures to be followed by the astronauts for operating the LRV on the lunar surface and the 1G Trainer during earth training operations.

\*\*\* 1G TRAINER NOTE \*\*\*

The procedures contained in this section also apply to 1G Trainer operation with the exception of deployment operations, defined in 2.1. When performing training per paragraph 2.1 all steps can be performed except those dealing with pulling the LM D-rings, inspecting hinge pins, and deploying the inboard handholds.

Mission 3 Basic Date 12/4/70 Change Date 4/19/71 Page 2-2

| STA/STEP | PROCEDURE  | REMARKS  |
|----------|--|--|
| 2.1      | <p style="text-align: center;">UNLOADING AND CHASSTS DEPLOYMENT</p> <p>Both crewmen are utilized. Procedure steps are for one crewman unless otherwise noted.</p> <p>a. Perform an overall inspection of the LRV and SSE to verify proper configuration and no obvious damage.</p> <p>b. Release LRV insulation blanket.</p> <p>c. Inspect each of two lower support arm latches to verify proper configuration. Latch should be in position and trip arm should be up. Apply force to latch to verify support.</p> <p style="padding-left: 20px;">If either latch is in the "tripped" position, reset as follows:</p> <ol style="list-style-type: none"> <li>(1) Push trip arm down.</li> <li>(2) Rotate latch up into position.</li> <li>(3) Raise trip arm until locking dog on trip arm engages the receptacle on the latch.</li> </ol> <p>d. Release center braked reel deployment tape stowed in nylon bag attached to lower left support arm by velcro tape.</p> <p>e. Stow braked reel deployment tape by draping it over a LM landing strut for convenient future access.</p> | <p>Prior to initiation of the subsequent procedures, crew should position TV camera to monitor all LRV deployment operations.</p> <p>To extent which lighting and landing angle permits inspect lower tube and bell crank assemblies, left side tube assembly, and upper tube and bell crank assemblies and verify there are no obstructions preventing the operation of these pin release mechanisms.</p> <p>Perform overall inspection of those portions of LRV and SSE which were previously obscured by the insulation blanket.</p> <p>Figure 2-1.</p> <p>Figure 2-2.</p> <p>Tape should be placed so that crewman is not required to move</p> |

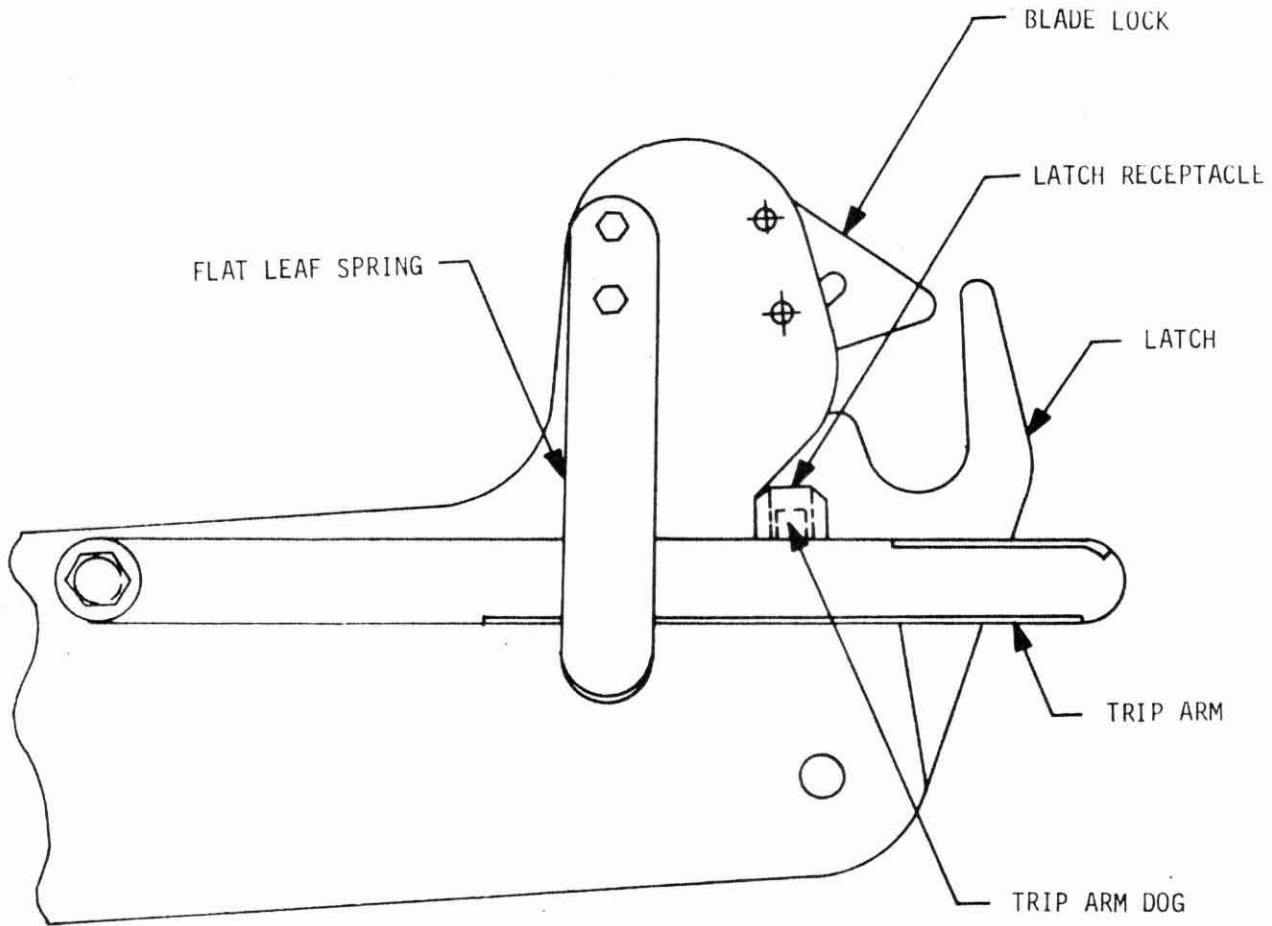

NOTE: LEFT SIDE SUPPORT  
ARM SHOWN. RIGHT  
SIDE SUPPORT ARM IS  
MIRROR IMAGE.

FIGURE 2-1 SUPPORT ARM LATCH MECHANISMS LATCHED CONFIGURATION

LS006-002-2H  
LUNAR ROVING VEHICLE  
OPERATIONS HANDBOOK

NOTE: DOUBLE BRAKED REEL  
DEPLOYMENT TAPE SIMILAR  
TO CENTER BRAKED REEL  
TAPE BUT STOWED ON  
RIGHT SIDE OF VEHICLE

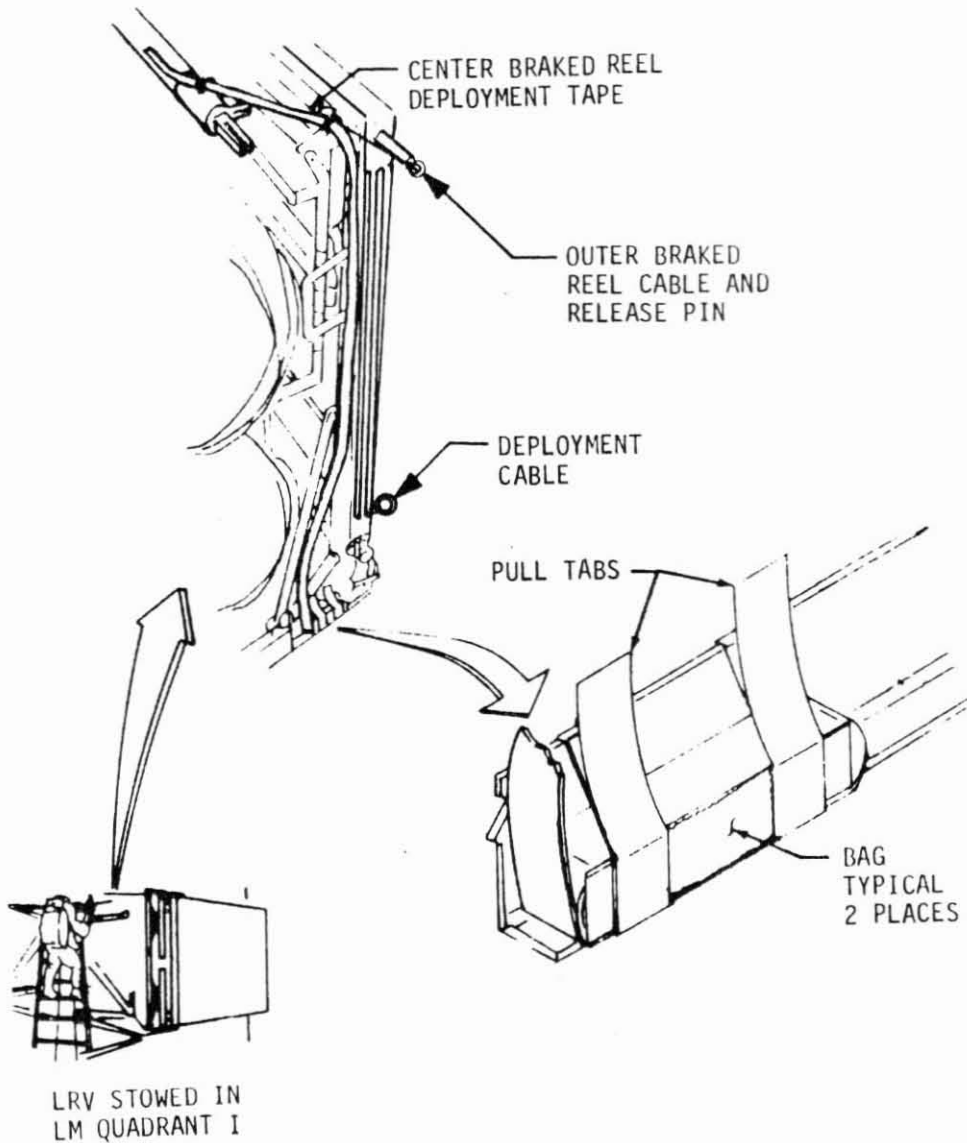

FIGURE 2-2 LRV DEPLOYMENT TAPES AND CABLES



Mission       J        
Basic Date 12/4/70  
Change Date 4/19/71  
Page 2-5

| STA/STEP | PROCEDURE   | REMARKS   |
|----------|---|---|
| 2.1      | (Continued)   | into limited space between LRV and LM landing leg.  |
|          | f. Release deployment cable from teflon clips on left side of LRV center chassis and deploy cable to maximum length and at 45° angle from Quad I toward descent ladder.   |   |
|          | g. Release double braked reel operating tape stowed in nylon bag attached to lower right support arm by velcro tape. Place tape in convenient location for future access.   |   |
|          | h. Ascend LM ladder.  |   |
|          | i. Inspect D-handle and bellcranks to verify there are no obstructions preventing operation.  | Figure 1-41.  |
|          | j. Inspect cable assembly connecting D-handle and bellcrank to ensure there is no fouling that would prevent operation.   |   |
|          | <div style="text-align: center; border: 2px dashed black; padding: 5px; width: fit-content; margin: 0 auto;"> <b>CAUTION</b> </div> <p>During and subsequent to deployment D-handle operation, both crewmen should remain out of the LRV deployment envelope.</p> | Figure 2-3.   |
|          | k. Pull LRV deployment D-handle. Verify LRV moves outward from LM about 4 degrees.  | Figure 2-4.   |
|          | NOTE: If push-off rod fails to rotate LRV about 4° outward from LM quadrant, deployment cable may be pulled to initiate LRV movement.   | First 5 to 6 inches of travel releases lower release pins, lower half of apex fittings may fall away immediately or during deployment rotation. The last segment of travel releases the upper pin. As the upper release pin is pulled, LRV rotates out of LM about 4 degrees. |

LS006-002-2H  
 LUNAR ROVING VEHICLE  
 OPERATIONS HANDBOOK

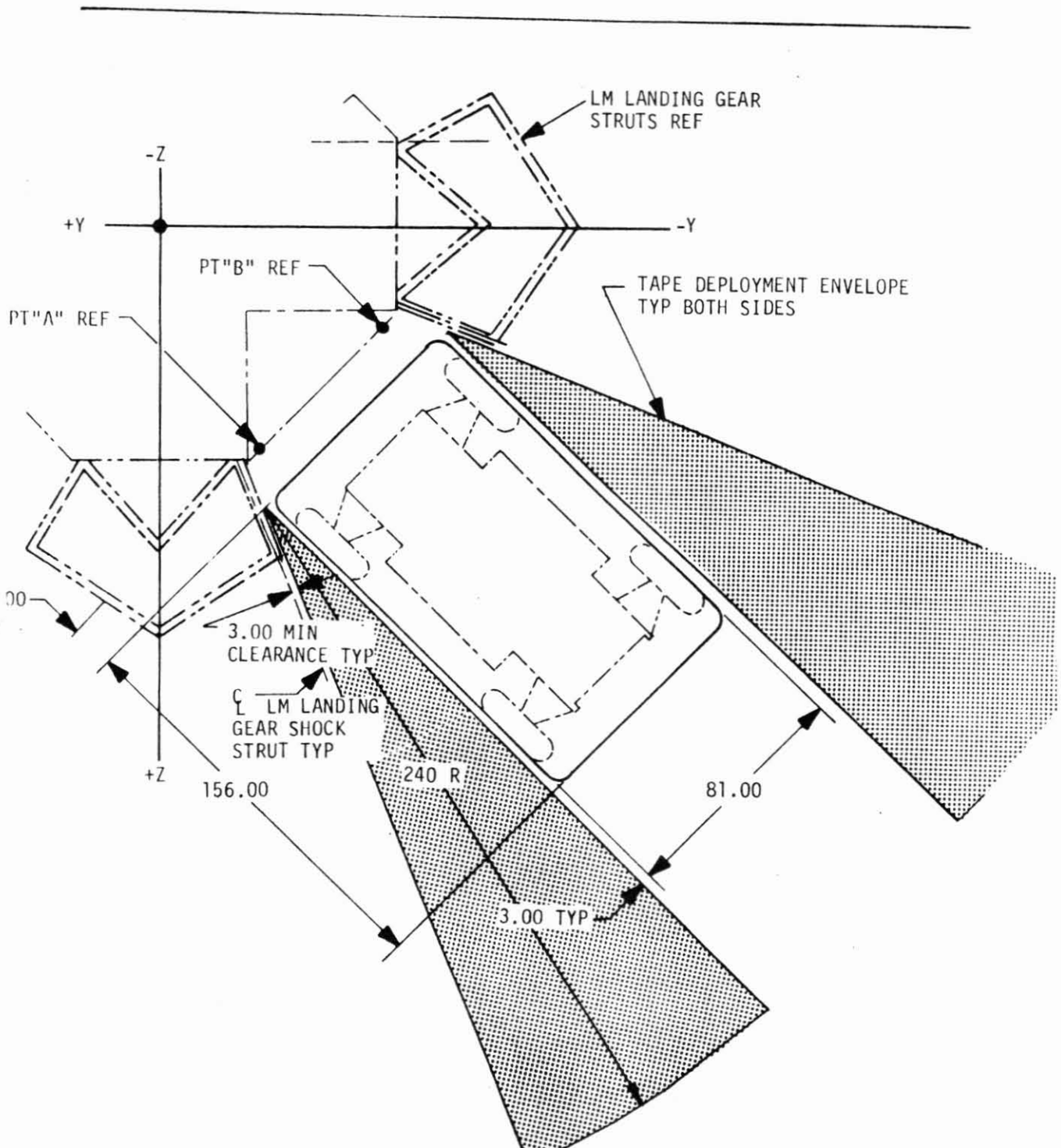

FIGURE 2-3 LRV DEPLOYMENT ENVELOPE AND ENVELOPE FOR DEPLOYMENT TAPE OPERATION

LS006-002-2H  
LUNAR ROVING VEHICLE  
OPERATIONS HANDBOOK

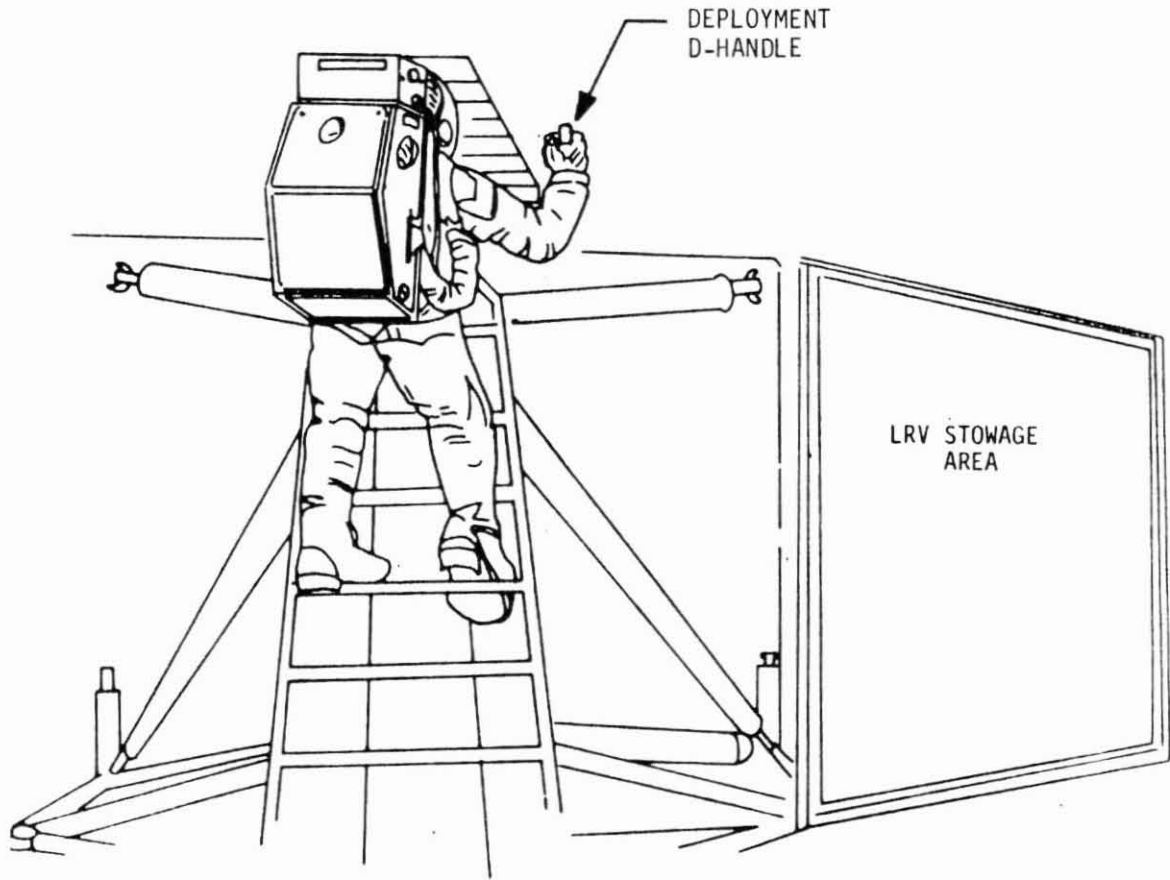
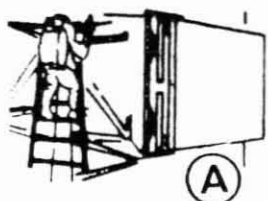

FIGURE 2-4 CREWMAN POSITIONED TO DEPLOY LRV

| STA/STEP | PROCEDURE  | REMARKS  |
|----------|--|--|
| 2.1      | <p>(Continued)</p> <p>l. Descend LM ladder. Grasp deployment cable and monitor deployment activity.</p> <p>m. Other crewman pulls double braked reel tape at right side of vehicle. Verify LRV rotates outward from LM (Figure 2-5, View B).</p> <p>NOTE: Crewman should remain within defined envelopes for deployment tape operation (Figure 2-3) to ensure that deployment tapes do not contact sensitive LM components.</p> <p>n. Continue to pull double braked reel tape (figure 2-5, View C). When vehicle rotates outboard to about 45 degrees, verify that:</p> <p>(1) Aft chassis unfolds and locks in position.<br/>           (2) Rear wheels unfold and tethered rear wheel struts fall free.<br/>           (3) Forward chassis is released from console post and returns to 35 degree position.</p> <p>NOTE: If either aft or forward chassis latch pins fail to pull automatically, deployment cable may be pulled to accomplish pin release.</p> <p>o. Continue to pull double braked reel tape (Figure 2-5, View D). Verify that:</p> <p>(1) Center/aft chassis rotates until rear wheels contact lunar surface.<br/>           (2) Rear wheels slide on surface permitting center/aft chassis to move away from LM.</p> | <p>Crewman operating deployment cable should keep slack out of double braked reel cables.</p> <p>For first 15 degrees of rotation LRV rotates on apex fittings, thereafter apex fittings lift off spools and rotation point shifts to walking hinge. Lower telescopic tubes ratchet engage at 35 degrees rotation.</p> <p>At about 45 degrees the 45° cable tightens, pulling the forward and aft chassis latch pins at the console post mount on the center chassis. The aft chassis and wheels fully deploy and the forward chassis returns to the 35° position.</p> <p>At about 73 degrees, the cam on forward sides of center chassis strikes latch lock arm, forces arm down out of retaining spring and unlocks latch.</p> |

LS006-002-2H  
LUNAR ROVING VEHICLE  
OPERATIONS HANDBOOK



- LRV STOWED IN QUADRANT
- ASTRONAUT REMOVES INSULATION BLANKET, OPERATING TAPES
- ASTRONAUT REMOTELY INITIATES AND EXECUTES DEPLOYMENT

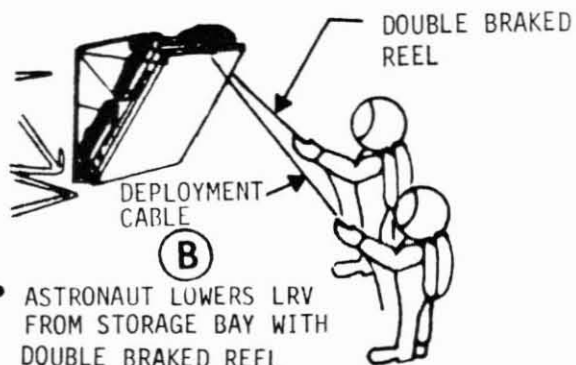

- ASTRONAUT LOWERS LRV FROM STORAGE BAY WITH DOUBLE BRAKED REEL

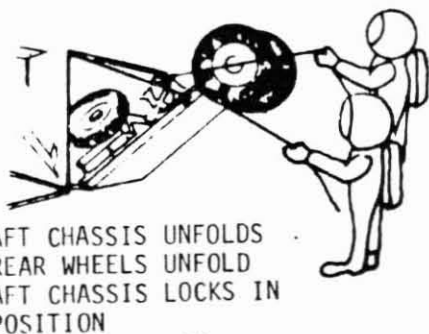

- AFT CHASSIS UNFOLDS
- REAR WHEELS UNFOLD
- AFT CHASSIS LOCKS IN POSITION

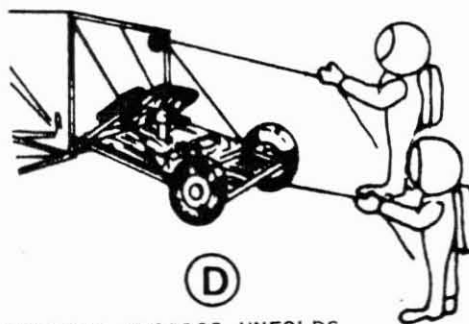

- FORWARD CHASSIS UNFOLDS
- FRONT WHEELS UNFOLD

CENTER BRAKED REEL

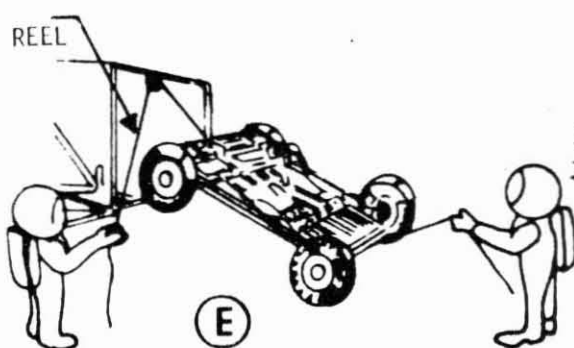

- FORWARD CHASSIS LOCKS IN POSITION. ASTRONAUT LOWERS LRV TO SURFACE WITH CENTER BRAKED REEL

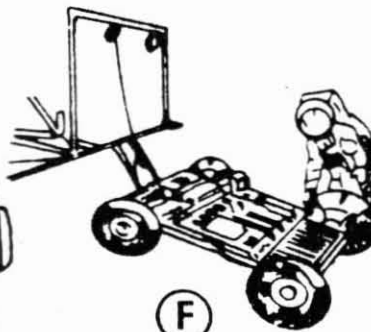

- ASTRONAUT DISCONNECTS SSE
- ASTRONAUT UNFOLDS SEATS, FOOTRESTS, (FINAL STOP)

FIGURE 2-5 LRV DEPLOYMENT SEQUENCE

Mission \_\_\_\_\_  
J \_\_\_\_\_  
Basic Date 12/4/70 \_\_\_\_\_  
Change Date 4/19/71 \_\_\_\_\_  
Page 2-10

| STA/STEP | PROCEDURE  | REMARKS  |
|----------|--|--|
| 2.1      | <p>(Continued)</p> <p>NOTE: If wheels fail to slide, deployment cable may be pulled to permit center/aft chassis to move away from LM.</p> <p>p. Continue to pull double braked reel tape (Figure 2-5, View D). Verify that:</p> <ul style="list-style-type: none"><li>(1) Forward chassis continues to unfold and locks in position.</li><li>(2) Forward wheels unfold.</li><li>(3) Outer braked reel cables are slack.</li><li>(4) 45° cable again becomes taut.</li></ul> <p>q. Release double braked reel tape and at chassis RR grasp outer braked reel cable in right hand and remove cable pin P8 (Figure 2-6) with left hand.</p> <p>r. Discard cable and pin outside work area.</p> <p>s. At chassis LR grasp outer braked reel cable in left hand and remove cable pin P1.</p> <p>t. Discard cable and pin outside work area.</p> <p>u. Pull center braked reel tape (Figure 2-5, View E). Verify that forward chassis lowers until all wheels contact lunar surface and support vehicle weight and 45° cable is slack.</p> <p>NOTE: If wheels fail to slide, deployment cable may be pulled to move LRV away from LM.</p> | <p>Forward wheel lock strut pins release and forward wheels deploy as the angle between the forward and center chassis approaches 170 degrees. (The 45 degree cable again becomes taut).</p> <p>At this time the forward and aft chassis sections are deployed and locked to the center chassis. All wheels are deployed. The forward chassis is held up by the telescopic tube assembly and the 45 degree cable.</p> <p>Figure 2-6.</p> <p>This tape was previously stowed over a LM landing strut for convenient access.</p> <p>Using deployment cable to pull the LRV, with parking brake</p> |

LS006-002-2H  
LUNAR ROVING VEHICLE  
OPERATIONS HANDBOOK

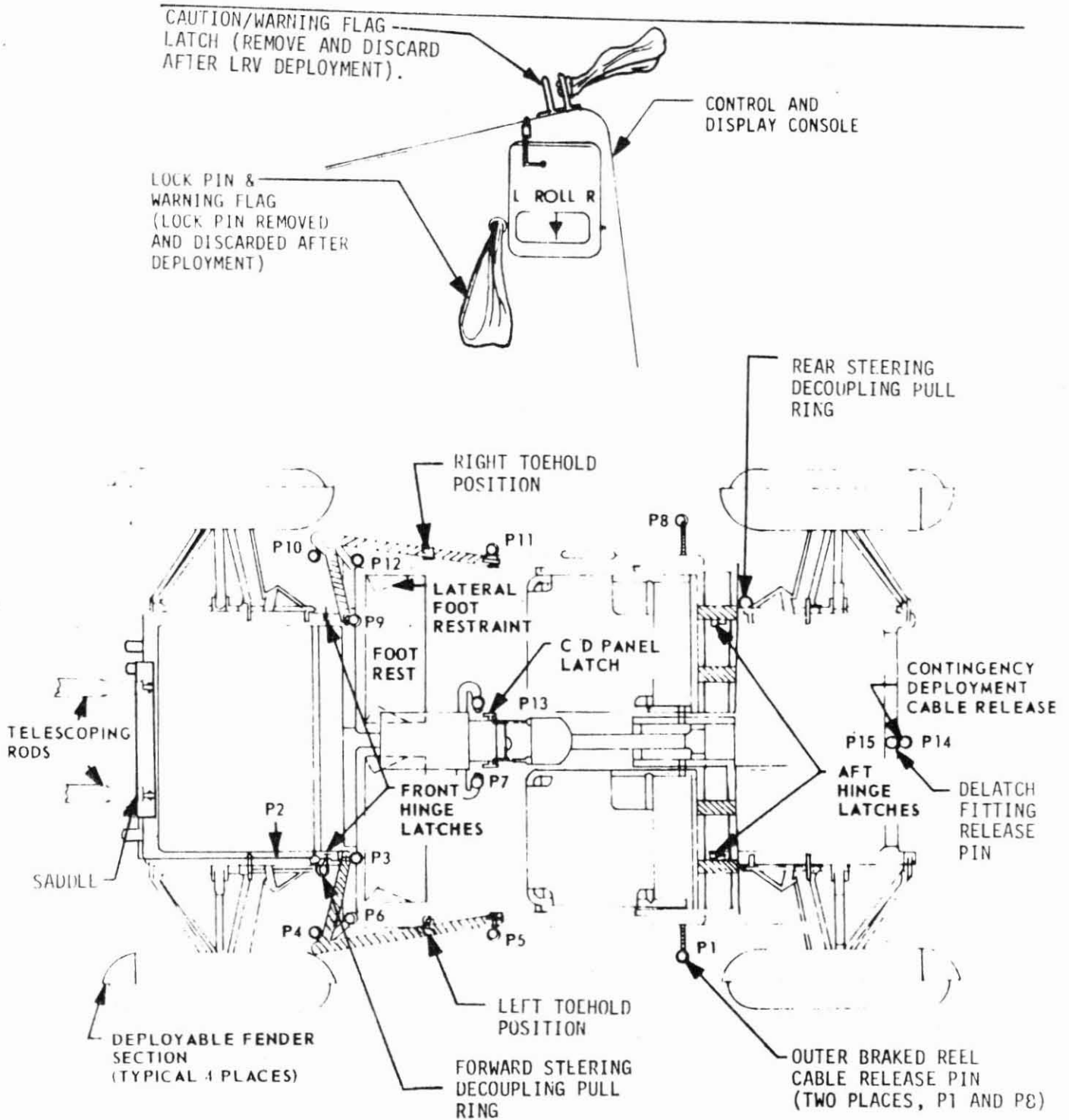

FIGURE 2-6 LRV DEPLOYMENT HARDWARE AND STEERING RING LOCATIONS (SHEET 1 OF 2)

LS006-002-2H  
LUNAR ROVING VEHICLE  
OPERATIONS HANDBOOK

NOTE: LEFT SIDE TRIPOD  
ASSEMBLY SHOWN. RIGHT  
SIDE PULL PIN NUMBERS  
SHOWN IN PARENTHESIS

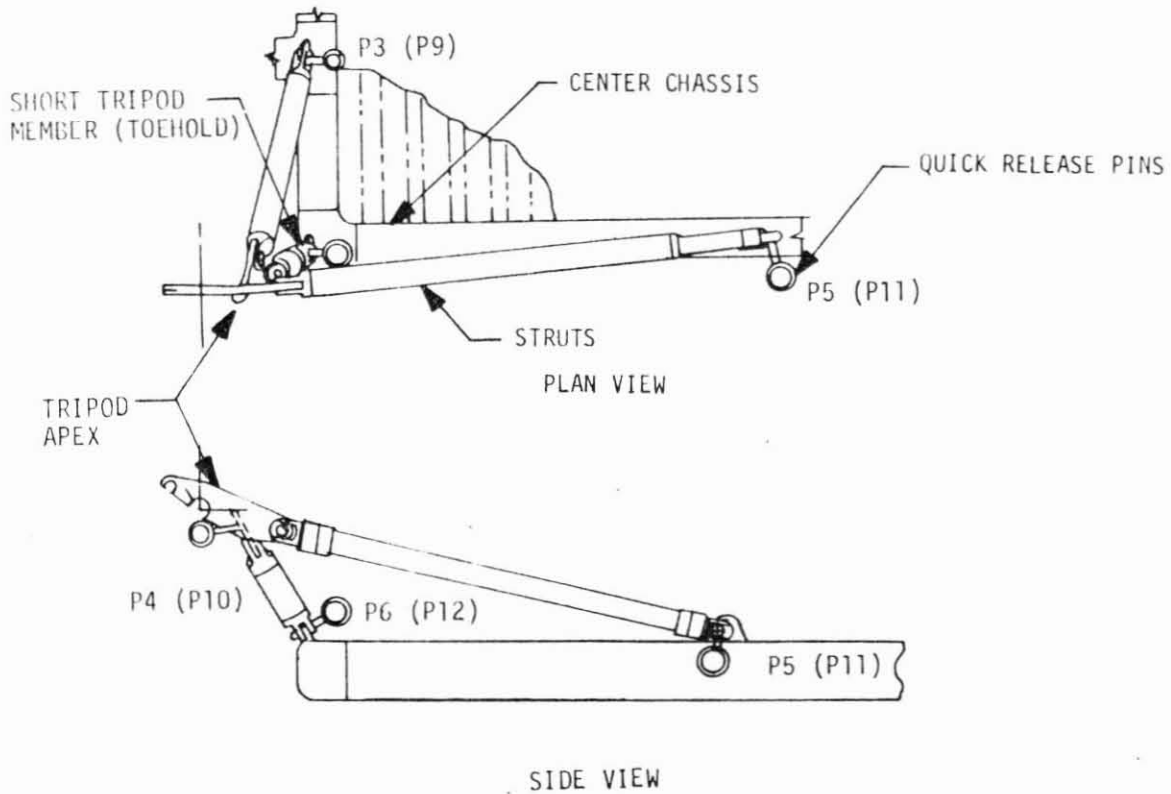

FIGURE 2-6 LRV DEPLOYMENT HARDWARE LOCATIONS (SHEET 2 OF 2)



Mission J  
 Basic Date 12/4/70  
 Change Date 4/19/71  
 Page 2-13

| STA/STEP | PROCEDURE  | REMARKS  |
|----------|--|--|
| 2.1      | <p>(Continued)</p> <p>v. Coil deployment cable and remove cable release pin P14 and chassis delatch fitting pin P15. Discard cable and deployment hardware outside of work area.</p> <p>w. Deploy RF fender extension.</p> <p>x. Verify both hinge pins flush at RF hinge.</p> <p>y. Remove pins P9 and P10 from right tripod and discard clear of deployment area.</p> <p>z. Grasp tripod apex with right hand and remove pin P11 with left hand.</p> <p>aa. Discard tripod main members and pin clear of deployment area.</p> <p>ab. Grasp remaining short tripod member in right hand, remove pin P12 with left hand, and discard pin clear of deployment area.</p> | <p>engaged and wheel struts tethered, should be kept to a minimum.</p> <p>Figure 2-6. When pin P14 is pulled, deployment cable and rear wheel tethers fall free of vehicle. When pin P15 is pulled, delatch fitting will either fall to surface or be retained in pinless fitting. If retained, pull fitting free at clevis and discard fitting.</p> <p>If hinge pin is not flush, tap pin with toehold subsequently removed in step ab. Verify pin is latched by pressing down on chassis.</p> <p>Figure 2-6.</p> |

L5006-002-2H  
 LUNAR ROVING VEHICLE  
 OPERATIONS HANDBOOK

Mission

J

Basic Date

12/4/70

Change Date

4/19/71

Page 2-14

| STAY/STEP | PROCEDURE  | REMARKS   |
|-----------|--|---|
| 2.1       | (Continued)  |   |
| ac.       | Remove short tripod member and insert tripod member in right toehold position or stow in underseat stowage bag.        | If short tripod member is installed in toehold position, end with hook should be outboard with hook pointing forward. This is also used as wheel decoupling tool. |
| ad.       | Pull right footrest lift tabs.   | Figure 2-7. Tabs pull free of footrests but remain attached to the floor panel.   |
| ae.       | Rotate footrest upward and forward and lock into position.   |   |
| af.       | Release velcro tiedown strap (if necessary), pull out right C/D console "T" handle P13 with left hand and turn 90° CW. | Figure 2-8.   |
| ag.       | Release right seat belt from stowage position and stow in temporary location.  | Figure 2-9.   |
| ah.       | Rotate right seat to stable overcenter position.   |   |
| ai.       | Rotate legs to full upright position.  |   |
| aj.       | Attach forward seat legs velcro strap to outboard handhold.  |   |
| ak.       | Verify underseat stowage bag erects.   |   |
| al.       | Pull seat pan frame forward to engage front legs.  |   |
| am.       | Verify all seat latches latched.   |   |
| an.       | Verify both hinge pins flush at RR hinge.  | If hinge pin is not flush, tap pin with toehold. Verify pin is latched by pressing down on chassis.   |

LS006-002-2H  
 LUNAR ROVING VEHICLE  
 OPERATIONS HANDBOOK

LS006-002-2H  
LUNAR ROVING VEHICLE  
OPERATIONS HANDBOOK

---

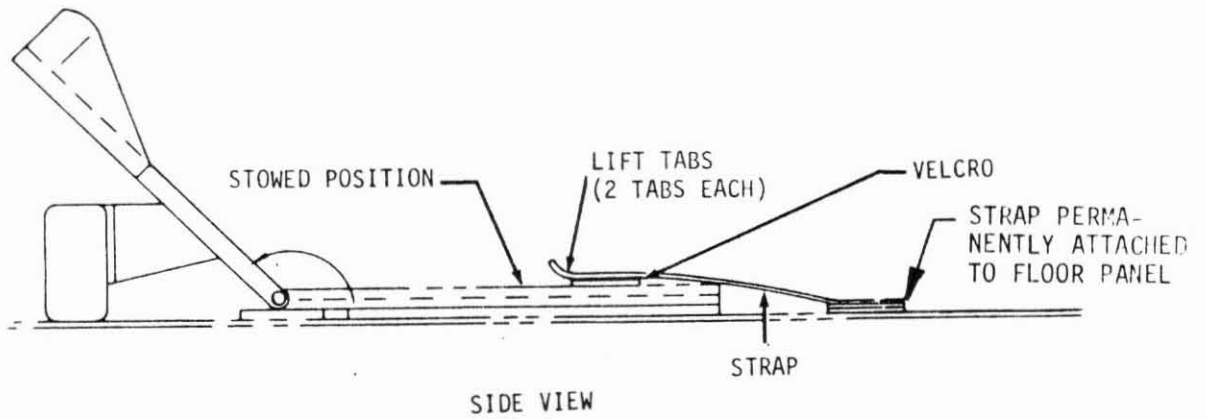
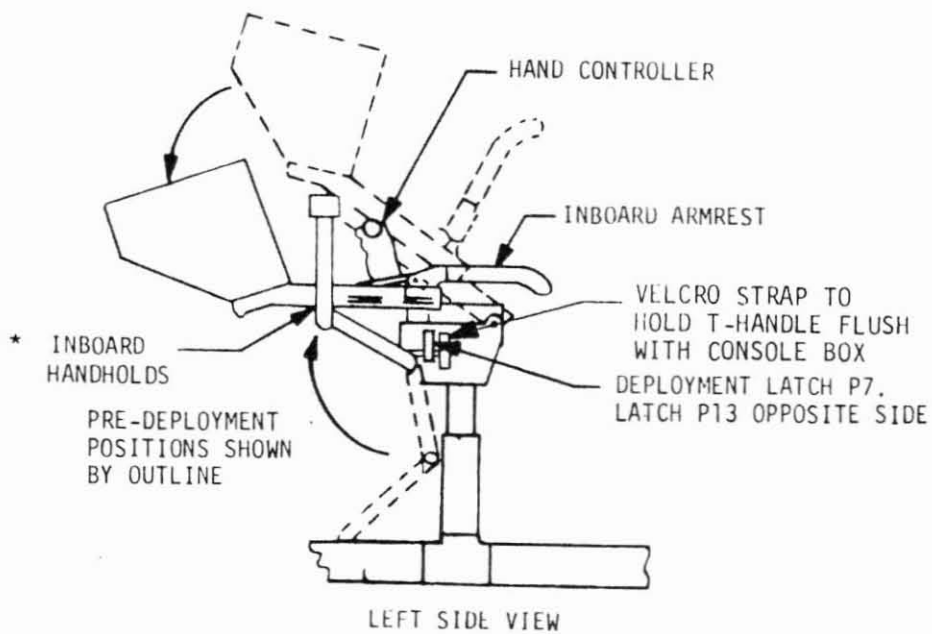

FIGURE 2-7 FOOT REST DEPLOYMENT

LS006-002-2H  
LUNAR ROVING VEHICLE  
OPERATIONS HANDBOOK



\* IG TRAINER INBOARD HANDHOLD CANNOT BE FOLDED DOWN TO SIMULATE PRE-DEPLOYMENT POSITION DUE TO CABLE RUNS FROM CONSOLE.

FIGURE 2-8 CONTROL AND DISPLAY CONSOLE DEPLOYMENT

LS006-002-2H  
LUNAR ROVING VEHICLE  
OPERATIONS HANDBOOK

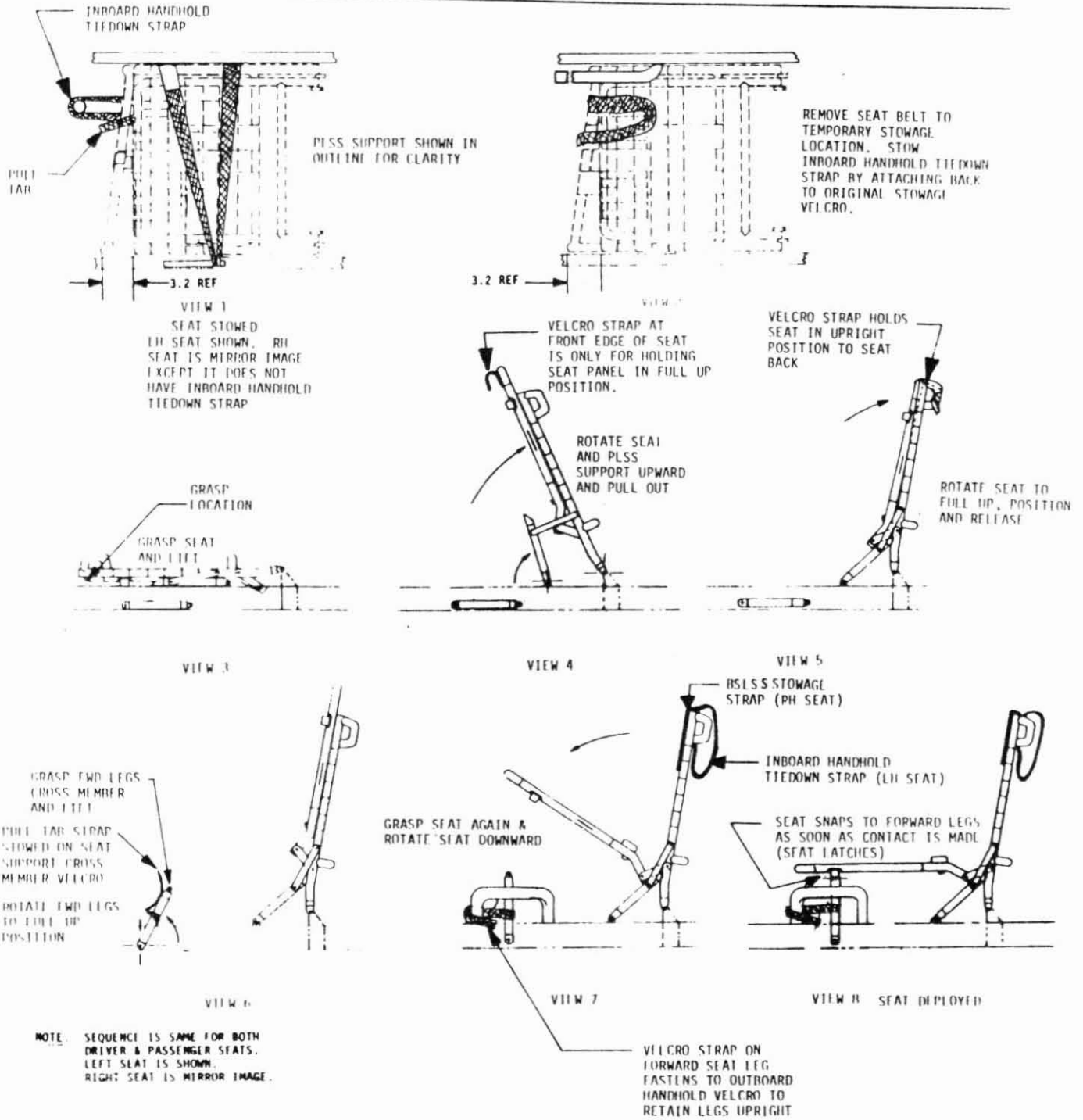

FIGURE 2-9 SEAT AND PLSS SUPPORT DEPLOYMENT SEQUENCE

Mission 3 Basic Date 12/4/70 Change Date 4/19/71 Page 2-18

| STA/STEP | PROCEDURE   | REMARKS   |
|----------|---|---|
| 2.1      | (Continued)   | on chassis.   |
| ad.      | Visually verify the rear steering decoupling pull ring seal has not been broken.      | Figure 2-6. If pull ring tie-down seal is broken and subsequent steering check using hand controller indicates steering is engaged, disregard broken seal. If hand controller check indicates steering is not engaged, recouple steering. |
| ac.      | Deploy RR fender extension.   |   |
| ad.      | Deploy LR fender extension.   |   |
| ar.      | Verify both hinge pins flush at LR hinge.   | If hinge pin is not flush, tap pin with tcehold. Verify pin is latched by pressing down on chassis.   |
| as.      | Release inboard handhold velcro tiedown strap.  | Figure 2-9, View 1.   |
| at.      | Release seat belt from seat stowage position and place in temporary storage position. | Figure 2-9, View 2.   |
| au.      | Rotate seat to stable overcenter position.  |   |
| av.      | Rotate legs to full upright position.   |   |
| aw.      | Attach forward seat legs velcro strap to outboard handhold.                           |   |
| ax.      | Verify underseat stowage bag erects.  |   |
| ay.      | Pull seat pan frame forward to engage front legs.                                     |   |

| MISSION  | J  | Basic Date | 12/4/70 | Change Date | 4/19/71 | Page | 2-19   |
|----------|--|------------|---------|-------------|---------|------|--|
| STA/STEP | PROCEDURE  |            |         |             |         |      | REMARKS  |
| 2.1      | (Continued)  |            |         |             |         |      |  |
| az.      | Verify all seat latches latched.   |            |         |             |         |      |  |
| ba.      | Stow inboard handhold tiedown strap by making loop behind seat and attaching end of strap to velcro patch on top of seat back.                       |            |         |             |         |      |  |
| bb.      | Fold inboard armrest down.   |            |         |             |         |      | To prevent interference with hand controller armrest must be folded down to extent possible at this point. |
| bc.      | Support console with left hand, with right hand release velcro tiedown strap (if required), pull out left C/D console "T" handle P7 and turn 90° CW. |            |         |             |         |      |  |
| bd.      | With right hand rotate inboard handhold to locked position while rotating console downward with left hand.   |            |         |             |         |      |  |
| be.      | Rotate "T" handle P7 90° CW with right hand, fold "T" handle flush with console box and secure in position with velcro strap.                        |            |         |             |         |      | "T" handle should "snap-in", lock and fold down flush with console box.                                    |
| bf.      | Remove attitude indicator lock pin and discard.  |            |         |             |         |      | Figure 2-6.  |
| bg.      | Remove C&W flag lock pin and discard.  |            |         |             |         |      |  |
| bh.      | Pull pins P3 and P4 and discard clear of work area.  |            |         |             |         |      |  |
| bi.      | Grasp tripod apex with left hand and pull pin P5.  |            |         |             |         |      |  |
| bj.      | Discard pins and apex members clear of work area.  |            |         |             |         |      |  |
| bk.      | Grasp short tripod member in left hand and pull pin P6 with right hand, and discard pin clear of deployment area.                                    |            |         |             |         |      |  |

Mission

1

Basic Date

12/4/70

Change Date

4/19/71

Page 2-20

| STA/STEP | PROCEDURE  | REMARKS  |
|----------|--|--|
| b1.      | Remove short tripod member and use hooked end to pull cable P2.                              | Figure 2-6. Tool hook interfaces with cable area color coded gold. Deflection of cable releases telescoping rods saddle and forward wheel strut tethers.                               |
| bm.      | Visually verify that telescoping rods saddle falls away from LRV.                            |  |
| bn.      | Either insert short tripod member in left toehold position or stow in underseat stowage bag. | Figure 2-6. If short tripod member is installed in toehold position, end with hook should be outboard with hook pointing forward. This is also used as wheel decoupling tool.          |
| bo.      | Pull left footrest lift tabs.  | Tabs pull free of footrests, but remain attached to floor panel.   |
| bq.      | Rotate footrest upward and forward and lock into position.                                   |  |
| br.      | Verify both hinge pins flush at LF hinge.  |  |
| bs.      | Deploy LF fender extension.  |  |
| bt.      | Verify battery no. 1 and SPU dust covers closed and secured to velcro patch.                 |  |
| bu.      | Verify the forward steering decoupling pull ring seal has not been broken.                   | Figure 2-6. If seal is broken and subsequent steering check using hand controller indicates steering is engaged, disregard broken seal. If hand controller check indicates steering is |

LS006-007-2H  
LUNAR ROVING VEHICLE  
OPERATIONS HANDBOOK



Mission

J

Basic Date

12/4/70

Change Date

4/19/71

Page 2-21

| STA/STEP | PROCEDURE   | REMARKS   |
|----------|---|---|
| 2.1      | (Continued)<br><br>bv. Move to right side of vehicle and verify battery no. 2 dust cover closed and secured to velcro patch.<br><br>bw. At right side of LRV rotate right "T" handle P13 90° CW, fold "T" handle flush with console box and secure in position with velcro strap. | not engaged, center wheels in neutral steer, verify forward steering lock and continue mission using rear steering only.<br><br>"T" handle should snap-in, lock and fold down flush with the console box. |

LS006-002-2H  
LUNAR ROVING VEHICLE  
OPERATIONS HANDBOOK

| STA/STEP | PROCEDURE  | REMARKS  |
|----------|--|--|
| 2.2      | <p>LRV POST DEPLOYMENT CHECKOUT AND DRIVE TO MESA</p> <p>a. Verify hand controller in parking brake and neutral throttle position and reverse inhibit switch is on (pushed down).</p> <p>b. Verify switches and circuit breakers in pre-launch positions as follows:</p> <p>NAV POWER Circuit Breaker - Open<br/>           GYRO TORQUING Switch - OFF<br/>           System RESET Switch - OFF<br/>           AUX Circuit Breaker - Open<br/>           BUS A, B, C, D, Circuit Breakers - Open<br/>           + 15 DC PRIM and SEC Circuit Breakers - Open<br/>           + 15 DC Switch - OFF<br/>           MOTOR TEMP Switch - FORWARD<br/>           BATTERY Switch - AMPS<br/>           PWM SELECT Switch - BOTH<br/>           STEERING FORWARD and REAR Circuit Breakers - Open<br/>           STEERING FORWARD and REAR Switches - OFF<br/>           DRIVE POWER LF, RF, LR, RR Circuit Breakers - Open<br/>           DRIVE POWER LF, RF, LR, RR Switches - OFF<br/>           DRIVE ENABLE LF, RF, LR, RR Switches - OFF</p> <p>c. Manually move the LRV away from the LM. (See remarks for LRV configuration for this operation).</p> | <p>Crewman stands along side the vehicle.</p> <p>Figure 2-11. Crewman stands along side vehicle.</p> <p>Crew may manually move LRV away from LM prior to powerup; the hand controller should be placed in neutral throttle position and parking brake released. With a crewman standing on either side of vehicle outboard handholds may be used to lift, move, and tow LRV to any desired location.</p> |

Mission \_\_\_\_\_

Basic Date \_\_\_\_\_

12/4/70

Change Date \_\_\_\_\_

4/19/71

Page 2-22

Mission     J     Basic Date 12/4/70 Change Date 4/19/71 Page 2-23

| STA/STEP | PROCEDURE   | REMARKS   |
|----------|---|---|
| 2.2      | <p>(Continued)</p> <p>d. Set parking brake.</p> <p>e. Ingress left seat, fasten seat belt and initiate subsequent power up steps.</p> <p>f. BUS A, BUS B, BUS C, BUS D Circuit Breakers - Close.</p> <p>g. BATTERY Switch - VOLTS x 1/2.</p> <p>h. Report BAT 1 and BAT 2 VOLTS indications.</p> <p>i. BATTERY Switch - AMPS.</p> <p>j. Report BAT 1 and BAT 2 temp (°F) indications.</p> <p>k. Report BAT 1 and BAT 2 AMP-HR indications.</p> <p>l. Report BAT 1 and BAT 2 AMPS indications.</p> <p>m. <u>±</u> 15 VDC PRIM and SEC Circuit Breakers - Close.</p> <p>n. STEERING FORWARD AND REAR Circuit Breakers - Close.</p> <p>o. DRIVE POWER LF, RF, LR, RR Circuit Breakers - Close.</p> | <p>Lunar weight of LRV at this point would be approximately 85 lbs. Hand controller is placed in neutral throttle position and brake disengaged to permit wheels to roll.</p> <p>Crewman stands along side vehicle, and should exercise care not to move vehicle while setting brake.</p> <p>Figure 2-1C.</p> |

LS006-002-2H  
LUNAR ROVING VEHICLE  
OPERATIONS HANDBOOK

LS006-002-2H  
LUNAR ROVING VEHICLE  
OPERATIONS HANDBOOK

SEAT BELT PLACED ON INBOARD  
HANDHOLD FOR STORAGE PRIOR TO  
VEHICLE EGRESS

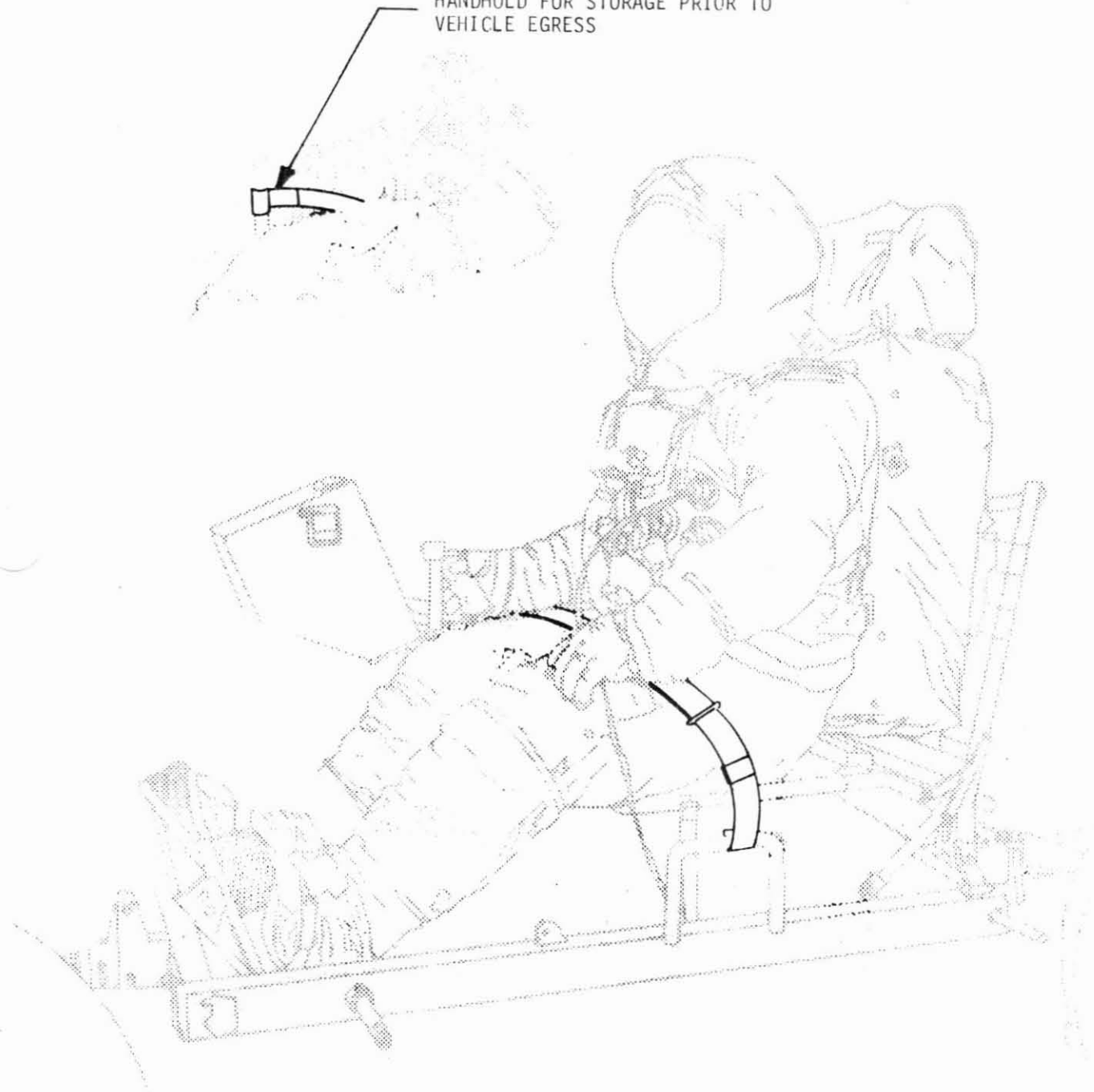

FIGURE 2-10 CREW POSITION

LS006-002-2H  
 LUNAR ROVING VEHICLE  
 OPERATIONS HANDBOOK

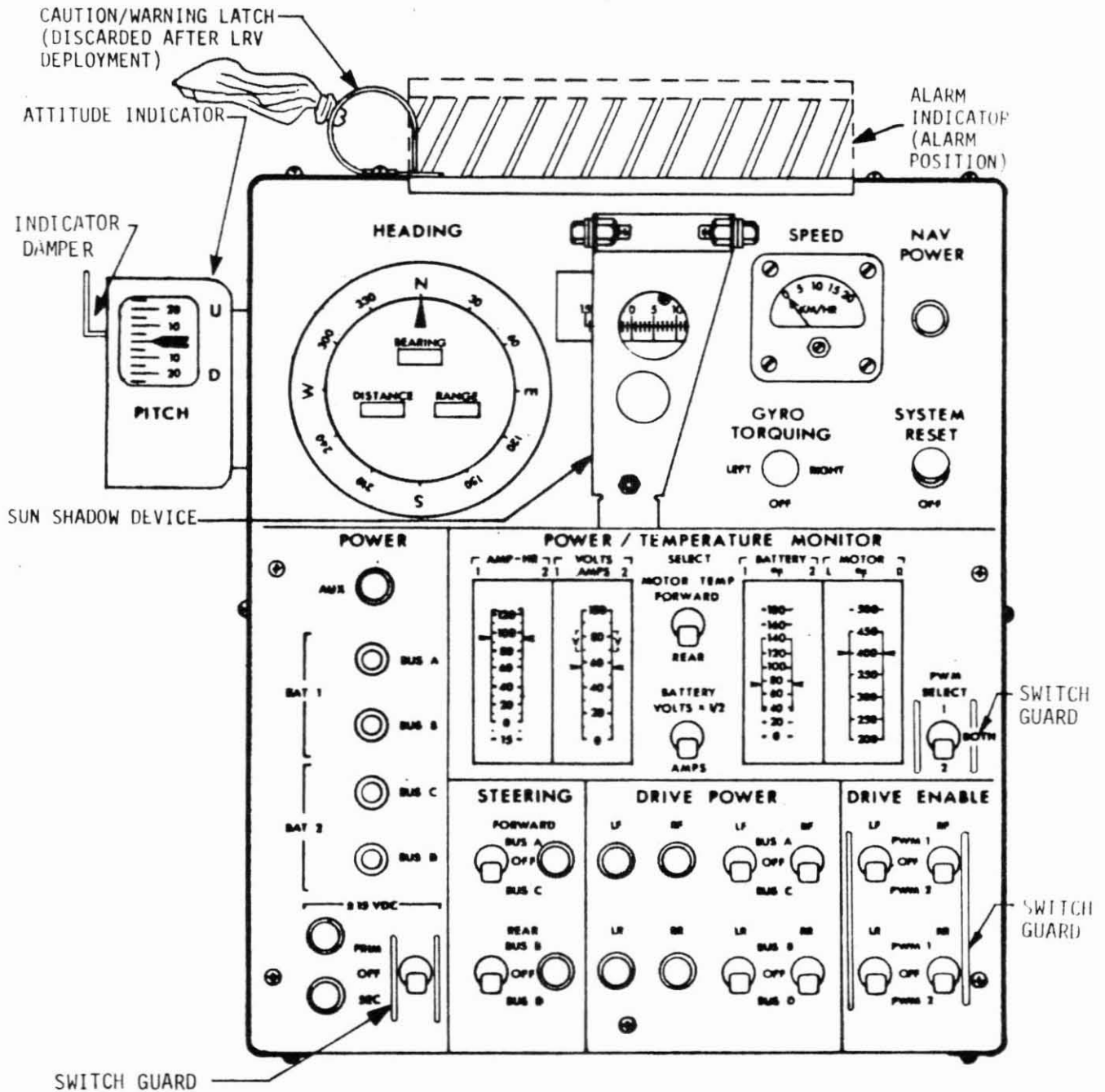

FIGURE 2-11 CONTROL AND DISPLAY CONSOLE



Mission

J

Basic Date

12/4/70

Change Date

4/19/71

Page 2-27

| STA/STEP | PROCEDURE   | REMARKS  |
|----------|---|--|
| 2.2      | <p>(Continued)</p> <p>x. DRIVE POWER RR Switch - BUS B.</p> <p>y. Release parking brake.</p> <p>z. Hand Controller reverse inhibit switch - UP position.</p> <p>NOTE: The LRV driver may now back away from LM. LRV driver should request other crewman to direct and monitor any backing operations from an off-vehicle position.</p> <p>aa. Stop LRV and set parking brake. Reset reverse inhibit switch (push switch down).</p> <p>ab. Release parking brake and drive to MESA area for equipment loading.</p> <p>ac. Stop LRV and set hand controller in parking brake position; Neutral throttle.</p> <p>ad. Perform LRV partial power down as follows:</p> <p>DRIVE POWER Switches (4) - OFF.<br/>           STEERING Switches (2) - OFF.<br/>           + 15 VDC Switch - OFF.</p> | <p>To the extent possible driver should verify steering, speed control and braking during this brief drive. The off-vehicle crewman should verify all four wheels rotating (not sliding).</p> <p>Parking brake should always be set prior to vehicle egress by either crewman.</p> <p>Turning off drive power, steering, and + 15 VDC switches ensures that a failure in the DCE will not apply power to any vehicle motor thereby precluding any unnecessary power drain.</p> |

LS006-002-2H  
 LUNAR ROVING VEHICLE  
 OPERATIONS HANDBOOK

Mission J Basic Date 12/4/70 Change Date 4/19/71 Page 2-28

| STA/STEP | PROCEDURE   | REMARKS |
|----------|---|---------|
| 2.2      | <p data-bbox="437 229 588 256">(Continued)</p> <p data-bbox="319 347 1193 491">NOTE: The above step 2.2.ad assumes that payload loading and first LRV traverse will follow in order. Should crew rest period be scheduled subsequent to step 2.2.ae and prior to first LRV sortie, then Bus A, B, C, and D circuit breakers should be opened.</p> <p data-bbox="267 523 996 550">ae. Release and stow seat belt and egress vehicle.</p> |         |

LS006-002-2H  
LUNAR ROVING VEHICLE  
OPERATIONS HANDBOOK



Mission     J     Basic Date 12/4/70 Change Date 4/19/71 Page 2-29

| STA/STEP | PROCEDURE   | REMARKS   |
|----------|---|---|
| 2.3      | PAYLOAD LOADING   |   |
| 2.3.1    | LCRU Installation   |   |
|          | a. Place LCRU support post locks in the up position.  | Figure 2-12. LRV arrives on lunar surface with LCRU support posts installed in LRV support tubes on forward chassis and with LRV/LCRU power cable connected to LRV auxiliary connector. |
|          | b. Disconnect GCTA connector from LRV dummy connectors.   | Figure 2-12.  |
|          | NOTES   |   |
|          | 1. Do not disconnect LCRU power cable from LRV auxiliary connector. Dust contamination could occur if this connector is disconnected. |   |
|          | 2. Do not allow GCTA connector of cable to fall to lunar surface.   |   |
|          | 3. Do not place payload on battery cover.   |   |
|          | c. Remove dummy connector from LRV GCTA receptacle and discard.   |   |
|          | d. Remove LCRU from its LM stowage position and place onto LRV forward chassis LCRU support posts.                                    | Figure 2-13.  |
|          | e. When LCRU is bottomed against support posts, position support post locks in horizontal position to secure LCRU.                    |   |
|          | f. Verify LRV AUX power circuit breaker - Open.   |   |

LS006-002-2H  
 LUNAR ROVING VEHICLE  
 OPERATIONS HANDBOOK

LS006-002-2H  
LUNAR ROVING VEHICLE  
OPERATIONS HANDBOOK

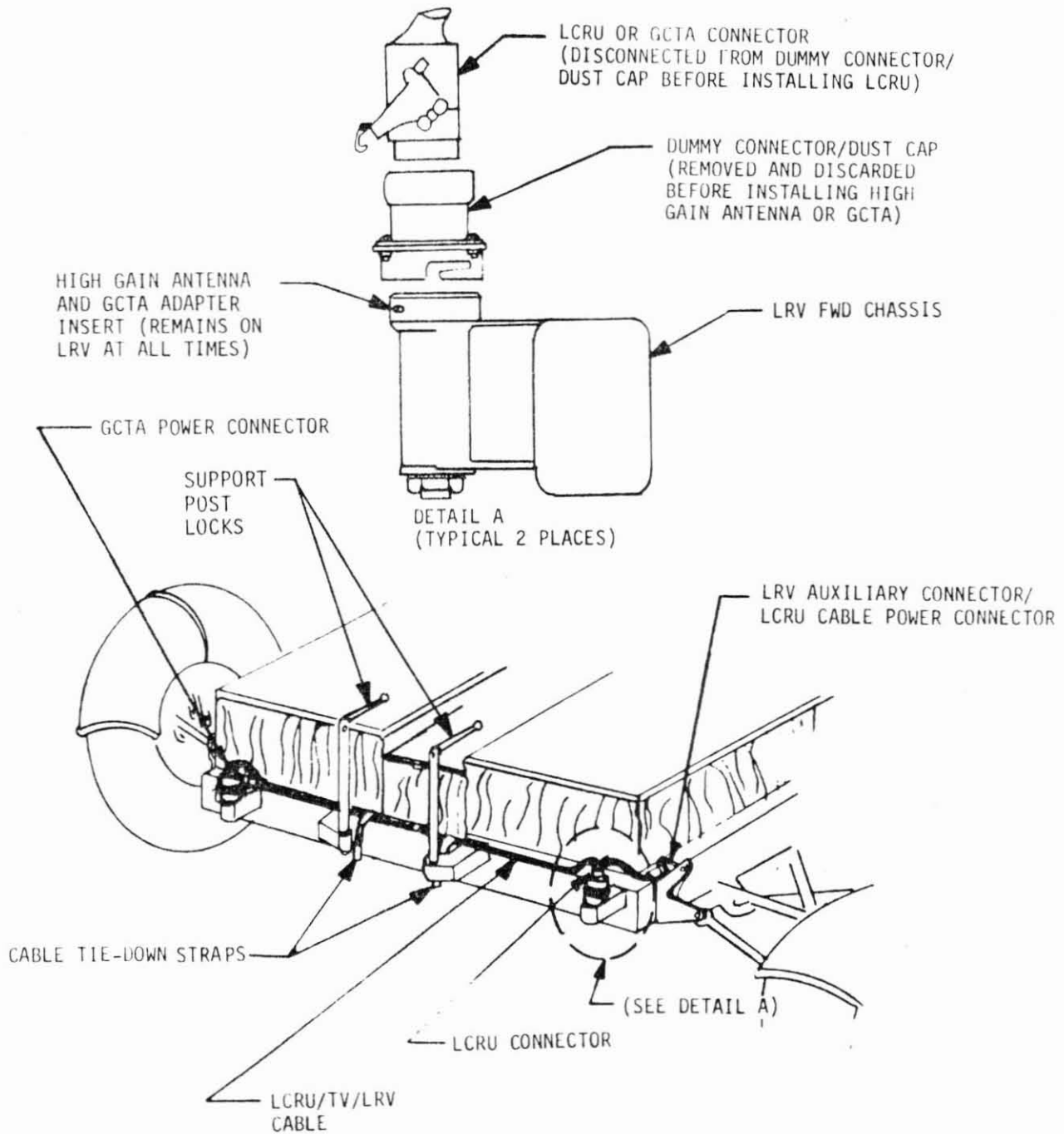

FIGURE 2-12 LCRU/TV/LRV CABLE STOWAGE

1175603

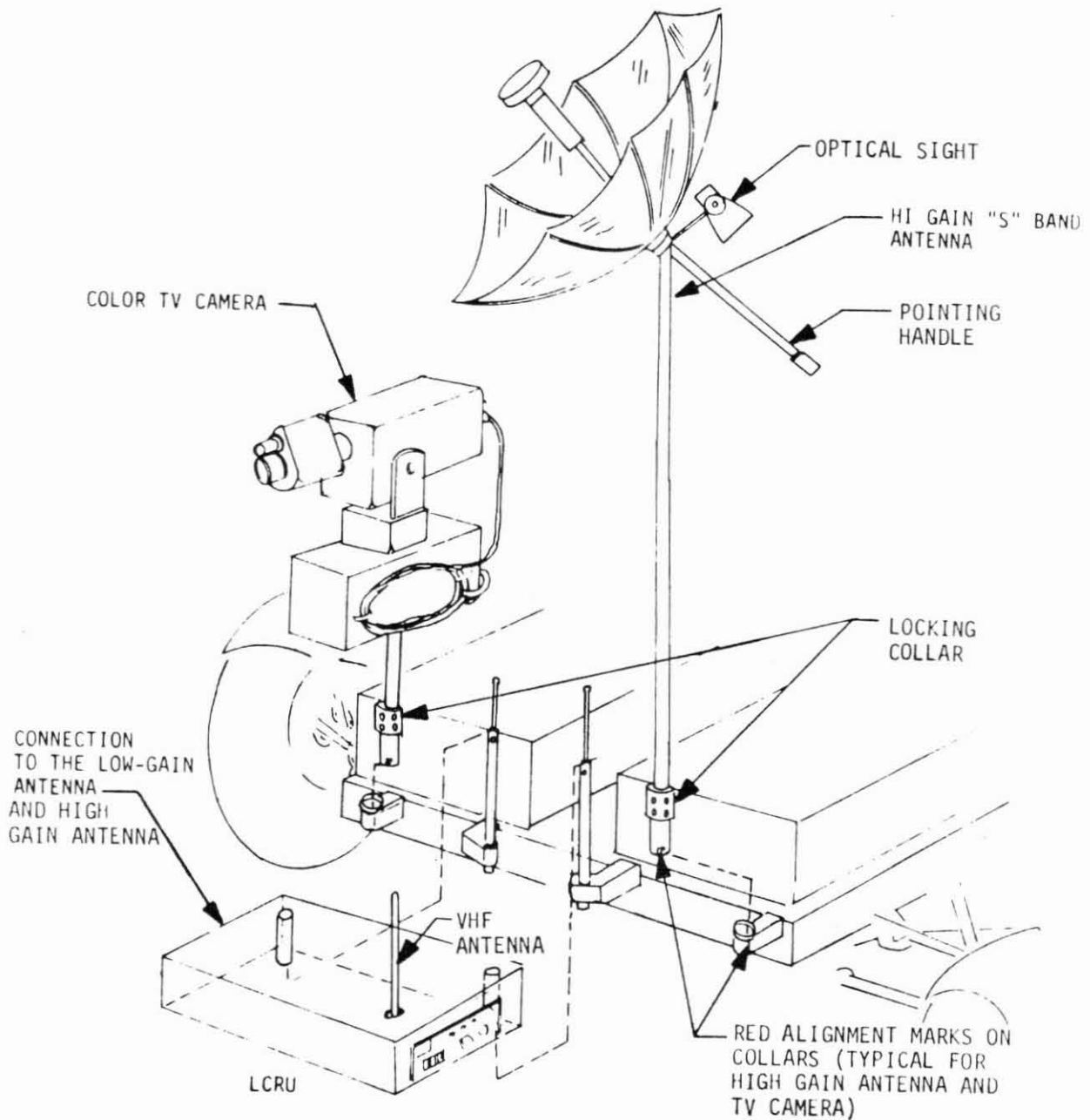

FIGURE 2-13 LCRU, HIGH GAIN ANTENNA, TV CAMERA INSTALLATION

Mission            J            Basic Date 12/4/70 Change Date 4/19/71 Page 2-32

| STA/STEP | PROCEDURE   | REMARKS  |
|----------|---|--|
| 2.3 .1   | <p>(Continued)</p> <p>g. Disconnect LCRU power connector from LRV dummy connector and connect to LCRU.</p> <p>h. Cover connector with thermal boot.</p> <p>i. Remove dummy connector from LRV HGA receptacle and discard.</p> |  |
| 2.3.2    | GCTA Installation   | Figure 2-13.   |
| a.       | At MESA, pull GCTA control unit pip pin release cable.  |  |
|          | <p style="text-align: center;"><b>CAUTION</b></p> <p>Do not strike GCTA control unit mirror surfaces on MESA.</p>   |  |
| b.       | Remove GCTA control unit and support staff from MESA.   |  |
| c.       | Unfold GCTA support staff. Verify staff locked.   |  |
|          | <p style="text-align: center;"><b>CAUTION</b></p> <p>If GCTA staff is not properly locked, it could fall on LCRU and cause severe LCRU radiator damage.</p>   |  |
| d.       | With connector receptacles inboard, insert GCTA staff into mounting receptacle on right front corner of LRV.  |  |
| e.       | Rotate staff to assure engagement of staff anti-rotational pins.  |  |
| f.       | GCTA staff bayonet collar - Lock (CW).  | Alignment marks are provided on GCTA staff locking collar. |

LS00:-002-2H  
LUNAR ROVING VEHICLE  
OPERATIONS HANDBOOK

Mission 3  
 Basic Date 12/4/70  
 Change Date 4/19/71  
 Page 2-33

| STA/STEP | PROCEDURE   | REMARKS      |
|----------|---|--------------|
| 2.3.2    | (Continued)   |              |
| g.       | Connect GCTA connector of LRV/LCRU cable to GCTA control unit.  |              |
| h.       | On TV camera, LM PWR Switch - OFF.  |              |
| i.       | Disconnect LM/TV cable from TV camera and rest connector on tripod handle.  |              |
| j.       | Remove TV camera from LM tripod and install on GCTA azimuth/elevation unit.   |              |
| k.       | Connect GCTA control unit connector to TV camera.   |              |
| 2.3.3    | 16 mm Data Acquisition Camera Installation  | Figure 2-14. |
| a.       | Remove camera and staff from LM.  |              |
| b.       | Assemble camera and staff into single unit.   |              |
| c.       | Insert staff into receptacle on LRV right inboard handhold.   |              |
| d.       | Verify staff locked in place by pulling up on the camera without depressing the push button on end of handhold. Camera staff should not move vertically.  |              |
| 2.3.4    | Low Gain Antenna Installation   | Figure 2-14. |
| a.       | Remove low gain antenna from LM stowage location.   |              |
| b.       | Insert low gain antenna staff on LRV left inboard handhold.   |              |
| c.       | Verify staff locked in vertically by pulling up on staff without depressing button on end of handhold. Low gain antenna staff should not move vertically. |              |

LS006-002-21  
 LUNAR ROVING VEHICLE  
 OPERATIONS HANDBOOK

LS006-002-2H  
LUNAR ROVING VEHICLE  
OPERATIONS HANDBOOK

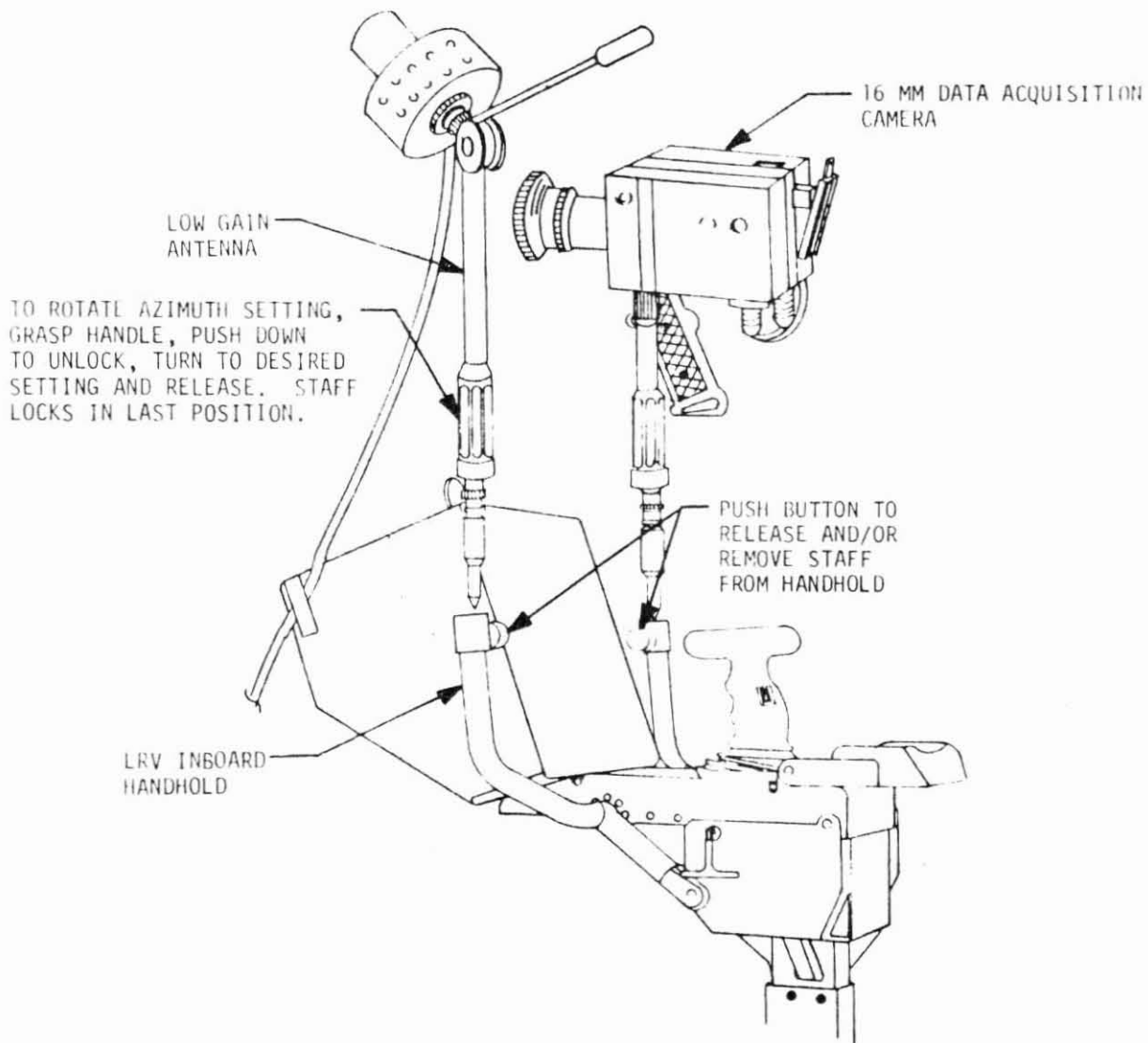

FIGURE 2-14 16 MM DAC AND LOW GAIN ANTENNA INSTALLATION

Mission J  
 Basic Date 12/4/70  
 Change Date 4/19/71  
 Page 2-35

| STA/STEP | PROCEDURE   | REMARKS   |
|----------|---|---|
| 2.3.4    | (Continued)   |   |
|          | d. Route low gain antenna cable to LCRU and secure to LRV with strap on console and clips on forward chassis. | Figure 2-15.  |
|          | e. Connect low gain antenna cable to LCRU.  |   |
| 2.3.5    | High Gain Antenna Installation.   | Figure 2-13.  |
|          | a. Remove high gain antenna from LM stowage position.   |   |
|          | b. Insert high gain antenna staff into the mounting receptacle on the left front corner of the LRV and lock.  | Alignment marks are provided on HGA staff locking collar. |
|          | c. Unfold and lock HGA staff.   |   |
|          | d. Remove and discard optical sight retaining clamp.  |   |
|          | e. Open and lock HGA dish.  |   |
|          | f. Connect HGA cable to the LCRU.   |   |
|          | g. Activate LCRU/GCTA and perform communication checks as required.   |   |
|          | h. Deactivate LCRU/GCTA until needed.   |   |
| 2.3.6    | Aft Payload Pallet Installation   |   |
|          | a. Release the pallet support post tiedown on LRV aft chassis.  | Figure 2-16.  |
|          | b. Erect pallet support post.   |   |
|          | c. Remove pallet from LM.   |   |

LS006-002-2H  
 LUNAR ROVING VEHICLE  
 OPERATIONS HANDBOOK

LS006-002-2H  
LUNAR ROVING VEHICLE  
OPERATIONS HANDBOOK

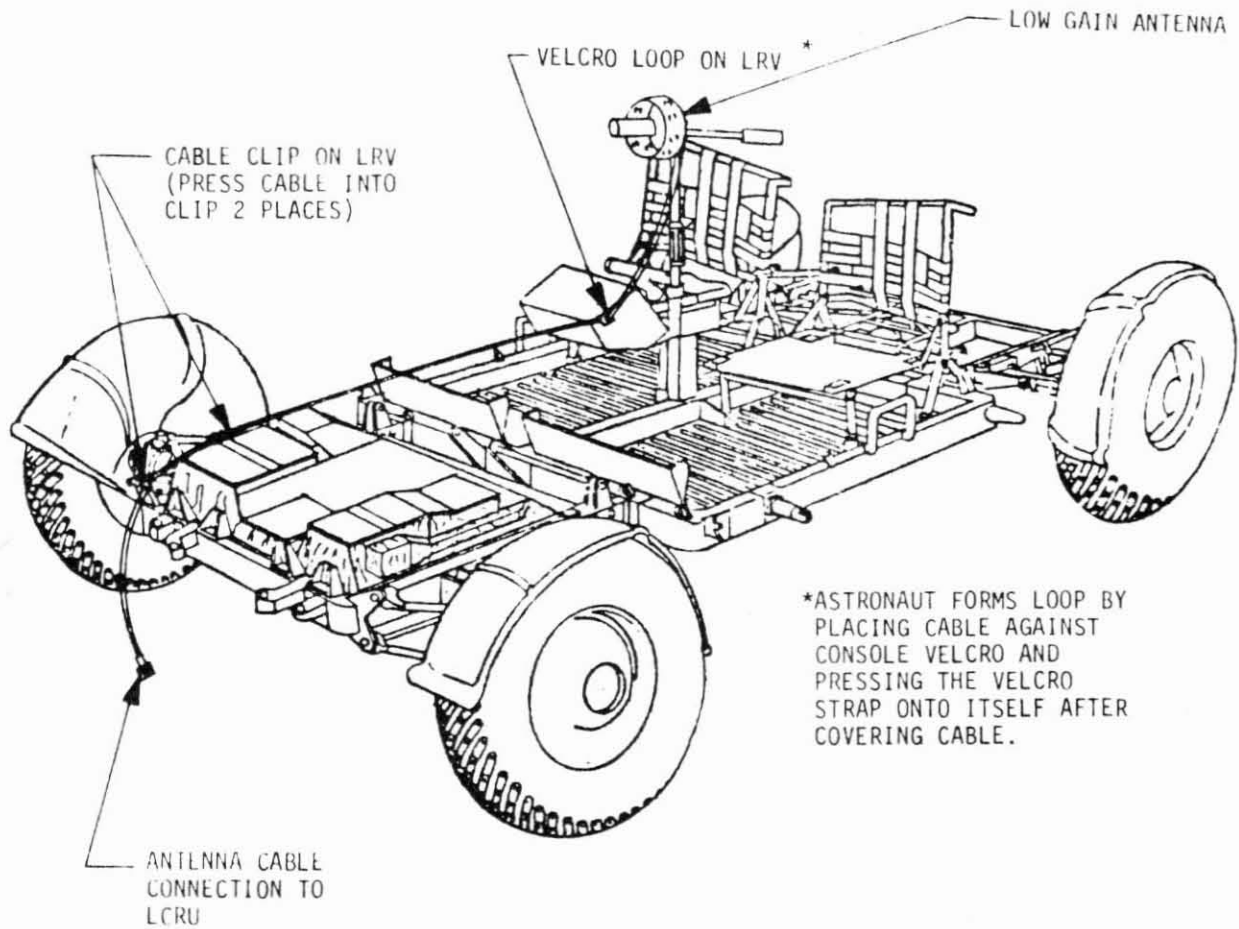

FIGURE 2-15 LCRU LOW GAIN ANTENNA CABLE INSTALLATION ON LUNAR SURFACE



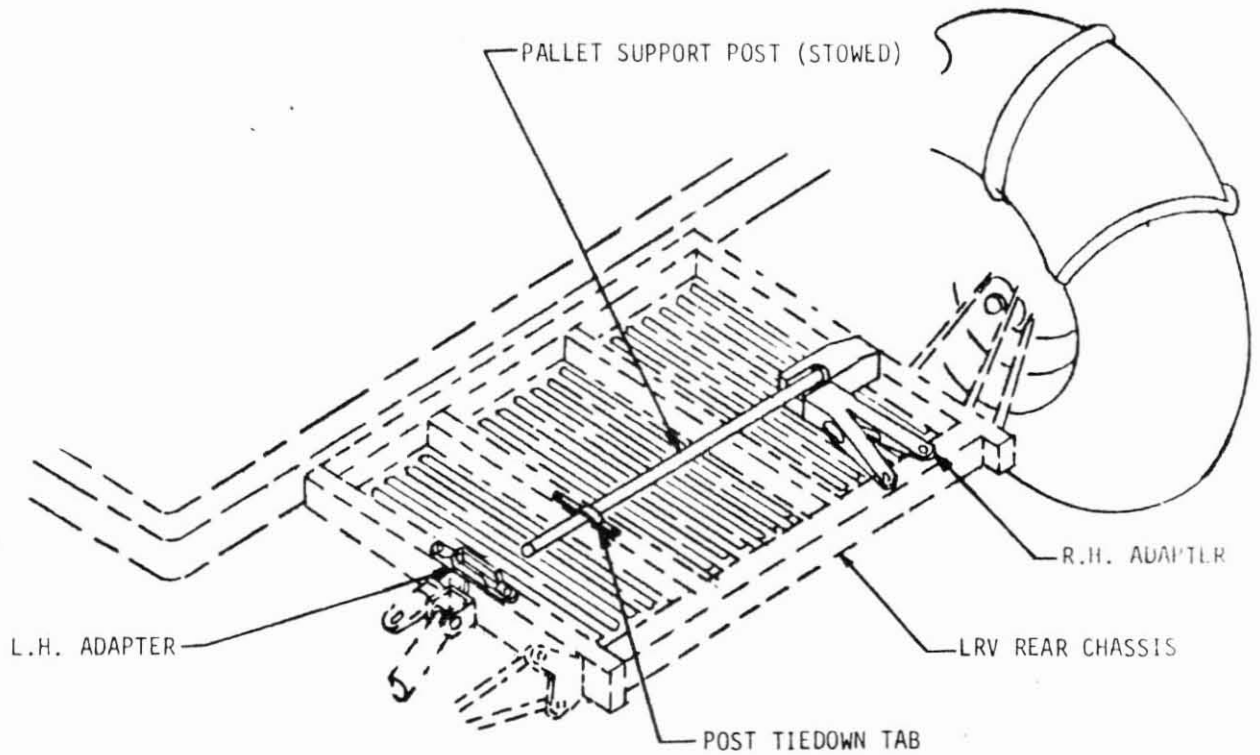

FIGURE 2-16 LRV REAR PAYLOAD PALLET ADAPTERS

Mission J Basic Date 12/4/70 Change Date 4/19/71 Page 2-38

| STA/STEP | PR/CEUPE   | REMARKS      |
|----------|--|--------------|
| 2.3.6    | (Continued)  |              |
| d.       | Connect pallet to pallet support post.   |              |
| e.       | Rotate pallet about support post until pallet locks in pallet adapter on LRV LH aft chassis. | Figure 2-17. |
| 2.3.7    | Buddy SLSS Installation  |              |
| a.       | Remove BSLSS bag from LM.  |              |
| b.       | Release BSLSS support strap on back of right seat.   |              |
| c.       | Feed strap through BSLSS bag handle and secure to PLSS support velcro on front of back seat. | Figure 2-18. |

15006-002-2H  
 LUNAR ROVING VEHICLE  
 OPERATIONS HANDBOOK

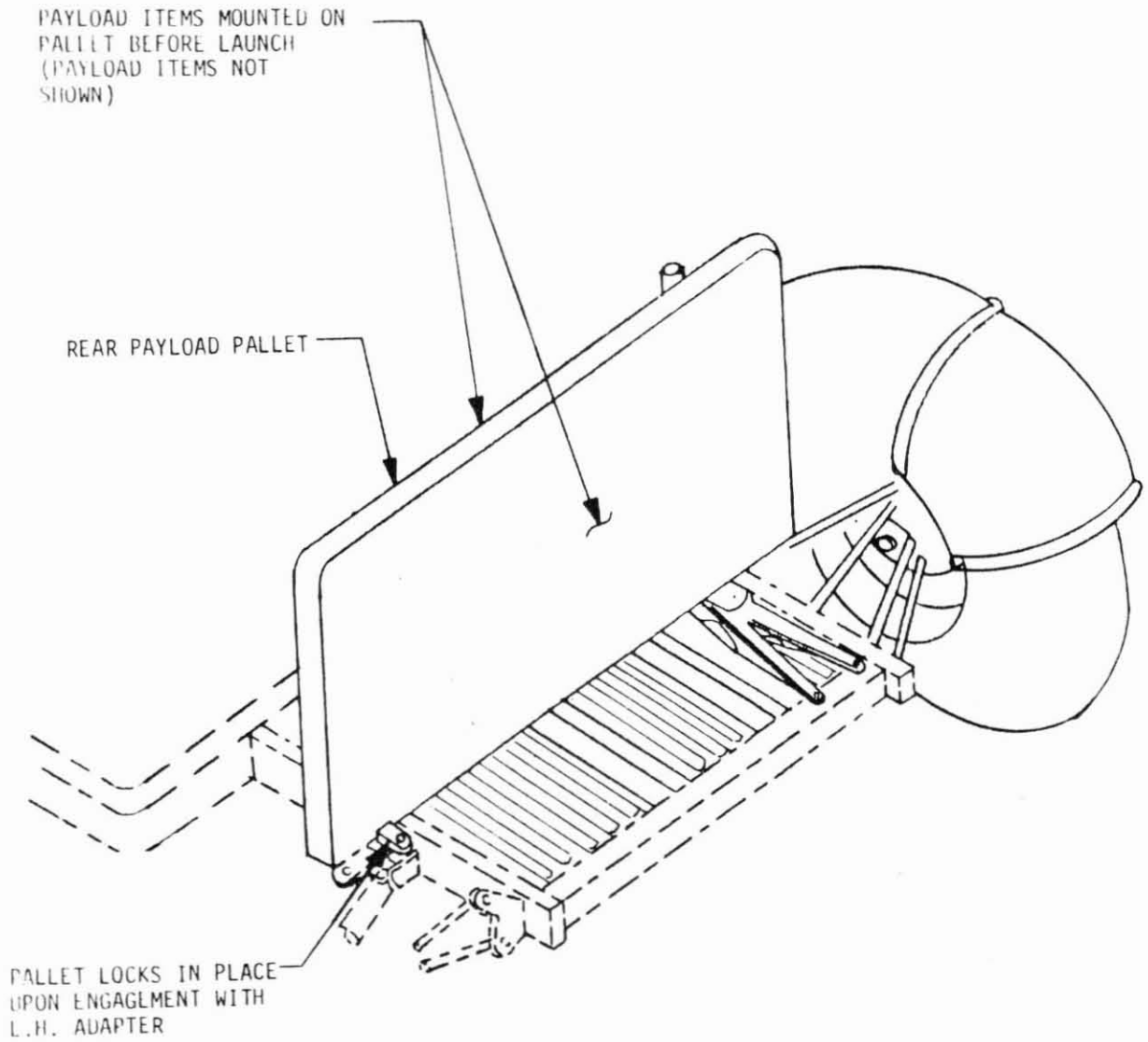

FIGURE 2-17 REAR PAYLOAD PALLET INSTALLED

LS006-002-2H  
LUNAR ROVING VEHICLE  
OPERATIONS HANDBOOK

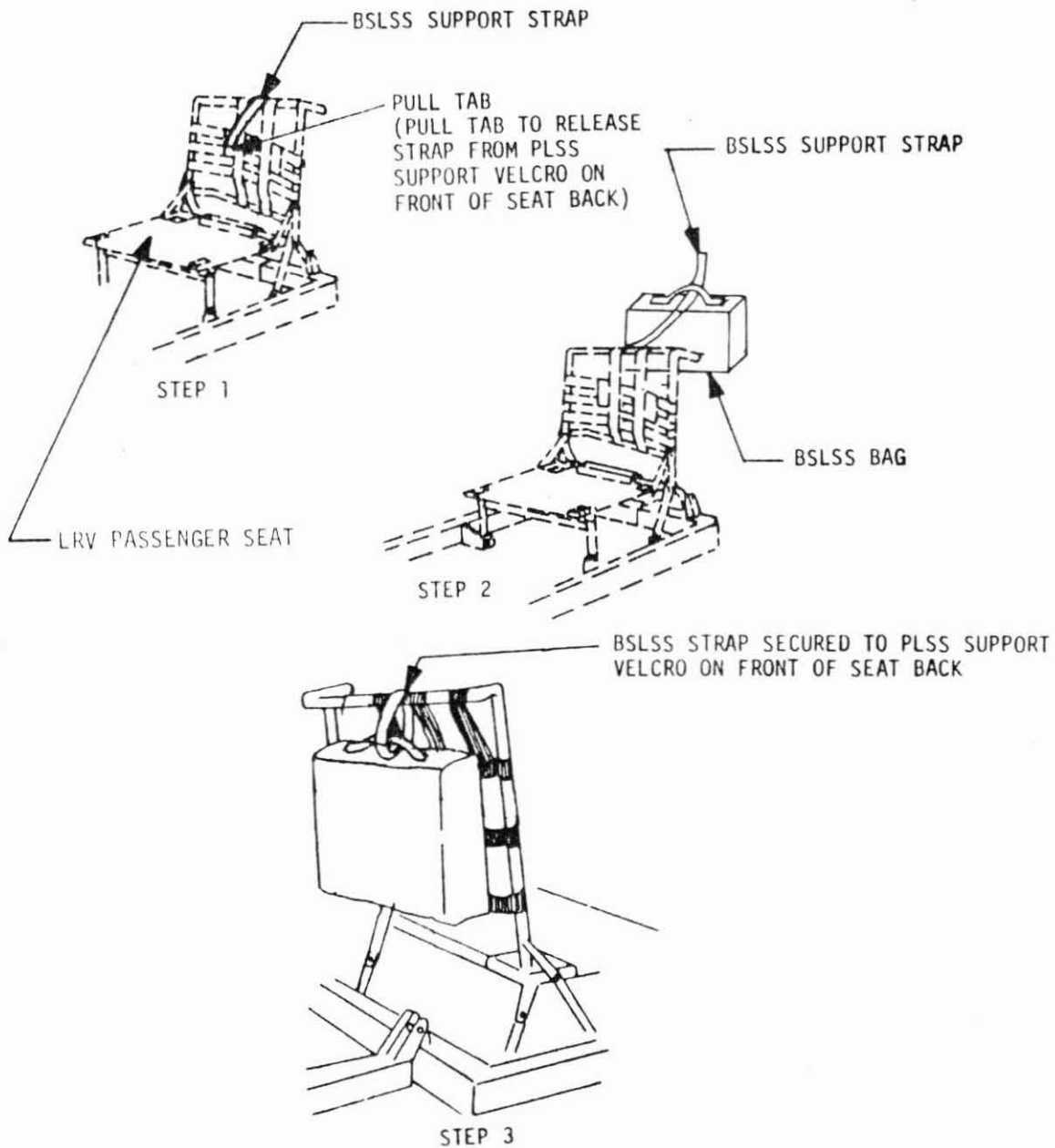

FIGURE 2-18 BUDDY SLSS INSTALLATION

Mission

J

Basic Date

12/4/70

Change Date

4/19/71

Page 2-41

| STA/STEP | PROCEDURE  | REMARKS  |
|----------|--|--|
| 2.4      | <p>PRE SORTIE CHECKOUT AND PREPARATION</p> <p>a. Verify battery and SPU dust covers closed.</p> <p>b. Verify hand controller in parking brake and neutral throttle position and reverse inhibit switch is on (pushed down).</p> <p style="text-align: center;"><b>CAUTION</b></p> <p>Do not grasp the 16 MM Data Acquisition camera staff or low gain antenna staff during ingress. The handholds are designed for ingress by grasping the handhold horizontal and vertical members below the payload staffs.</p> <p>c. LRV driver ingress LRV left seat and fasten seat belt.</p> <p>d. Other crewman ingress LRV, and fasten seat belt.</p> <p style="text-align: center;"><b>CAUTION</b></p> <p>Do not grasp the 16 MM Data Acquisition camera staff or low gain antenna staff during ingress. The handholds are designed for ingress by grasping the handhold horizontal and vertical members below the payload staffs.</p> <p>NOTE: If this is the first LRV sortie and this procedure sequence immediately follows initial payload loading (2.3) and LRV post deployment checkout (2.2), then at this point the C/D panel is in a power down configuration in accordance with step 2.2.ad. If this is the case then step 2.4 need only be a verification as it has been previously accomplished.</p> | <p>Board left seat first and verify parking brake set prior to other crewman boarding. Do not board both seats simultaneously.</p> |

LS006-002-2H  
 LUNAR ROVING VEHICLE  
 OPERATIONS HANDBOOK



Mission

J

Basic Date

12/4/70

Change Date

4/19/71

2-43

| STA/STEP | PROCEDURE  | REMARKS   |
|----------|--|---|
| 2.4      | <p>(Continued)</p> <p style="text-align: center;">CAUTION (Continued)</p> <p>the corresponding drive enable switch is not selected to an active PWM, then full power will be applied to the corresponding drive motor when the hand controller is released from brake position. Should this condition occur the hand controller should be immediately returned to park brake position.</p> <p>q. DRIVE POWER LF Switch - BUS A.</p> <p>r. DRIVE POWER RF Switch - BUS A.</p> <p>s. DRIVE POWER LR Switch - BUS D.</p> <p>t. DRIVE POWER RR Switch - BUS D.</p> <p>u. Drive LRV to level area (<math>\pm 6^\circ</math> pitch) near the LM.</p> <p>v. Deploy SUN SHADOW DEVICE (SSD).</p> <p>w. Deploy Vehicle Attitude Indicator to read roll.</p> <p>x. Park down sun (within <math>\pm 3^\circ</math> per SSD) and level (within <math>\pm 6^\circ</math> roll) and set brake.</p> <p>y. Report sun shadow device readings and LRV pitch and roll angles.</p> <p>z. Fold (or reset) Sun Shadow Device (SSD).</p> | <p>The PWM select switch was verified in "BOTH" position in step 2.2.b.</p> <p>The drive enable switches were set to active PWM positions in steps 2.4.l and 2.4.m.</p> <p>Front wheels operate from Battery No. 1.</p> <p>Rear wheels operate from Battery No. 2.</p> <p>Reset SSD to prevent it from obstructing drivers access to system reset switch.</p> |

L5006-002-2H  
LUNAR ROVING VEHICLE  
OPERATIONS HANDBOOK

| STA/STEP | PROCEDURE  | REMARKS  |
|----------|--|--|
| 2.4      | <p>(Continued)</p> <p>aa. Fold Vehicle Attitude Indicator to drive position (pitch read position).</p> <p>ab. Pull system reset switch from detent move momentarily to reset position and return to off.</p> <p>ac. Verify BEARING, DISTANCE, RANGE Indicators - ZERO.</p> <p>ad. Receive calculated heading from MCC.</p> <div style="text-align: center;"> <p><b>CAUTION</b></p> <p>Continuous torquing of nav gyro shall not exceed 2 minutes of any 7 minute period.</p> </div> <p>ae. Pull GYRO TORQUING Switch from detent and operate to LEFT or RIGHT for proper heading indication, then OFF.</p> <p>af. Report battery 1 and 2 Amp-Hrs.</p> <p>ag. Report battery and drive motor temperatures.</p> <p>ah. Report battery current while vehicle is in motion one time between stops.</p> | <p>Torque LEFT causes heading indication to move CCW. Torque RIGHT causes heading indication to move CW.</p> |

Mission 3  
 Basic Date 12/4/70  
 Change Date 4/19/71  
 Page 2-44





Mission J Basic Date 12/4/70 Change Date 4/19/71 Page 2-46

| STA/STEP | PROCEDURE   | REMARKS |
|----------|---|---------|
| 2.6      | <p data-bbox="464 232 1135 263">LRV CONFIGURATION PRIOR TO LEAVING SCIENCE STOP</p> <p data-bbox="281 294 907 435">a. Align LGA.<br/>b. LCRU Mode Switch - PM1/WB.<br/>c. Board LRV left seat and fasten seatbelt.</p> <p data-bbox="646 445 886 511"><b>CAUTION</b></p> <p data-bbox="464 523 1135 671">Do not grasp the 16 MM Data Acquisition camera staff or low gain antenna staff during ingress. The handholds are designed for ingress by grasping the handhold horizontal and vertical members below the payload staffs.</p> <p data-bbox="281 696 1193 758">d. Verify hand controller in parking brake and neutral throttle position and reverse inhibit switch is on (pushed down).</p> <p data-bbox="281 784 1164 815">e. Other crewman ingress LRV right seat and fasten seat belt.</p> <p data-bbox="654 824 895 890"><b>CAUTION</b></p> <p data-bbox="464 903 1135 1050">Do not grasp the 16 MM Data Acquisition camera staff or low gain antenna staff during ingress. The handholds are designed for ingress by grasping the handhold horizontal and vertical members below the payload staffs.</p> <p data-bbox="281 1075 1218 1138">f. Report Bearing, Distance, Range, Heading, and Battery Amp-Hour indications.</p> <p data-bbox="281 1163 1176 1194">g. Update Nav System to correct for drift, if required by MCC.</p> <p data-bbox="281 1219 667 1251">h. <u>+</u> 15 VDC Switch - PRIM.</p> |         |

LS006-002-2H  
LUNAR ROVING VEHICLE  
OPERATIONS HANDBOOK

Mission J Basic Date 12/4/70 Change Date 4/19/71 Page 2-47

| STA/STEP | PROCEDURE  | REMARKS  |
|----------|--|--|
| 2.6      | (Continued)  |  |
| i.       | STEERING FORWARD Switch - BUS A.   |  |
| j.       | STEERING REAR Switch - BUS D.  |  |
|          | <p style="text-align: center;"><b>CAUTION</b></p> <p>The hand controller should be in park brake position and the drive enable switches must be set to an <u>active</u> PWM prior to setting any drive power switch to an <u>energized</u> bus. If the drive power switch is turned on and the corresponding drive enable switch is not selected to an active PWM, then full power will be applied to the corresponding drive motor when the hand controller is released from brake position. Should this condition occur the hand controller should be immediately returned to park brake position.</p> | <p>The PWM select switch determines which PWM is <u>active</u>. The hand controller was verified set in park brake position in step 2.6.d. The PWM select switch was verified in "BOTH" position in step 2.2.b. The drive enable switches were set to active PWM positions in steps 2.2.p and 2.2.q.</p> |
| k.       | DRIVE POWER LF Switch - BUS A.   |  |
| l.       | DRIVE POWER RF Switch - BUS A.   |  |
| m.       | DRIVE POWER LR Switch - BUS D.   |  |
| n.       | DRIVE POWER RR Switch - BUS D.   |  |

Mission \_\_\_\_\_  
 J \_\_\_\_\_  
 Basic Date 12/4/70 \_\_\_\_\_  
 Change Date 4/19/71 \_\_\_\_\_  
 Page 2-48

| STA/STEP | PROCEDURE  | REMARKS     |
|----------|--|-------------|
| 2.7      | POST SORTIE CHECKOUT<br><br>a. Park LRV cross sun from the right in view of LM windows.<br><br>b. Hand controller in parking brake position, throttle in neutral - SET BRAKE.<br><br>c. Report BEARING, DISTANCE, and RANGE.<br><br>d. Report BAT 1 and BAT 2 AMP-HR.<br><br>e. Report BAT 1 and BAT 2 VOLTS.<br><br>f. BATTERY Switch - AMPS.<br><br>g. Report battery and drive motor temperatures.<br><br>h. DRIVE POWER Switches (4) - OFF.<br><br>i. STEERING Switches (2) - OFF.<br><br>j. + 15 VDC Switch - OFF.<br><br>k. Nav Power Circuit Breaker - OPEN.<br><br>l. BUS A, BUS B, BUS C, BUS D Circuit Breakers - OPEN.<br><br>m. Crewman in right seat release and stow seat belts and egress LRV.<br><br>n. Crewman in left seat release and stow seat belts and egress LRV.<br><br>o. Align HGA.<br><br>p. LCRU mode Switch - TV RMT. | Figure 5-2. |

LS006-002-2H  
 LUNAR ROVING VEHICLE  
 OPERATIONS HANDBOOK

| Mission   | STA/STEP | PROCEDURE   | REMARKS |
|---|----------|---|---------|
| J<br>Basic Date 12/4/70<br>Change Date 4/19/71<br>Page 2-49 | 2.7      | (Continued)<br>q. Open LRV Battery and SPU Dust Covers.<br>r. <u>Prior to LM Ingress</u> - Perform the following:<br>LCRU Power Switch - OFF.<br>Adjust LCRU Thermal Blankets per ground request. |         |

Mission J  
 Basic Date 12/4/70  
 Change Date 4/19/71  
 Page 2-50

| STA/STEP | PROCEDURE   | REMARKS  |
|----------|---|--|
| 2.8      | DISPLAY READING SEQUENCE AND TIME INTERVALS   |  |
| a.       | Report the following displays in the order shown at the time intervals specified below: |  |
|          | <u>DISPLAY</u>  | <u>TIME INTERVAL</u>   |
|          | BEARING<br>and RANGE  | At start of sortie and each 15 minutes or as requested by MCC.   |
|          | AMP-HR and<br>DISTANCE  | At start of sortie and as requested by MCC.  |
|          | BATTERY °F  | At start of sortie and as requested by MCC.  |
|          | AMPS  | Steady state at start of sortie, each 15 minutes when at constant speed, when climbing steep obstacles and when climbing different slopes. |
|          | VOLTS x 1/2   | At start of sortie and as requested by MCC.  |
|          | MOTOR °F  | When requested by MCC.   |
|          | SPEED   | When requested by MCC.   |
|          | PITCH and<br>ROLL   | During Navigation System initialization and update.  |
|          | HEADING   | During Navigation System update  |

---

SECTION 3

MALFUNCTION PROCEDURES

3.0 INTRODUCTION

Malfunction procedures encompass the recognition, diagnosis, and corrective action for system malfunctions. In most cases, the crew is alerted to a malfunction condition by Control and Display Panel meters or indicators. The crew will then locate, correct, or isolate the malfunction and determine its effect on the scheduled mission. In general, the procedures cover significant single failures. Double unrelated failures are not covered to prevent procedures from becoming complex and unmanageable. Malfunctions of a minor nature not requiring detailed procedures are covered in Section 2.

The malfunction procedures are arranged in logic flow diagram format and arranged by symptom routine. A three column format is used for symptom routine logic flow diagrams. A description and use of each of these columns is as follows.

3.1 SYMPTOM COLUMN

The primary purpose of the symptom column is to allow entry into the malfunction procedures. This block explains and qualifies the situation so that the reader understands the symptom or condition that exists. All symptoms are numbered in sequence starting with the number 1.

3.2 PROCEDURE COLUMN

The procedure column presents a step-by-step logic flow diagram of actions and decisions used to isolate or correct a malfunction symptom. This information is presented with several types of logic blocks. These blocks contain the procedures, decisions, and actions to locate and isolate the failure. Remote event symbols are used to reference items in the remarks column or to refer to other procedural steps.

3.3 REMARKS COLUMN

This column will include the following information:

- Amplifying additional remarks related to the symptom.
- Amplifying remarks which relate to a decision and/or action items (e.g., why a step is taken, etc.)
- Explain resultant system status or operational capability after a failure has been identified, i.e., how subsystem is degraded, can degraded subsystem support primary mission, early termination of mission, etc.
- Cautions or warnings, as necessary, to cover conditions that may exist because of a failure.

LS006-002-2H  
LUNAR ROVING VEHICLE  
OPERATIONS HANDBOOK

---

| <u>MALFUNCTION PROCEDURES</u>   | <u>NO.</u> | <u>PAGE</u> |
|---|------------|-------------|
| CAUTION AND WARNING FLAG ACTUATES   | 1          | 3-3         |
| EITHER BATTERY TEMP > 125°F   | 2          | 3-3         |
| ONE DRIVE MOTOR TEMP > 400°F  | 3          | 3-4         |
| ABNORMAL IMBALANCE BETWEEN BAT 1 AND BAT 2<br>AMPS (VEHICLE ACCELERATION NORMAL OR LOW) | 4          | 3-4         |
| FRONT (REAR) WHEELS DO NOT RESPOND TO<br>HAND CONTROLLER STEERING COMMANDS              | 5          | 3-5         |
| ONE OR MORE WHEELS DRIVE WHILE IN<br>NEUTRAL  | 6          | 3-6         |
| LOSS OF DRIVE FROM ONE OR TWO WHEELS<br>(COMMANDED ACCELERATION ABNORMALLY LOW)         | 7          | 3-7         |
| COMMANDED VEHICLE SPEED ABNORMALLY HIGH<br>(SPEED NOT VARIABLE ON ONE OR MORE WHEELS)   | 8          | 3-8         |
| LOSS OF DRIVE FROM ALL WHEELS   | 9          | 3-9         |
| BRAKE WILL NOT RELEASE  | 10         | 3-10        |
| LOSS OF VOICE COMM WITH MSFN  | 11         | 3-11        |

TABLE 3-1 MALFUNCTION PROCEDURES



LS006-002-211  
LUNAR ROVING VEHICLE  
OPERATIONS HANDBOOK

| SYMPTOM  | PROCEDURE  | REMARKS |     |  |     |  |
|--|--|---------|-----|--|-----|--|
| <p>1</p> <div style="border: 1px solid black; padding: 5px; width: fit-content; margin: 5px auto;">CAUTION AND WARNING FLAG ACTUATES</div> | <div style="display: flex; justify-content: space-between;"> <div style="width: 45%;"> <p>1</p> <div style="border: 1px solid black; padding: 5px; width: fit-content; margin: 5px auto;">RESET C&amp;W FLAG</div> <p>2</p> <div style="border: 1px solid black; padding: 5px; width: fit-content; margin: 5px auto;">EITHER BATTERY TEMP &gt;125°F?</div> <p style="text-align: center;">NO</p> <p>3</p> <div style="border: 1px solid black; padding: 5px; width: fit-content; margin: 5px auto;">ANY MOTOR TEMP &gt;400°F?</div> <p style="text-align: center;">NO</p> <p>4</p> <div style="border: 1px solid black; padding: 5px; width: fit-content; margin: 5px auto;">PROBABLE C&amp;W SYSTEM MAL-FUNCTION</div> </div> <div style="width: 45%;"> <p>SYMPTOM</p> <table border="1" style="width: 100%; border-collapse: collapse;"> <tr><td style="width: 50%;">2</td><td style="width: 50%;">3-3</td></tr> </table> <p>SYMPTOM</p> <table border="1" style="width: 100%; border-collapse: collapse;"> <tr><td style="width: 50%;">3</td><td style="width: 50%;">3-4</td></tr> </table> </div> </div>   | 2       | 3-3 | 3  | 3-4 | <p>1</p> <p>IF C&amp;W FLAG CONTINUES TO ACTUATE OR WILL NOT RESET, LEAVE FLAG UP AND IGNORE IT.</p> |
| 2  | 3-3  |         |     |  |     |  |
| 3  | 3-4  |         |     |  |     |  |
| <p>2</p> <div style="border: 1px solid black; padding: 5px; width: fit-content; margin: 5px auto;">EITHER BATTERY TEMP &gt;125°F</div>     | <div style="display: flex; justify-content: space-between;"> <div style="width: 45%;"> <p>1</p> <div style="border: 1px solid black; padding: 5px; width: fit-content; margin: 5px auto;">VOLTS/AMPS NORMAL?</div> <p style="text-align: center;">NO</p> <p>SYMPTOM</p> <table border="1" style="width: 100%; border-collapse: collapse;"> <tr><td style="width: 50%;">4</td><td style="width: 50%;">3-4</td></tr> </table> <p>2</p> <div style="border: 1px solid black; padding: 5px; width: fit-content; margin: 5px auto;">INFORM MCC OF AMP-HOUR READINGS AND REMOVE LOADS FROM AFFECTED BATTERY</div> <p>3</p> <div style="border: 1px solid black; padding: 5px; width: fit-content; margin: 5px auto;">BATTERY TEMP INDICATES GRADUAL COOLDOWN?</div> <p style="text-align: center;">NO</p> <p>7</p> <div style="border: 1px solid black; padding: 5px; width: fit-content; margin: 5px auto;">OPEN CKT BRKRS AAC THEN CLOSE THEM</div> <p>8</p> <div style="border: 1px solid black; padding: 5px; width: fit-content; margin: 5px auto;">C&amp;W FLAG ACTUATE?</div> <p style="text-align: center;">NO</p> <p>9</p> <div style="border: 1px solid black; padding: 5px; width: fit-content; margin: 5px auto;">CONTINUE MISSION, MONITOR A-H READINGS, TRANSFER LOADS TO OTHER BATTERY</div> </div> <div style="width: 45%;"> <p>1</p> <div style="border: 1px solid black; padding: 5px; width: fit-content; margin: 5px auto;">AT NEXT STOP: ORIENT LRV CROSS SUN FROM RIGHT FAISE BATTERY COVERS, POWER DOWN LRV EXCEPT FOR NAV SYSTEM, MONITOR BATTERY TEMP.</div> <p>3</p> <div style="border: 1px solid black; padding: 5px; width: fit-content; margin: 5px auto;">BATTERY THERMAL CAPABILITY DEGRADED</div> <p>4</p> <div style="border: 1px solid black; padding: 5px; width: fit-content; margin: 5px auto;">PROBABLE BATTERY TEMP SENSOR FAILURE</div> <p>8</p> <div style="border: 1px solid black; padding: 5px; width: fit-content; margin: 5px auto;">PROBABLE INTERNAL BATTERY SHORT OR CONNECTOR SHORT</div> </div> </div> | 4       | 3-4 | <p>1</p> <p>ALL CKT BREAKERS SHOULD REMAIN CLOSED. BATTERY COVERS WILL AUTOMATICALLY CLOSE WHEN PROPER TEMP LEVELS ARE REACHED.</p> <p>2</p> <p>COOLDOWN RATE IN ACCORDANCE WITH APPENDIX A.</p> <p>3</p> <p>BATTERY MAY BE UTILIZED WHEN TEMPERATURE PERMITS</p> <p>4</p> <p>DISREGARD TEMPERATURE INDICATION. MONITOR A-H, VOLTS/AMPS.</p> <p>5</p> <p>DEGRADED MISSION.</p> |     |  |
| 4  | 3-4  |         |     |  |     |  |
| SYMPTOM  | PROCEDURE  | REMARKS |     |  |     |  |

TABLE 3-2. MALFUNCTION LOGIC FLOW DIAGRAM

LS006-007-211  
LUNAR ROVING VEHICLE  
OPERATIONS HANDBOOK

| SYMPTOM   | PROCEDURE   | REMARKS  |
|---|---|--|
| <p>3</p> <p>ONE DRIVE MOTOR TEMP <math>&gt;400^{\circ}\text{F}</math></p>                             | <pre> graph TD     S1[1 STOP VEHICLE FOR AFFECTED WHEEL:<br/>- DRIVE PWR OFF<br/>- DRIVE ENABLE OFF] --&gt; S2[2 DECOUPLE AFFECTED WHEEL, RESUME SORTIE]     S2 --&gt; S3[3 MOTOR TEMP INDICATE GRADUAL COOLDOWN?]     S3 -- YES --&gt; S4[4 MOTOR THERMAL CAPABILITY DEGRADED]     S3 -- NO --&gt; S5[5 MOTOR TEMP SENSOR FAILURE]     </pre>  | <p>1 DRIVE AND BRAKING IN ACCORDANCE WITH APPENDIX A. IF WHEEL IS R.R., SPEED METER WILL NOT FUNCTION.</p> <p>2 IF REQUIRED, WHEEL CAN BE RECOUPLED WHEN TEMP. PERMITS.</p> <p>3 WHEEL CAN BE RECOUPLED AT CREW OPTION. TEMP INDICATION SHOULD BE DISREGARDED.</p> |
| <p>4.</p> <p>ABNORMAL IMBALANCE BETWEEN BAT 1 AND BAT 2 AMPS (VEHICLE ACCELERATION NORMAL OR LOW)</p> | <pre> graph TD     S1[1 ONE AT A TIME: DRIVE POWER SWITCHES (4) OFF, THEN ORIGINAL POSITION] --&gt; S2{2 AMPS RETURN TO NORMAL WITH ANY DRIVE POWER SWITCH OFF?}     S2 -- YES --&gt; S3[3 SHORT IN DRIVE MOTOR OR DRIVE PWR CIRCUITRY]     S2 -- NO --&gt; S4[4 DRIVE ENABLE SWITCHES (4) - PWM 1]     S4 --&gt; S5{5 AMPS NORMAL?}     S5 -- YES --&gt; S6[6 PWM 2 FAILURE]     S5 -- NO --&gt; S7[7 DRIVE ENABLE SWITCHES (4) - PWM 2]     S7 --&gt; S8{8 AMPS NORMAL?}     S8 -- YES --&gt; S9[9 PWM 1 FAILURE]     S8 -- NO --&gt; S10[10]     S3 --&gt; S11[3 AFFECTED WHEEL: DRIVE PWR SW OFF<br/>DRIVE ENABLE SW OFF<br/>DECOUPLE WHEEL]     S6 --&gt; S12[6 PWM SELECT SWITCH - PWM 1]     S9 --&gt; S13[9 PWM SELECT SW - PWM 2]     </pre> | <p>1 IF ABNORMAL CONDITION EXISTS ONLY WHEN LRV IS IN MOTION, THIS STEP MUST BE PERFORMED WITH LRV IN MOTION</p> <p>2 DO NOT ALLOW DRIVE ENABLE SWITCH TO REMAIN IN "OFF" POSITION WHILE SWITCHING, OR FULL POWER TO AFFECTED MOTOR WILL RESULT.</p>               |
| SYMPTOM   | PROCEDURE   | REMARKS  |

TABLE 3-2. MALFUNCTION LOGIC FLOW DIAGRAM (CONTINUED)

| SYMPTOM   | PROCEDURE  | REMARKS   |
|---|--|---|
| <p>4 (CONTINUED)</p>  | <pre> graph TD     7[7] --&gt; 10[10<br/>DR PWP SW (4) -<br/>ALTERNATE<br/>POSITION<br/>AMPS NORMAL?]     10 -- YES --&gt; 12[12<br/>OPEN IN DRIVE<br/>MOTOR POWER<br/>CIRCUITRY FOR<br/>ONE BUS]     10 -- NO --&gt; 11[11<br/>PROBABLE OPEN<br/>IN DRIVE MOTOR<br/>POWER CIRCUITRY]     11 --&gt; 13[13<br/>DR PWR SW (4) -<br/>OFF, THEN BACK<br/>TO ORIGINAL<br/>POSITION ONE AT<br/>A TIME TO<br/>ISOLATE MOTOR<br/>NOT DRAWING AMPS]     13 --&gt; 14{14<br/>FAILED MOTOR<br/>ISOLATED?}     14 -- YES --&gt; 15[15<br/>AFFECTED WHEEL:<br/>- DRIVE PWR SW -<br/>OFF<br/>- DRIVE ENABLE SW<br/>- OFF<br/>- DECOUPLE WHEEL]     14 -- NO --&gt; 14     14 --&gt; 14     14 --&gt; 14     </pre> |   |
| <p>5</p> <p>FRONT (REAR) WHEELS DO NOT RESPOND TO HAND CONTROLLER STEERING COMMANDS</p> | <pre> graph TD     1[1<br/>FORWARD (REAR)<br/>STEERING SWITCH -<br/>ALTERNATE<br/>POSITION] --&gt; 2{2<br/>DO FRONT (REAR)<br/>WHEELS RESPOND<br/>TO HAND<br/>CONTROLLER?}     2 -- YES --&gt; 2[2<br/>LOSS OF FORWARD<br/>(REAR) REDUNDANT<br/>STEERING CIRCUIT]     2 -- NO --&gt; 3[3<br/>FORWARD (REAR)<br/>STEERING INOP]     3 --&gt; 4[4<br/>FORWARD (REAR)<br/>STEERING SWITCH -<br/>OFF<br/>- DECOUPLE FWD<br/>(REAR) STEERING<br/>- CENTER &amp; LOCK<br/>FWD (REAR)<br/>WHEELS]     </pre>  | <p>①</p> <p>TO REDUCE REQUIRED FORCE, STRAIGHTEN WHEELS BY PUSHING ON WHEEL WITH SMALLER TURNING ANGLE, (I.E. IF WHEELS ARE TURNED TO RIGHT, PUSH ON LEFT WHEEL TO STRAIGHTEN).</p> <ul style="list-style-type: none"> <li>- HAND TOOL PRY FORCE MAY BE REQUIRED</li> <li>- SIMULTANEOUS PULL FORCE MAY BE REQUIRED ON DECOUPLING RING</li> </ul> <p>DEGRADED OPERATION - STEERING RADIUS INCREASED IN ACCORDANCE WITH APPENDIX A</p> |
| SYMPTOM   | PROCEDURE  | REMARKS   |

TABLE 3-2. MALFUNCTION LOGIC FLOW DIAGRAM (CONTINUED)

LS006-002-2H  
LUNAR ROVING VEHICLE  
OPERATIONS HANDBOOK

| SYMPTOM   | PROCEDURE   | REMARKS   |
|---|---|---|
| <p>6</p> <p>ONE OR MORE WHEELS DRIVE WHILE IN NEUTRAL</p> | <pre> graph TD     S6[6 ONE OR MORE WHEELS DRIVE WHILE IN NEUTRAL] --&gt; P1[1 STOP LRV DRIVE ENABLE SW (4) - PWM 1]     P1 --&gt; D1{TRACTION DRIVE NORMAL?}     D1 -- YES --&gt; R2[2 PWM 2 OUTPUT CIRCUITRY OR DRIVE ENABLE SWITCH FAILURE]     D1 -- NO --&gt; P3[3 DRIVE ENABLE SW (4) - PWM 2]     P3 --&gt; D2{TRACTION DRIVE NORMAL?}     D2 -- YES --&gt; R4[4 PWM 1 OUTPUT CIRCUITRY OR DRIVE ENABLE SWITCH FAILURE]     D2 -- NO --&gt; P5[5 DRIVE PWR SW (4) - OFF, THEN BACK TO ORIGINAL POSITION ONE AT A TIME TO ISOLATE ABNORMAL WHEEL]     P5 --&gt; D3{ONLY ONE WHEEL AFFECTED?}     D3 -- YES --&gt; R6[6 DRIVE CONTROL ELECTRONICS FAILURE]     D3 -- NO --&gt; P7[7 OPERATE LRV BY RELEASING BRAKE MOMENTARILY TO NEUTRAL TO OBTAIN SPEED AND THEN RETURN IT TO BRAKE IN A CYCLIC MANNER]     R6 --&gt; P8[8 AFFECTED WHEEL: - DRIVE PWR SW - OFF, - DRIVE ENABLE SW - OFF, - DECOUPLE WHEEL]     </pre> | <p>1 DO NOT ALLOW DRIVE ENABLE SWITCH TO REMAIN IN OFF POSITION WHILE SWITCHING, OR FULL POWER TO AFFECTED MOTOR WILL RESULT</p> <p>2 IF DECOUPLED WHEEL IS RR, SPEED METER WILL NOT FUNCTION DRIVE AND BRAKING IN ACCORDANCE WITH APPENDIX A</p> |
| SYMPTOM   | PROCEDURE   | REMARKS   |

TAB 3-2. MALFUNCTION LOGIC FLOW DIAGRAM (CONTINUED)

L5006-002-2F  
LUNAR ROVING VEHICLE  
OPERATIONS HANDBOOK

| SYMPTOM  | PROCEDURE  | REMARKS  |
|--|--|--|
| <p>7</p> <p>LOSS OF DRIVE FROM ONE OR TWO WHEELS (COMMANDED ACCELERATION ABNORMALLY LOW)</p> | <pre> graph TD     S7[7: LOSS OF DRIVE FROM ONE OR TWO WHEELS (COMMANDED ACCELERATION ABNORMALLY LOW)] --&gt; B1[1: AFFECTED WHEELS: DRIVE ENABLE SW - ALTERNATE POSITION]     B1 --&gt; D1{WHEEL DRIVE OPERABLE?}     D1 -- YES --&gt; B2[2: PWM CIRCUITRY OR DRIVE ENABLE SWITCH FAILURE]     D1 -- NO --&gt; B3[3: AFFECTED WHEEL(S) DRIVE POWER SW - ALTERNATE POSITION]     B3 --&gt; D2{WHEEL DRIVE OPERABLE?}     D2 -- YES --&gt; B4[4: DRIVE PWR CIRCUITRY FAILURE]     D2 -- NO --&gt; B5[5: DRIVE SYSTEM FOR AFFECTED WHEEL INOP]     B5 --&gt; B6[6: AFFECTED WHEEL: DRIVE POWER OFF DRIVE ENABLE OFF DECOUPLE WHEEL]     </pre> | <p>① DO NOT ALLOW DRIVE ENABLE SWITCH TO REMAIN IN OFF POSITION WHILE SWITCHING OR FULL POWER TO AFFECTED MOTOR WILL RESULT</p> <p>② IF DECOUPLED WHEEL IS RR, SPEED INDICATOR WILL NOT FUNCTION<br/>DRIVE AND BRAKING IN ACCORDANCE WITH APPENDIX A</p> |
| SYMPTOM  | PROCEDURE  | REMARKS  |

TABLE 3-2. MALFUNCTION LOGIC FLOW DIAGRAM (CONTINUED)

| SYMPTOM   | PROCEDURE  | REMARKS  |
|---|--|--|
| <p>8<br/>COMMANDED VEHICLE SPEED ABNORMALLY HIGH (SPEED NOT VARIABLE ON ONE OR MORE WHEELS)</p> | <pre> graph TD     Start[1] --&gt; Q1{TRACTION DRIVE NORMAL?}     Q1 -- YES --&gt; R2[PWM 2 CIRCUITRY OR DRIVE ENABLE SWITCH FAILURE]     Q1 -- NO --&gt; Q2{TRACTION DRIVE NORMAL?}     Q2 -- YES --&gt; R4[PWM 1 CIRCUITRY OR DRIVE ENABLE SWITCH FAILURE]     Q2 -- NO --&gt; Q3{ONLY ONE WHEEL AFFECTED?}     Q3 -- YES --&gt; R6[DRIVE CONTROL ELECTRONICS FAILURE]     Q3 -- NO --&gt; R7[OPERATE LRV BY ACTUATING THE HAND CONTROLLER THROTTLE MOMENTARILY TO FORWARD TO OBTAIN SPEED AND THEN RETURN IT TO NEUTRAL OR BRAKE IN A CYCLIC MANNER]     R6 --&gt; R8[AFFECTED WHEEL: - DRIVE PWR SW - OFF, - DRIVE ENABLE SW - OFF, - DECOUPLE WHEEL]     </pre> | <p>1<br/>DO NOT ALLOW DRIVE ENABLE SWITCH TO REMAIN IN OFF POSITION WHILE SWITCHING, OR FULL POWER TO AFFECTED MOTOR WILL RESULT</p> <p>CAUTION SHOULD BE TAKEN SINCE VEHICLE MAY TEND TO ACCELERATE TO MAX SPEED IF SELECTED PWM IS DEFECTIVE</p> <p>2<br/>IF DECOUPLED WHEEL IS RR, SPEED METER WILL NOT FUNCTION</p> <p>DRIVE AND BRAKING IN ACCORDANCE WITH APPENDIX A</p> |
| SYMPTOM   | PROCEDURE  | REMARKS  |

TABLE 3-2. MALFUNCTION LOGIC FLOW DIAGRAM (CONTINUED)

LS006-002-2H  
LUNAR ROVING VEHICLE  
OPERATIONS HANDBOOK

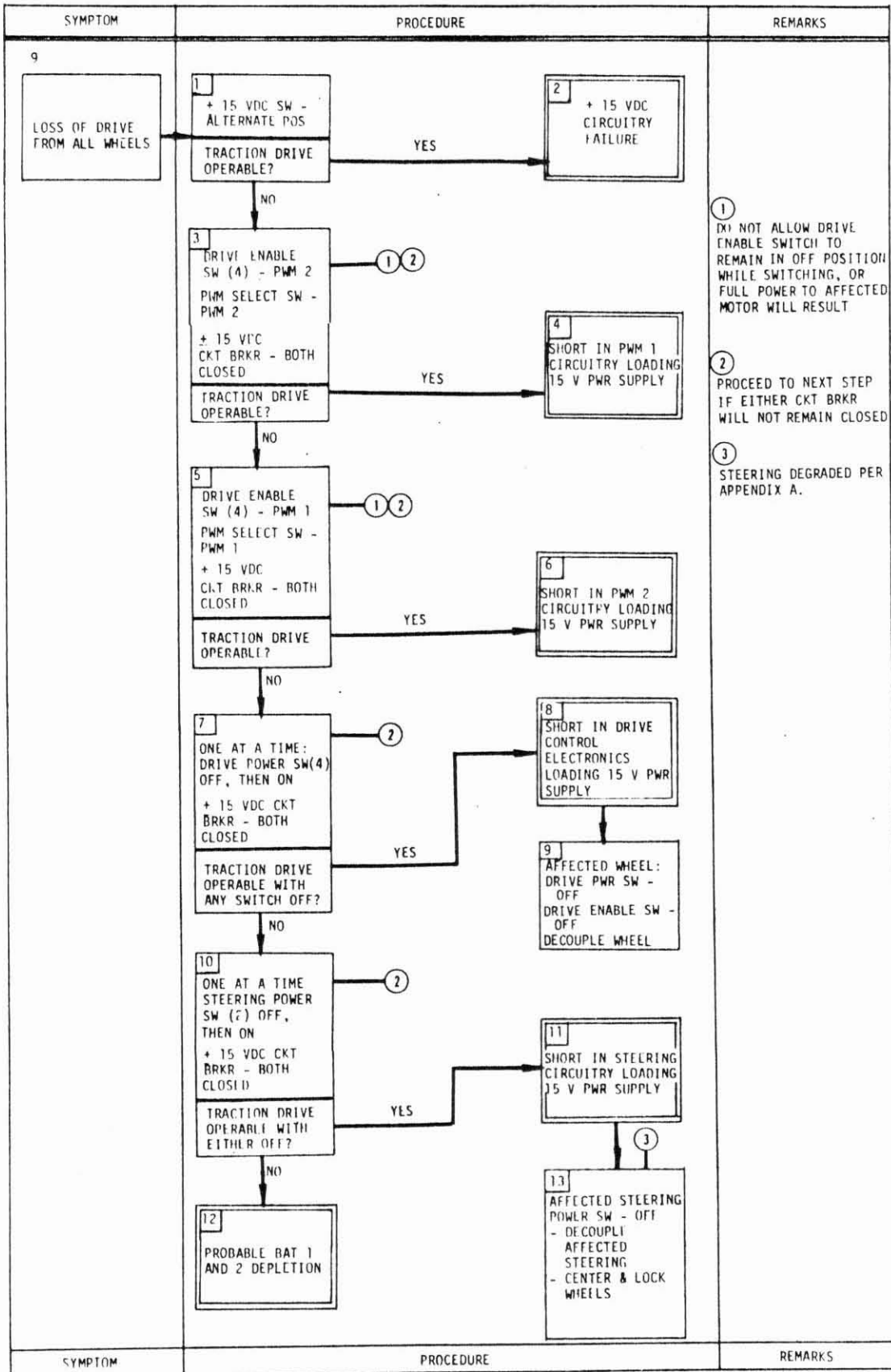

TABLE 3-2. MALFUNCTION LOGIC FLOW DIAGRAM (CONTINUED)

LS006-002-2H  
LUNAR ROVING VEHICLE  
OPERATIONS HANDBOOK

| SYMPTOM  | PROCEDURE  | REMARKS   |
|--|--|---|
| <p>10</p> <div data-bbox="232 265 410 399" style="border: 1px solid black; padding: 5px; width: fit-content;">           BRAKE WILL NOT RELEASE         </div> | <div data-bbox="868 265 1047 399" style="border: 1px solid black; padding: 5px; width: fit-content; margin-left: auto;"> <sup>1</sup><br/>           BINDING, JAMMING OR OTHER MECHANISM FAILURE         </div> <div data-bbox="868 472 1056 607" style="border: 1px solid black; padding: 5px; width: fit-content; margin-left: auto; margin-top: 20px;"> <sup>2</sup><br/>           AFFECTED WHEEL:<br/>           - DRIVE PWR OFF<br/>           - DRIVE ENABLE OFF<br/>           - DECOUPLE WHEEL         </div> | <div data-bbox="1103 430 1292 621" style="border: 1px solid black; padding: 5px; width: fit-content; margin-left: auto;"> <sup>1</sup><br/>           DRIVE AND BRAKING IN ACCORDANCE WITH APPENDIX A<br/><br/>           IF AFFECTED WHEEL IS RR, SPEED METER WILL NOT FUNCTION         </div> |
| SYMPTOM  | PROCEDURE  | REMARKS   |

TABLE 3-2. MALFUNCTION LOGIC FLOW DIAGRAM (CONTINUED)



LS006-002-2H  
LUNAR ROVING VEHICLE  
OPERATIONS HANDBOOK

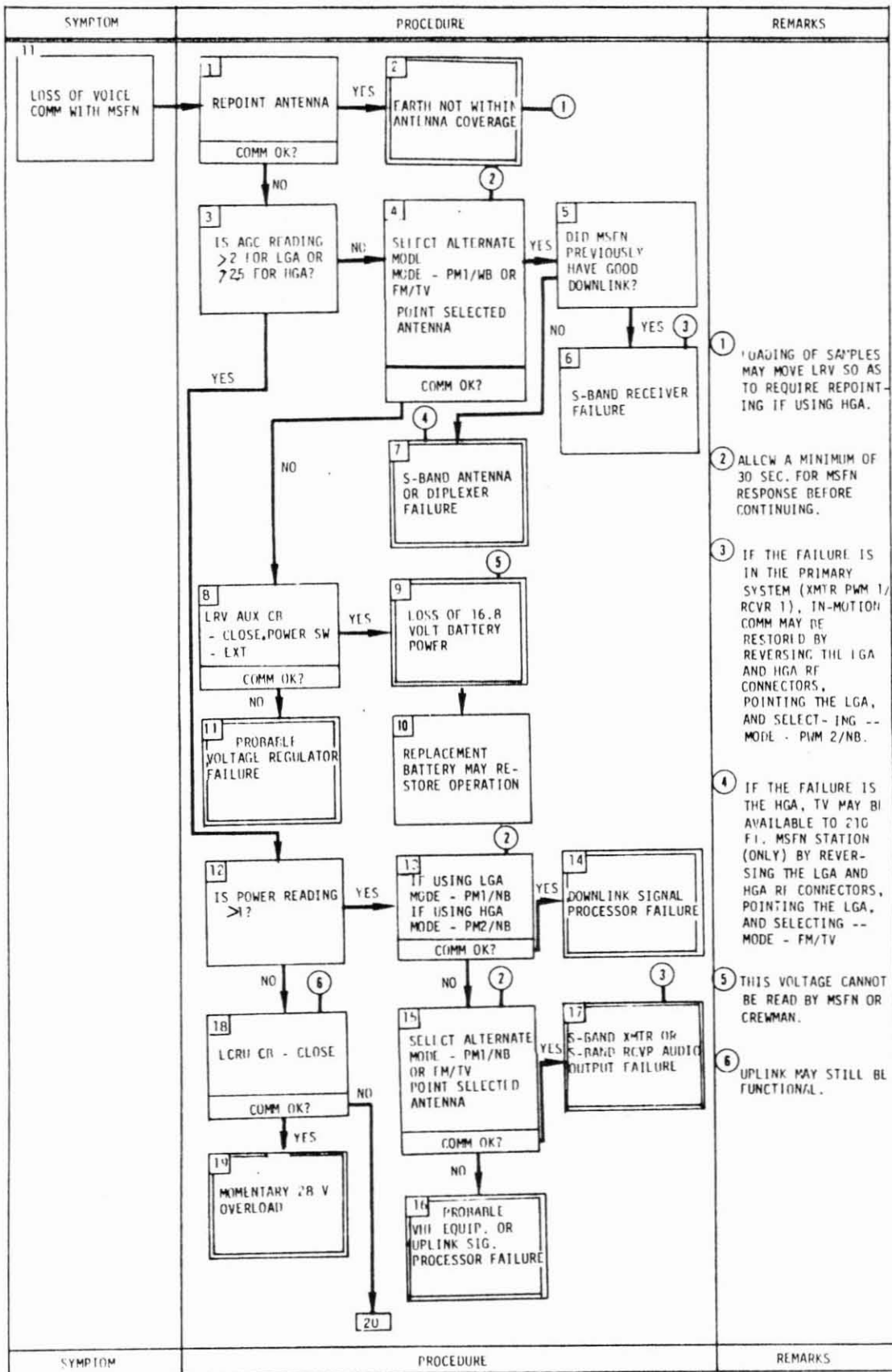

TABLE 3-2. MALFUNCTION LOGIC FLOW DIAGRAM (CONTINUED)

LS000-012-21  
LUNAR ROVING VEHICLE  
OPERATIONS HANDBOOK

| SYMPTOM               | PROCEDURE   | REMARKS |
|-----------------------|---|---------|
| <p>11 (CONTINUED)</p> | <pre> graph TD     18[18] --&gt; 20{20<br/>DID CB REMAIN<br/>CLOSED?}     20 -- YES --&gt; 26{26<br/>LRV AUX CG.<br/>- CLOSE<br/>POWER SW - EXT<br/>COMM OK?}     20 -- NO --&gt; 21{21<br/>SELECT ALTERNATE<br/>MODE - MODE PM1/<br/>WE OR FM/TV<br/>LCRU CG - CLOSE<br/>DID CB REMAIN<br/>CLOSED?}     26 -- YES --&gt; 28{28<br/>LOSS OF 28 VOLT<br/>BATTERY POWER}     26 -- NO --&gt; 27{27<br/>PROBABLE<br/>LRV 28 VOLT<br/>WIRING OPEN<br/>CIRCUIT}     28 --&gt; 29{29<br/>REPLACEMENT<br/>BATTERY<br/>MAY RESTORE<br/>OPERATION}     21 -- YES --&gt; 23{23<br/>POINT SELECTED<br/>ANTENNA<br/>COMM OK?}     21 -- NO --&gt; 22{22<br/>SHORT IN 28<br/>VOLT CIRCUIT}     23 -- YES --&gt; 24{24<br/>S-BAND XMTR<br/>SHORTED}     23 -- NO --&gt; 25{25<br/>PROBABLE DAMAGE<br/>TO MODE SWITCH}     22 --&gt; 6((6))     </pre> |         |
| SYMPTOM               | PROCEDURE   | REMARKS |

TABLE 3-2. MALFUNCTION LOGIC FLOW DIAGRAM (CONTINUED)

LS006-002-2H  
LUNAR ROVING VEHICLE  
OPERATIONS HANDBOOK

---

SECTION 4

AUXILIARY EQUIPMENT

4.0 INTRODUCTION

This section contains the LRV and 1G Trainer auxiliary equipment which includes provisions for transporting miscellaneous equipment for support of lunar activities including experiments, communications and photograph.

4.1 FORWARD CHASSIS PAYLOAD PROVISIONS

The forward chassis contains the equipment necessary to transport the LCRU, the high gain antenna, and the ground controlled television camera assembly (GCTA).

4.1.1 Lunar Communications Relay Unit (LCRU)

The LCRU is mounted in the two inboard receptacles on the forward chassis forward frame member as shown in figure 4-1. To conserve crew time on the lunar surface, the two LCRU support posts are installed in these receptacles at KSC before securing the LRV in the LM. In addition, the LRV/LCRU power cable is also connected to the LRV auxiliary connector before launch. The LCRU support posts and LRV/LCRU power cable are stowed on the LRV as shown in figure 4-2.

4.1.2 High Gain Antenna and GCTA

The high gain antenna is secured to the left outboard receptacle on the forward chassis forward frame member (figure 4-1). This receptacle is identical to the one on the right outboard side for the GCTA.

Provisions for securing the LCRU low gain antenna coax cable to the LRV are shown on figure 4-3.

4.2 CENTER CHASSIS PAYLOAD PROVISIONS

The center chassis has provisions to carry auxiliary equipment on the inboard handholds, under the crew seats and on the chassis floor.

4.2.1 Inboard Handhold Payload Receptacle

The inboard handholds are provided with receptacles for supporting the 16 mm Data Acquisition Camera and low gain antenna as shown in figure 4-4.

4.2.2 Under-Seat Stowage

One collapsible stowage bag is provided under each seat for transporting miscellaneous payload items. These bags are installed on the LRV before launch.

LS006-002-2H  
LUNAR ROVING VEHICLE  
OPERATIONS HANDBOOK

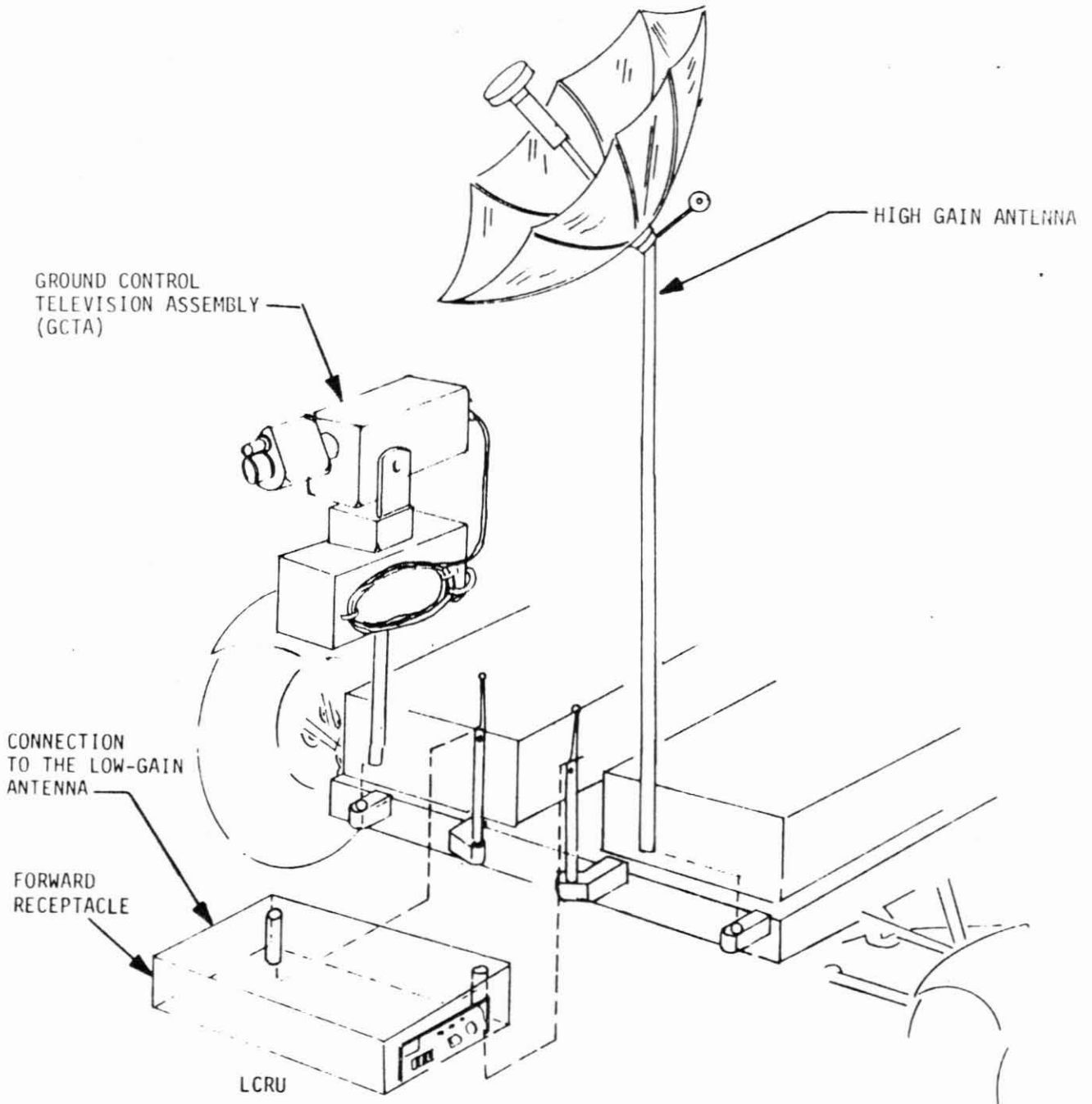

FIGURE 4-1. LCRU, HIGH GAIN ANTENNA, TV CAMERA INSTALLATION

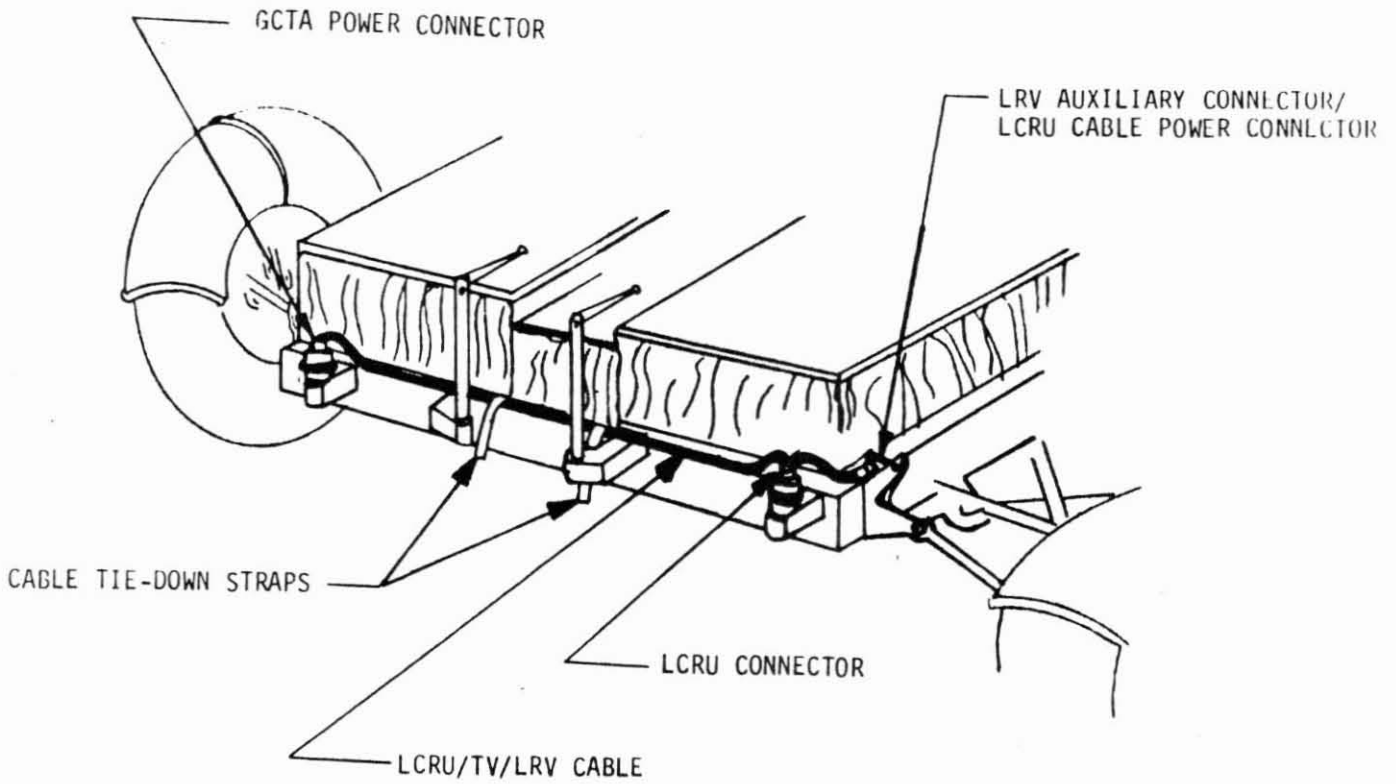

FIGURE 4-2. LCRU/TV/LRV CABLE STOWAGE

LS006-002-2H  
LUNAR ROVING VEHICLE  
OPERATIONS HANDBOOK

---

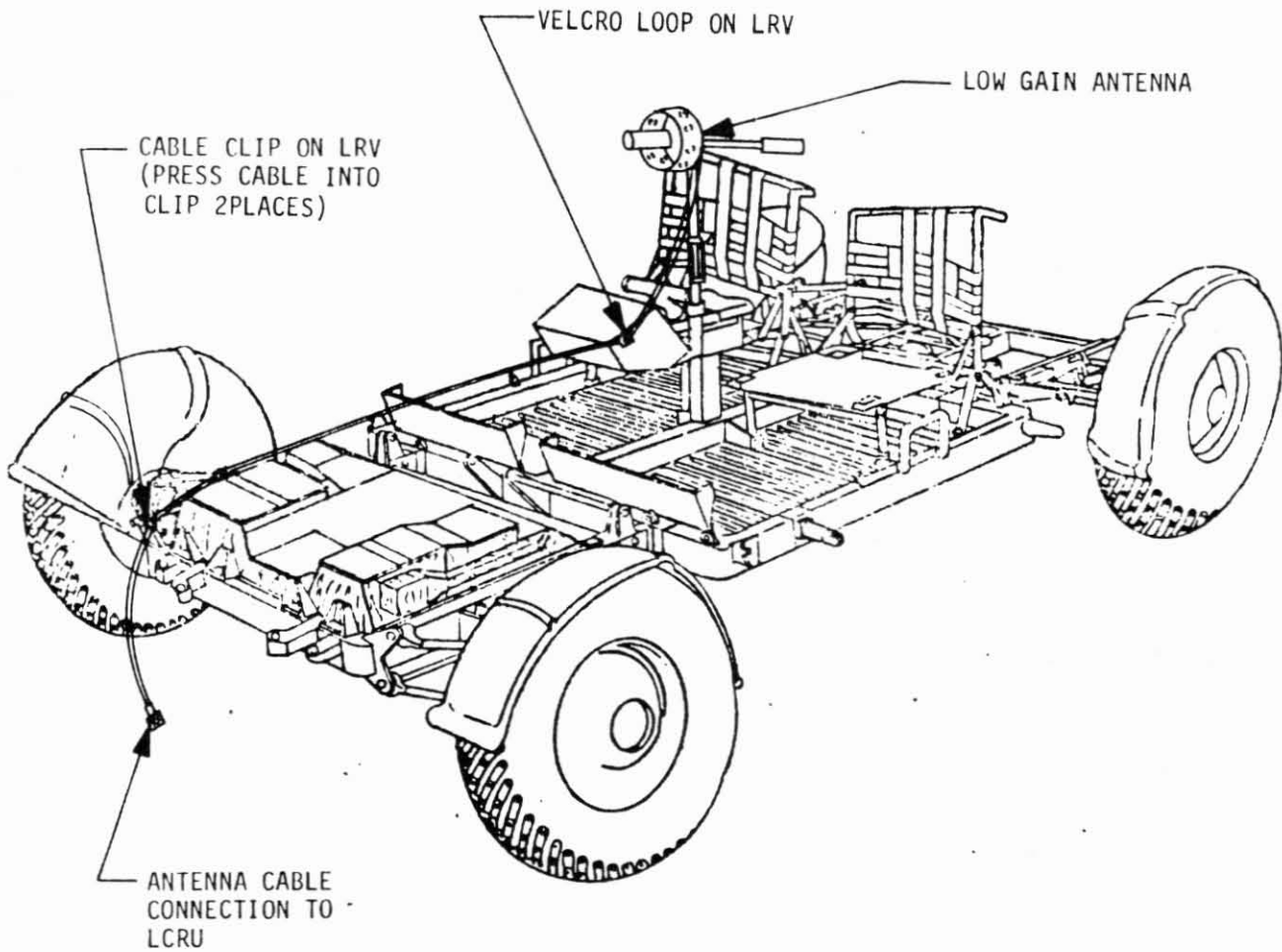

FIGURE 4-3 LCRU LOW GAIN ANTENNA CABLE  
INSTALLATION ON LUNAR SURFACE

LS006-002-2H  
LUNAR ROVING VEHICLE  
OPERATIONS HANDBOOK

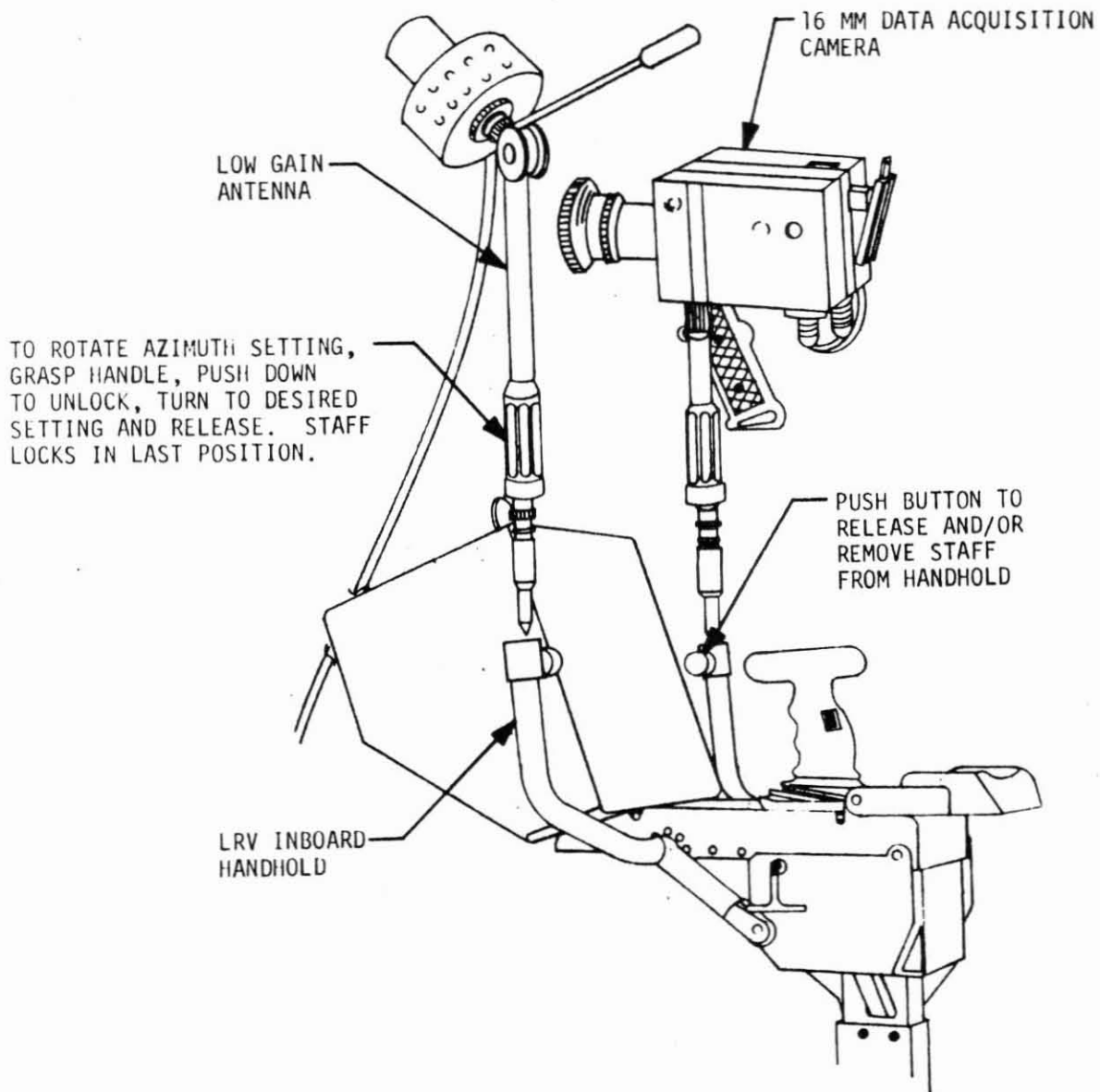

FIGURE 4-4 . 16 MM DAC AND LOW GAIN ANTENNA INSTALLATION

LS006-002-2H  
LUNAR ROVING VEHICLE  
OPERATIONS HANDBOOK

---

4.2.2 (Continued)

The two bags are identical and are of the configuration shown in figure 4-5. The forward end of each bag is secured to the seat support frame. The bags are automatically erected to the useable position when the seat support frames are raised during LRV activation. The aft ends of the bags are held in place by springs attached to the rear member of the center chassis and by attachment to cross member on the seat back.

During operations, access to the stowage bags is gained by raising the seat off the seat support which exposes the entire bag and contents.

4.2.3 Floor Payload Stowage

When only one astronaut is operating the LRV, the area normally used by the second crewman may be used for payload stowage. This is accomplished by placing the seat in the operational stowage position shown in figure 4-6. The seat is secured in the stowed position by velcro straps.

NOTE: The under seat stowage bag must be removed to use the floor area as a stowage area.

4.2.4 Back-of-Seat Payload Stowage

The Buddy SLSS umbilical is carried in a bag attached to the back of the LRV right seat. Specific interface is shown in figure 4-7.

4.3 REAR CHASSIS PAYLOAD PROVISIONS

Payload stowage provisions for the rear chassis are shown in figures 4-8 and 4-9. The LH and RH adapters and pallet support posts are installed on the LRV before launch, arriving on the lunar surface in the configuration shown in figure 4-8. The payload pallet which interfaces with the adapters and support posts is stowed in LM Quadrant III, and arrives on the lunar surface with payload items already installed on the pallet. The crew removes the pallet from Quadrant III and installs the pallet, with attached payload, onto the support post and adapters on the LRV.

\*\*\* IG Trainer Note \*\*\*

The rear chassis payload adapters for the IG Trainer will allow identical astronaut functions to be performed, but the configuration of the adapters is not exactly identical to the LRV adapters.



LS006-002-2H  
LUNAR ROVING VEHICLE  
OPERATIONS HANDBOOK

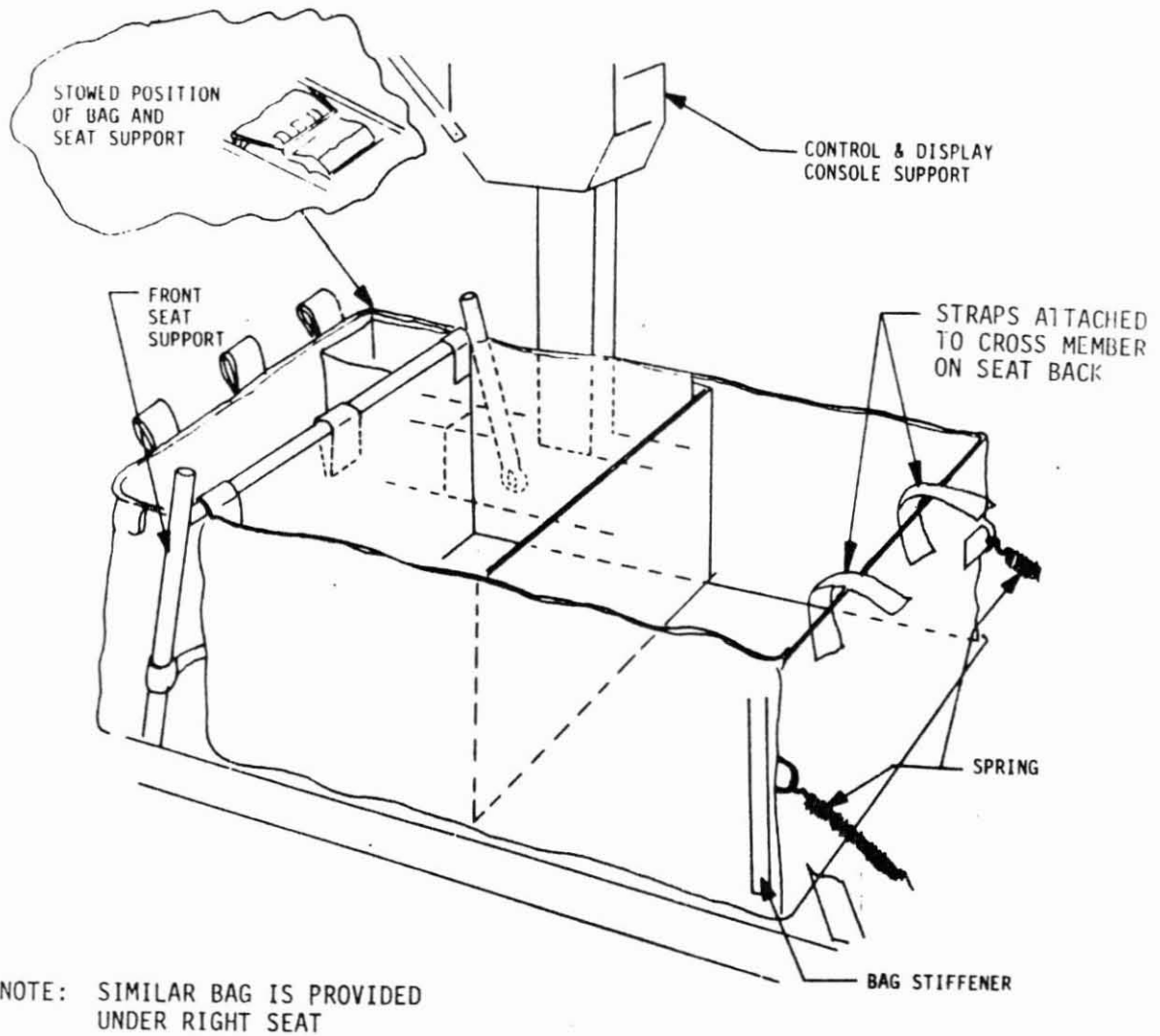

FIGURE 4-5 UNDER-SEAT STOWAGE BAG (LEFT SEAT)

LS006-002-2H  
 LUNAR ROVING VEHICLE  
 OPERATIONS HANDBOOK

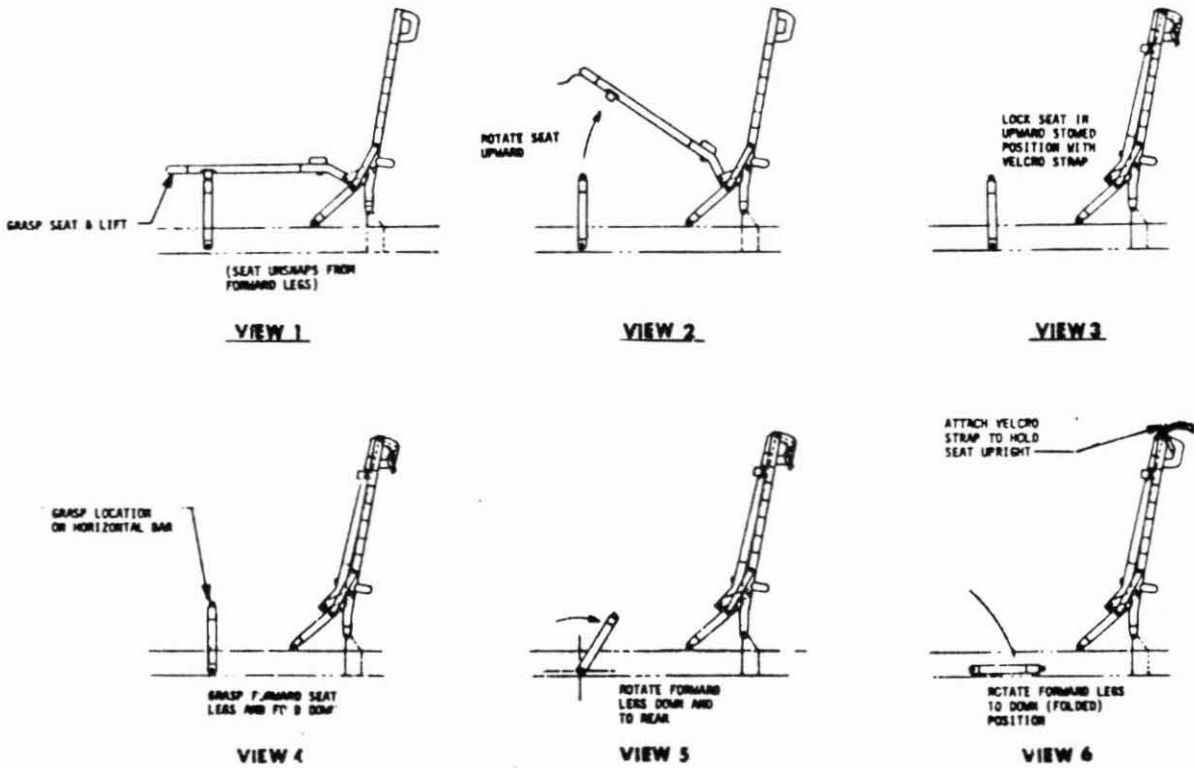

FIGURE 4-6 PASSENGER SEAT STOWAGE TO CREATE PAYLOAD AREA ON CENTER CHASSIS FLOOR

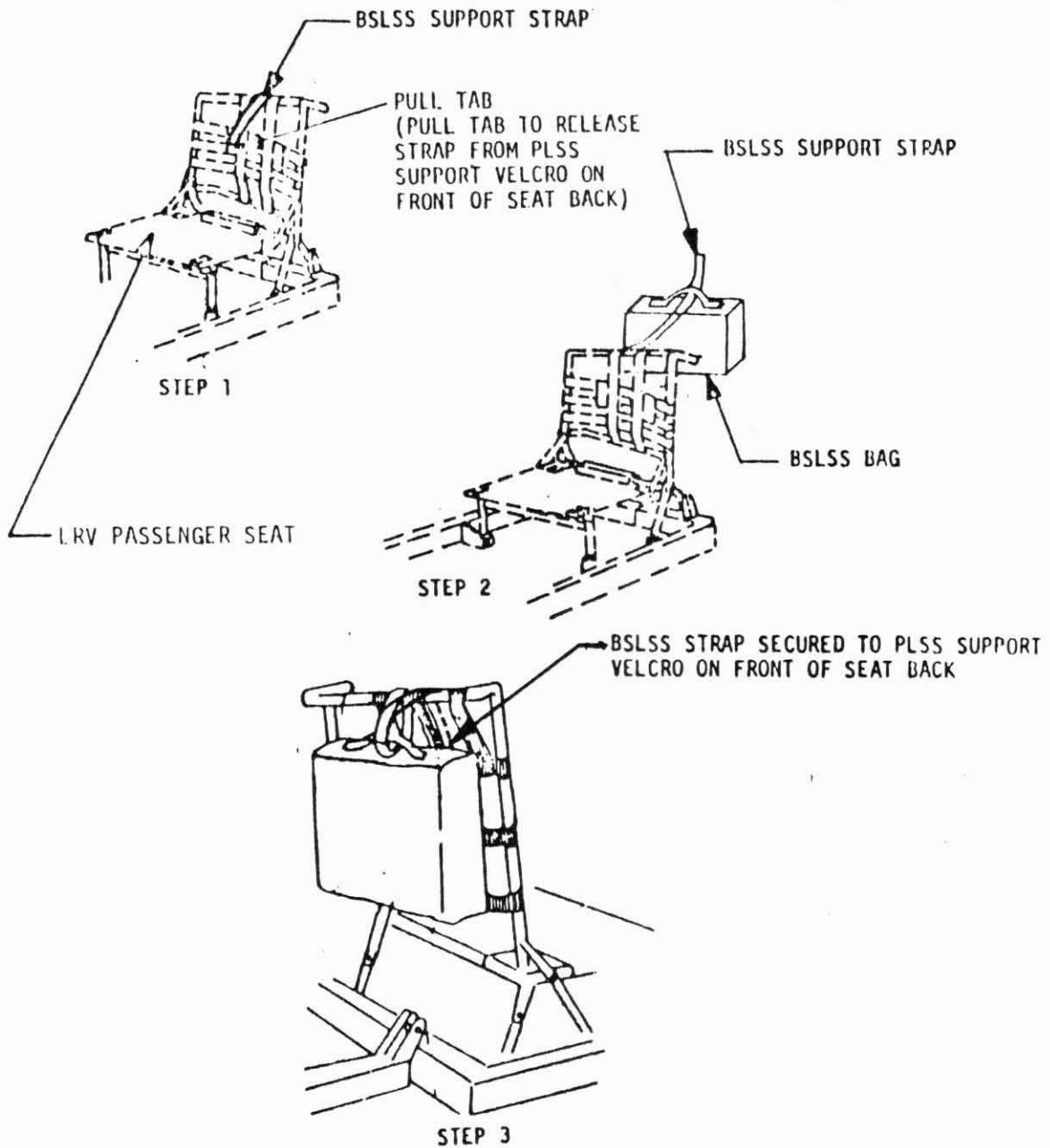

FIGURE 4-7. BUDDY SLSS INSTALLATION

LS006-002-2H  
LUNAR ROVING VEHICLE  
OPERATIONS HANDBOOK

---

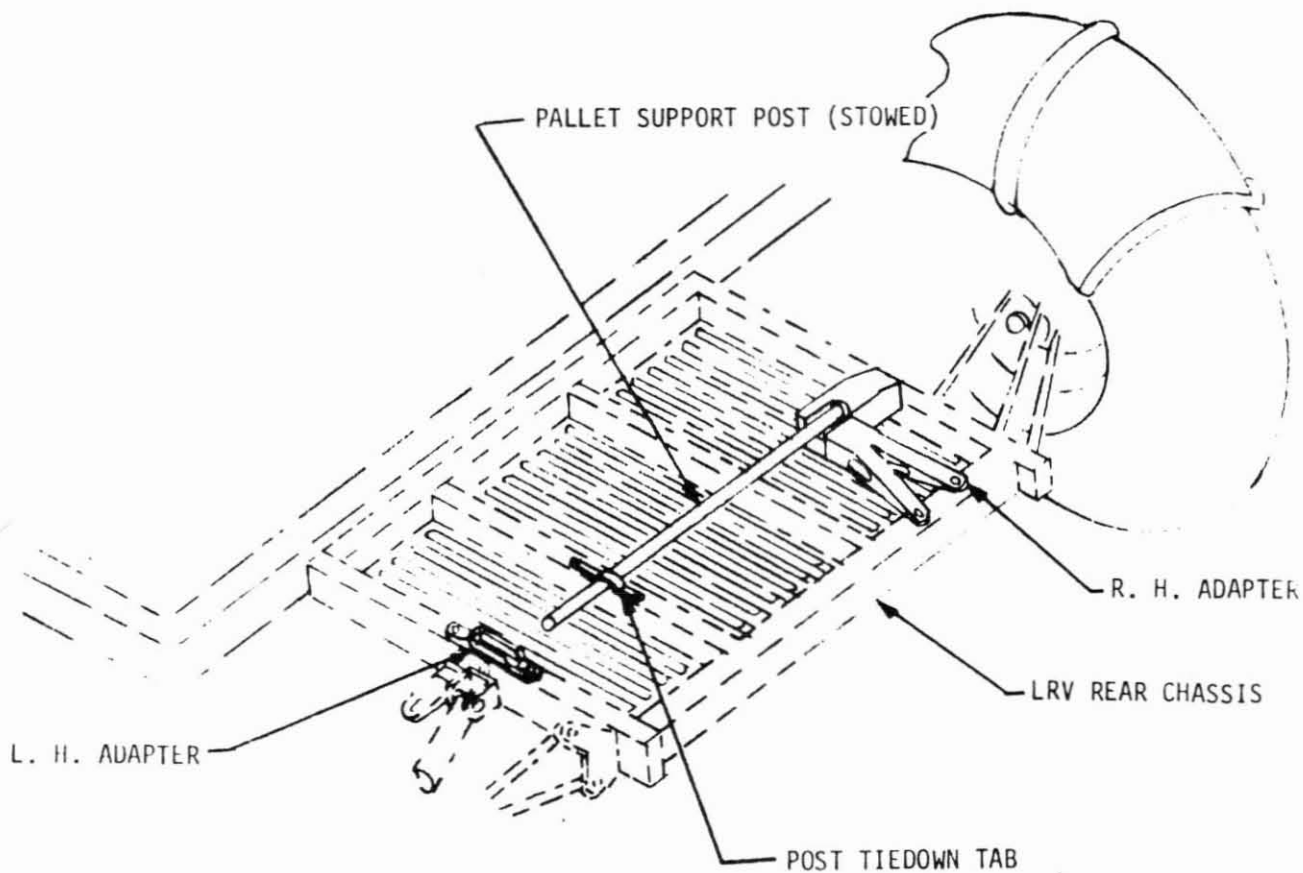

FIGURE 4-8 LRV REAR PAYLOAD PALLET ADAPTERS

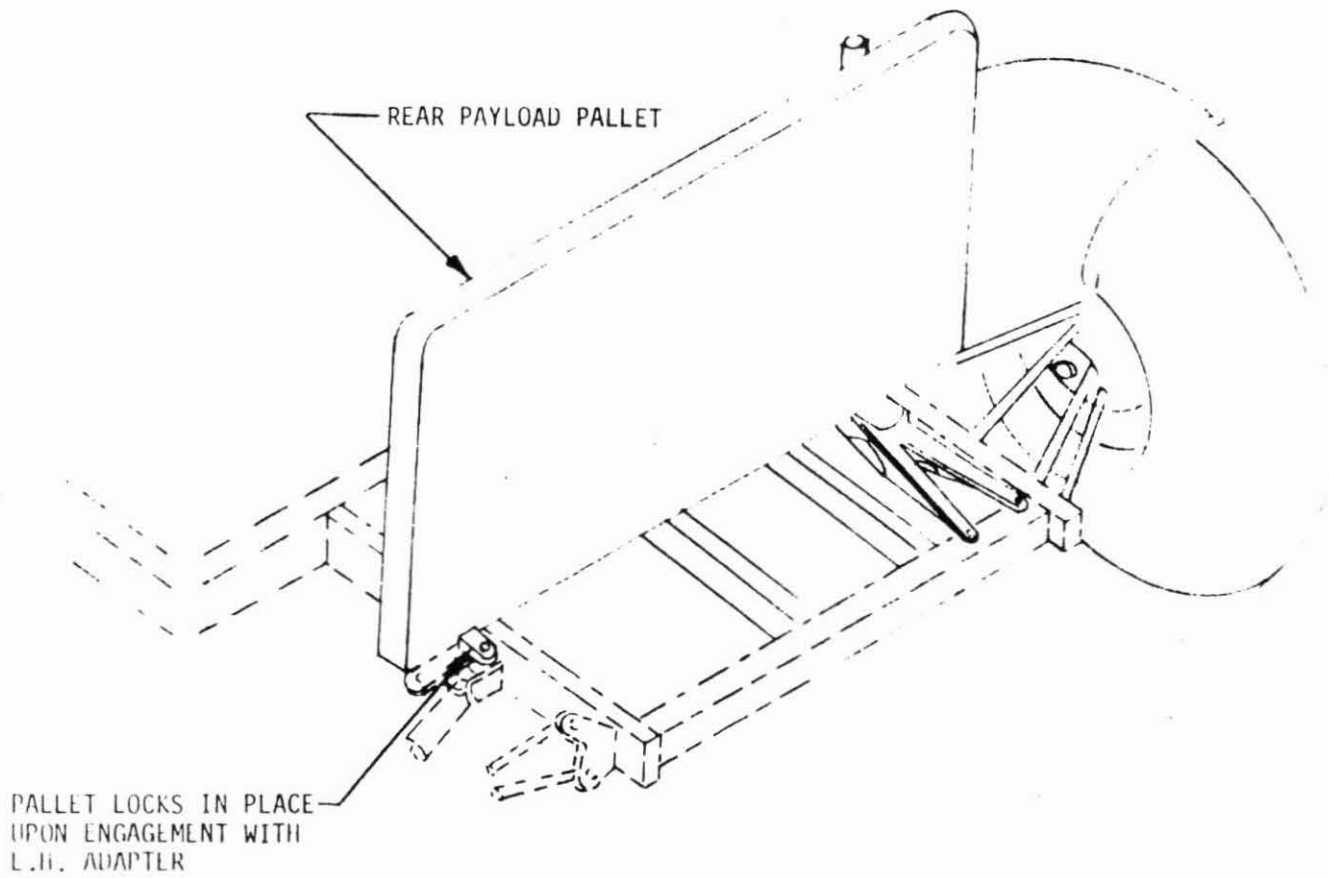

FIGURE 4-9 REAR PAYLOAD PALLET INSTALLED

SECTION 5  
OPERATING LIMITATIONS

5.0 INTRODUCTION

This section contains the LRV operating limitations.

5.1 PAYLOAD LIMITATIONS

The LRV is designed for lunar operation a total payload of 970 pounds earth weight distributed as defined by the LRV to Stowed Payload Interface Control Document, 13M07391. Loading the LRV beyond the 970 pound limit will cause the structural factor of safety to be lessened below the 1.5 design case.

The allowable center of gravity location for the total LRV, including payload, is shown in Figure 5-1. Loading the LRV such that the center of gravity falls outside the defined envelope will cause degradation of performance, including:

- a. Possible steering discontinuity
- b. Possible traction drive discontinuity
- c. Possible periods of instability

\*\*\*1G TRAINER NOTE\*\*\*

The 1G Trainer is designed for a gross payload of 800 pounds. Performance degradation will occur if overloaded.

5.2 PARKING LIMITATIONS

To achieve proper thermal control of the LRV and stowed payload during between-EVA parking periods, the LRV must be oriented per figure 5-2. Parking the LRV outside these limits will result in display and control component overheating or LCRU overheating. There are no orientation constraints imposed on short-term parking during EVA's.

\*\*\*1G TRAINER NOTE\*\*\*

There are no parking limitations for the 1G Trainer.

5.3 SORTIL LIMITATIONS

The LRV is designed for EVA's of 6 hours duration. The thermal design is based on 3 hours of mobility operation in the 6-hour EVA, with the navigation system and controls and displays remaining on during the entire 6-hour EVA. Operation of the vehicle beyond these time durations will cause thermal limits to be exceeded.

The LRV is designed for continuous operation in shadows for not more than 2 hours due to temperature limits on the Control and Display components. See Appendix A for temperature rise and cooldown times.

LS006-002-2H  
 LUNAR ROVING VEHICLE  
 OPERATIONS HANDBOOK

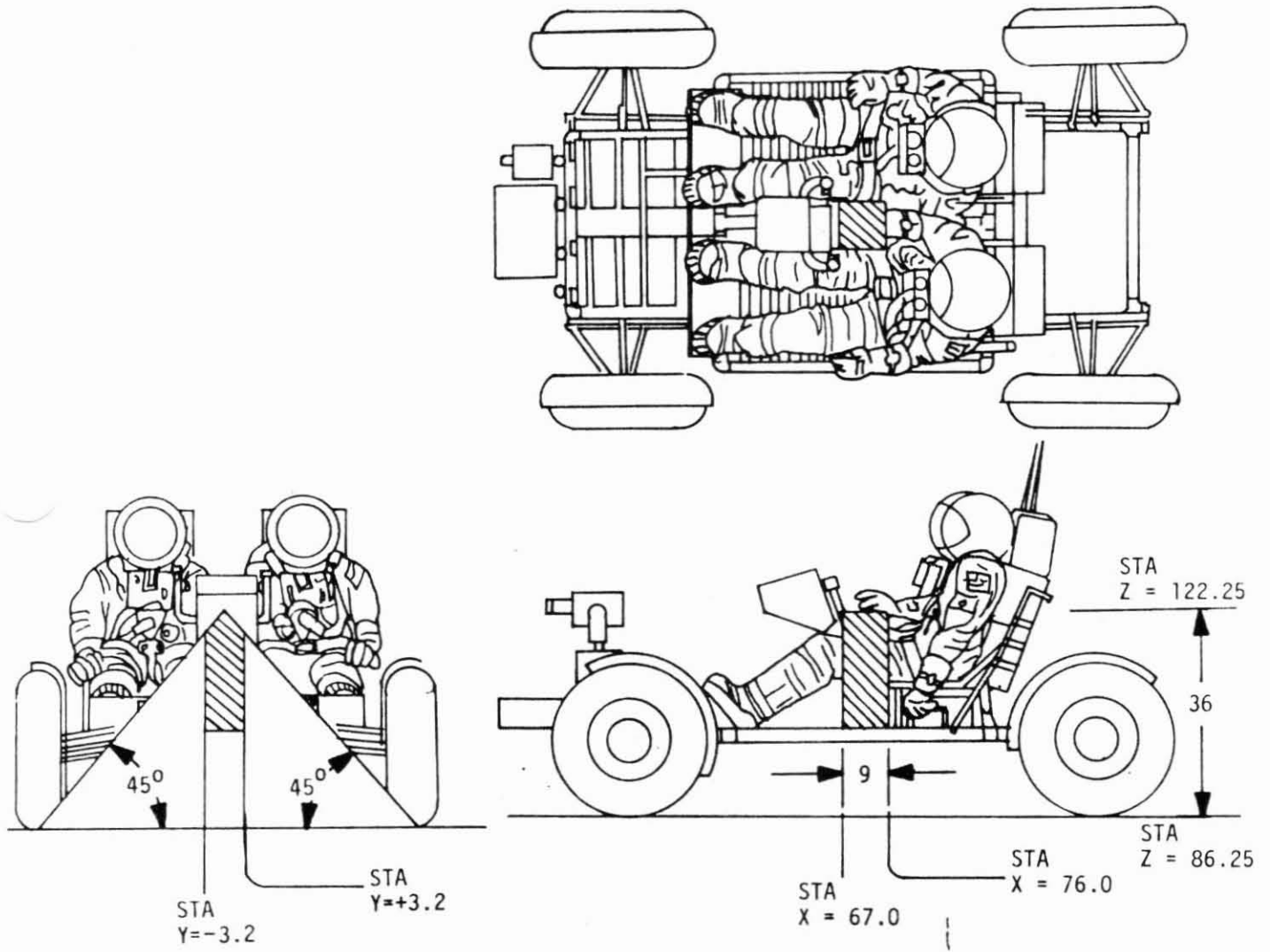

FIGURE 5-1. ALLOWABLE C.G. ENVELOPE FOR VEHICLE FULLY LOADED

LS006-002-2H  
LUNAR ROVING VEHICLE  
OPERATIONS HANDBOOK

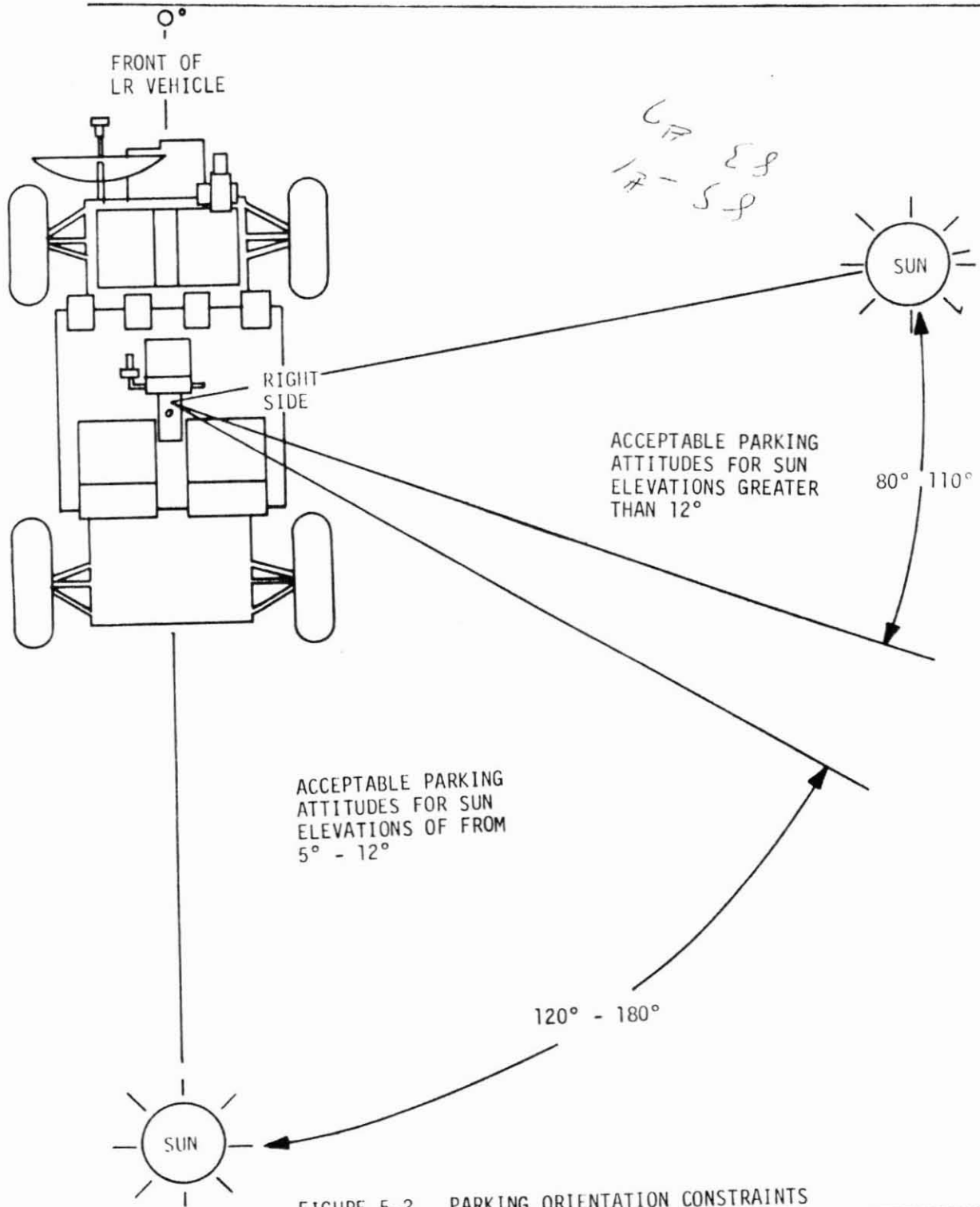

FIGURE 5-2. PARKING ORIENTATION CONSTRAINTS



LS006-002-2H  
LUNAR ROVING VEHICLE  
OPERATIONS HANDBOOK

---

5.4 NAVIGATION SYSTEM LIMITATIONS

The following limitations are placed on operating the LRV and 1G Trainer Navigation System.

- a. The Navigation System is to be on for a minimum of three minutes before initialization to allow the gyro to reach operating speed.
- b. The GYRO TORQUING Switch is not to be kept in the LEFT or RIGHT position for more than two minutes. After two minutes on, the switch must be kept OFF for a minimum of five minutes to prevent damage to the gyro torquing motor.
- c. The navigation input voltage must not be allowed to be less than 30 VDC to prevent excessive computation and display errors and to prevent damage to navigation equipment if the under-voltage situation is prolonged. Therefore, it is imperative that the NAV POWER circuit breaker be open if the VOLTS indicator indicates less than 60. The VOLTS indicator should be checked periodically (at least each 15 minutes) to verify readings of not less than 60.

SECTION 6  
OPERATING TIMELINES

6.0 INTRODUCTION

This section defines the approximate times for performing LRV functions on the lunar surface and 1G Trainer functions on earth.

\*\*\*1G TRAINER NOTE\*\*\*

Timelines for 1G Trainer operation are identical to those shown for LRV lunar surface operations except for traction drive decoupling and steering decoupling.

Included in this section are timelines for:

- Figure 6-1 - LRV Deployment
- 6-2 - Post-Deployment Checkout
- 6-3 - Pre-Sortie Checkout and Preparation
- 6-4 - Post-Sortie Shutdown
- 6-5 - Navigation Update
- 6-6 - Traction Drive Decoupling
- 6-7 - Steering Decoupling
- 6-8 - Rear Steering Recoupling
- 6-9 - 1G Trainer Battery Changeout
- 6-10 - 1G Trainer Traction Drive Decoupling
- 6-11 - 1G Trainer Steering Decoupling

LS006-002-2H  
LUNAR ROVING VEHICLE  
OPERATIONS HANDBOOK

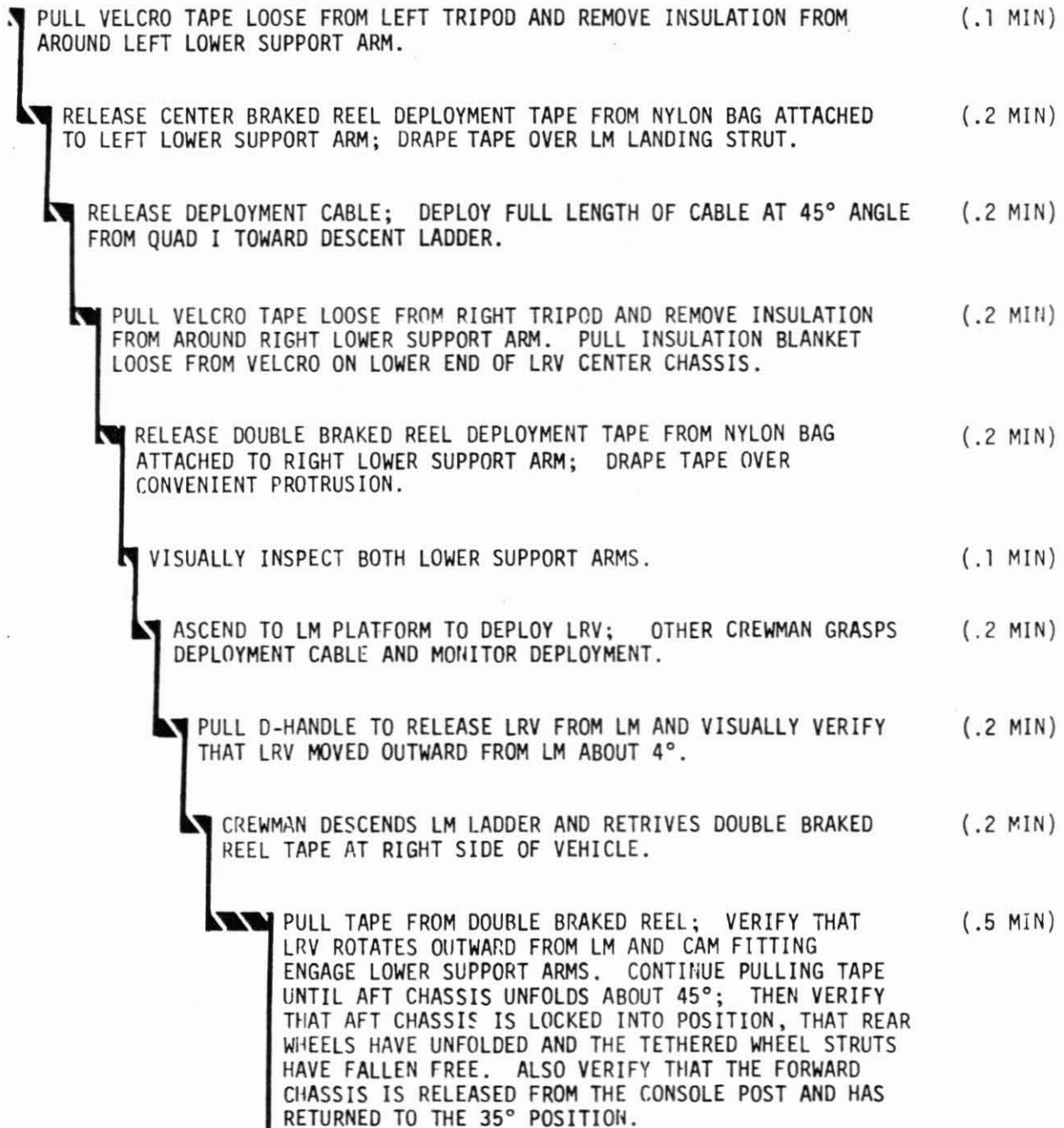

FIGURE 6-1 LRV DEPLOYMENT TIMELINE

LS006-002-2H  
LUNAR ROVING VEHICLE  
OPERATIONS HANDBOOK

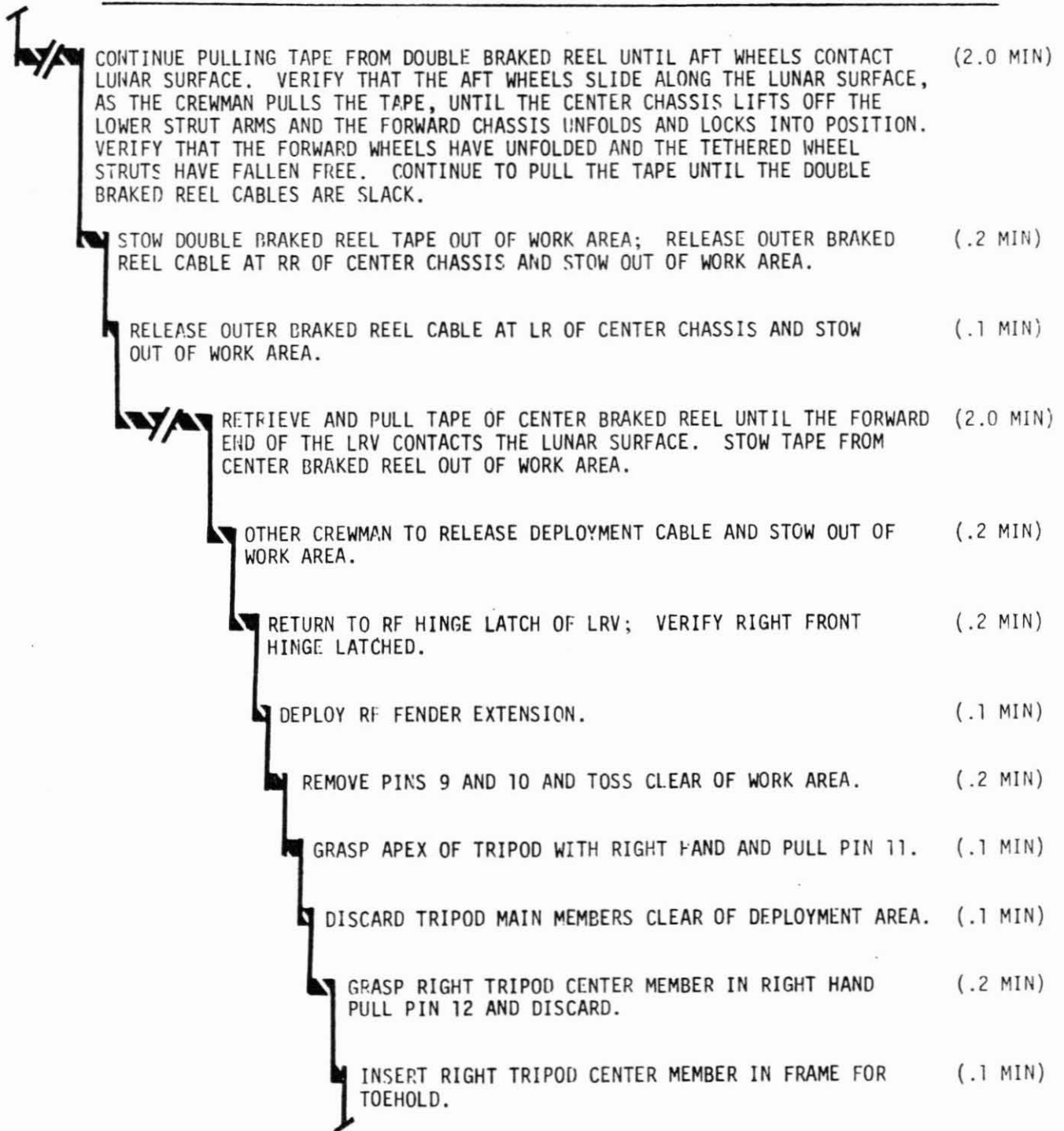

FIGURE 6-1 LRV DEPLOYMENT TIMELINE (CONTINUED)

LS006-002-2H  
LUNAR ROVING VEHICLE  
OPERATIONS HANDBOOK

|  |          |
|--|----------|
| RELEASE RIGHT FOOTREST RESTRAINT AND ERECT RIGHT FOOTREST AND VERIFY LATCHED IN POSITION.  | (.1 MIN) |
| PULL AND TURN C/D CONSOLE LATCH P13, 90° CW. WHEN CONSOLE DEPLOYS, RAISE INBOARD HANDHOLDS AND LOCK IN OPERATIONAL POSITION, ROTATE P13 90° CW AND VERIFY CONSOLE LOCKED IN POSITION | (.1 MIN) |
| RELEASE RIGHT SEAT BELT FROM STOWAGE POSITION AND STOW IN TEMPORARY LOCATION.  | (.1 MIN) |
| GRASP FRONT OF RIGHT SEAT FRAME AND LIFT TO STABLE OVERCENTER POSITION AND ERECT RIGHT SEAT FRONT LEGS. VERIFY SEAT STOWAGE BAG ERECTS.  | (.1 MIN) |
| PULL SEAT PAN FRAME UP AND POSITION ENDS OF FRAME UNDER BACK REST SUPPORT MEMBER LOWER SEAT FRAME TO ENGAGE FRONT LEGS AND VERIFY LATCHED.   | (.1 MIN) |
| VERIFY RIGHT REAR HINGE LATCHED.   | (.1 MIN) |
| VISUALLY VERIFY REAR STEERING DECOUPLING RING SEAL HAS NOT BEEN BROKEN.  | (.1 MIN) |
| DEPLOY RIGHT REAR FENDER EXTENSION.  | (.1 MIN) |
| VERIFY LEFT REAR HINGE LATCHED AND DEPLOY LEFT REAR FENDER EXTENSION.  | (.2 MIN) |
| RELEASE INBOARD HANDHOLD VELCRO TIEDOWN STRAP.   | (.1 MIN) |
| RELEASE LEFT SEAT BELT FROM STOWAGE POSITION AND STOW IN TEMPORARY LOCATION.   | (.1 MIN) |
| GRASP FRONT OF LEFT SEAT FRAME AND LIFT TO STABLE OVERCENTER POSITION AND ERECT LEFT SEAT FRONT LEGS. VERIFY SEAT STOWAGE BAG ERECTS.  | (.1 MIN) |

FIGURE 6-1 LRV DEPLOYMENT TIMELINE (CONTINUED)

LS006-002-2H  
LUNAR ROVING VEHICLE  
OPERATIONS HANDBOOK

|   |   |          |
|---|---|----------|
| 1 | PULL SEAT PAN FRAME UP AND POSITION ENDS OF FRAME UNDER BACK REST SUPPORT MEMBER. LOWER SEAT FRAME TO ENGAGE FRONT LEGS AND VERIFY LATCHED. | (.1 MIN) |
|   | FOLD INBOARD ARMREST DOWN.  | (.1 MIN) |
|   | SUPPORT CONSOLE WITH LEFT HAND; GRASP C/D CONSOLE PANEL "T" HANDLE P7, TURN 90° CW TO LOCKED POSITION.                                      | (.1 MIN) |
|   | ROTATE INBOARD HANDHOLD TO LOCKED POSITION WHILE ROTATING CONSOLE DOWNWARD WITH LEFT HAND.  | (.1 MIN) |
|   | ROTATE T-HANDLE P7 90° CW AND FOLD FLUSH WITH CONSOLE BOX AND SECURE INTO POSITION WITH VELCRO STRAP.                                       | (.1 MIN) |
|   | REMOVE ATTITUDE INDICATOR LOCK PIN AND DISCARD.   | (.1 MIN) |
|   | REMOVE C&W FLAG LOCK PIN AND DISCARD.   | (.1 MIN) |
|   | PULL PINS P3 AND 4 AND TOSS CLEAR OF WORK AREA.   | (.1 MIN) |
|   | GRASP TRIPOD APEX WITH LEFT HAND AND PULL PIN P5; DISCARD PIN P5 AND TRIPOD MAIN MEMBERS.   | (.1 MIN) |
|   | GRASP TRIPOD CENTER MEMBER IN LEFT HAND; PULL PIN P6 AND DISCARD.   | (.2 MIN) |
|   | USE HOOKED END OF SHORT TRIPOD MEMBER TO PULL CABLE P2 AND VERIFY THAT TELESCOPING RODS SADDLE FALLS AWAY.                                  | (.1 MIN) |
|   | INSERT TRIPOD CENTER MEMBER IN LRV FRAME FOR TOEHOLD.   | (.1 MIN) |
|   | RELEASE LEFT FOOTREST RESTRAINT DEVICE AND ERECT LEFT FOOTREST AND VERIFY LATCHED POSITION.   | (.1 MIN) |

FIGURE 6-1 LRV DEPLOYMENT TIMELINE (CONTINUED)

LS006-002-2H  
LUNAR ROVING VEHICLE  
OPERATIONS HANDBOOK

---

|   |  |          |
|---|--|----------|
| 1 | MOVE TO LEFT FRONT HINGE AREA AND VERIFY LEFT FRONT HINGE LATCHED.   | (.1 MIN) |
|   | DEPLOY LEFT FRONT FENDER EXTENSION.  | (.1 MIN) |
|   | INSPECT AND VERIFY BATTERY NO. 1 AND SPU DUST COVERS ARE CLOSED AND SECURED.                                 | (.1 MIN) |
|   | VERIFY THAT THE FORWARD STEERING DECOUPLING RING SEAL HAS NOT BEEN BROKEN.                                   | (.1 MIN) |
|   | MOVE TO RIGHT SIDE OF VEHICLE AND VERIFY THAT BATTERY NO. 2 DUST COVER IS CLOSED AND SECURED.                | (.2 MIN) |
|   | AT RIGHT SIDE OF VEHICLE ROTATE "T" HANDLE P13 90° CW AND FOLD "T" HANDLE FLUSH WITH CONSOLE BOX AND SECURE. | (.2 MIN) |

LPV DEPLOYMENT COMPLETE.

TOTAL TIME 11.0 MINUTES

FIGURE 6-1. LRV DEPLOYMENT TIMELINE (CONTINUED)

LS006-002-211  
LUNAR ROVING VEHICLE  
OPERATIONS HANDBOOK

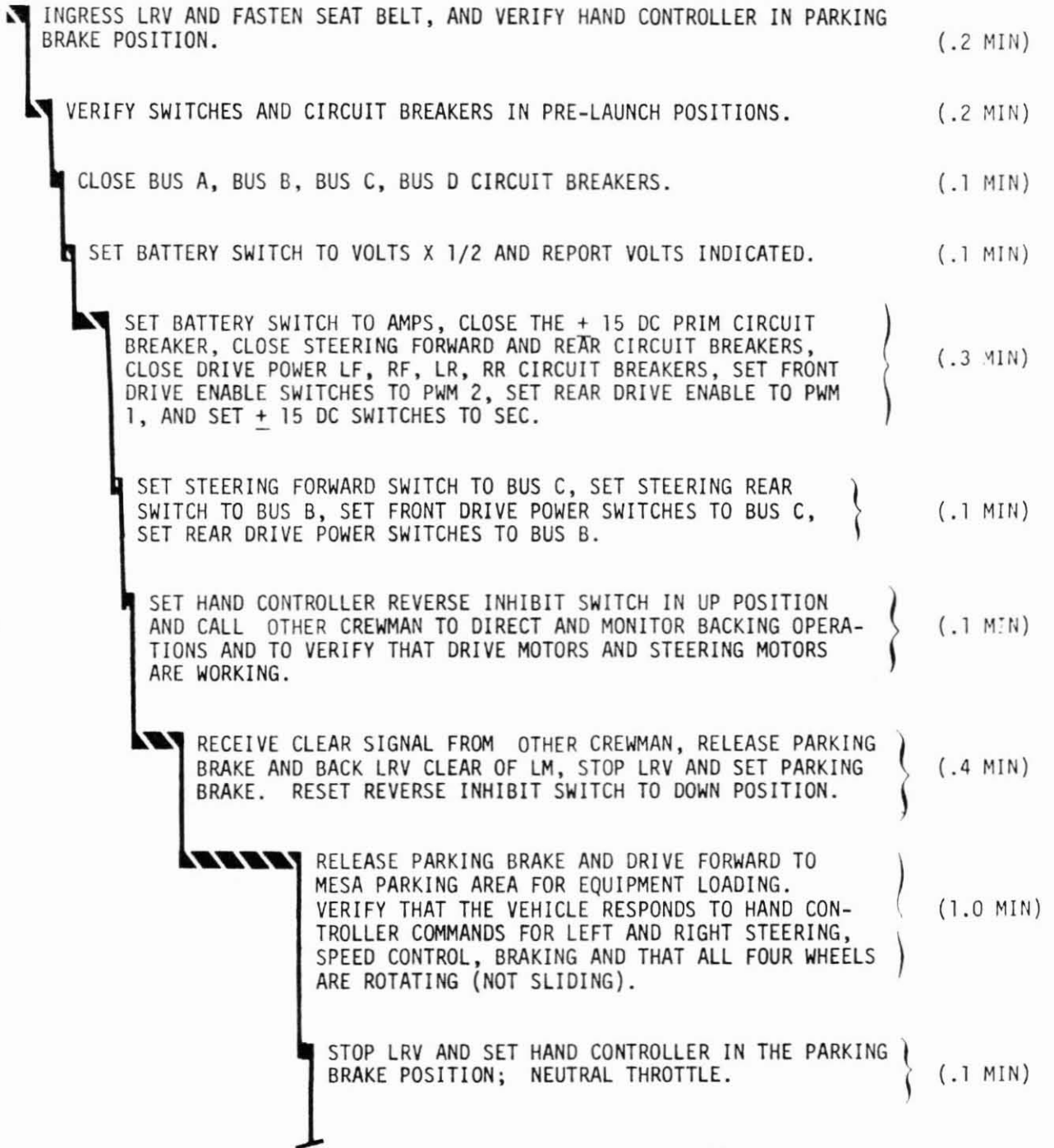

FIGURE 6-2. LRV POST DEPLOYMENT CHECKOUT TIMELINE



LS006-002-2H  
LUNAR ROVING VEHICLE  
OPERATIONS HANDBOOK

SHUT DOWN LRV POWER AND VERIFY THAT THE HAND CONTROLLER IS IN THE PARKING BRAKE POSITION, THAT THE FRONT AND REAR DRIVE POWER SWITCHES ARE OFF, THAT THE FORWARD AND REAR STEERING SWITCHES ARE OFF, THAT THE  $\pm$  15 VDC SWITCH IS OFF AND THAT THE NAV POWER CIRCUIT BREAKER IS OPEN. } (.2 MIN)

RELEASE AND STOW SEAT BELT; EGRESS VEHICLE. (.3 MIN)

(TOTAL TIME 3.1 MIN.)

FIGURE 6-2. LRV POST DEPLOYMENT CHECKOUT TIMELINE  
(CONTINUED)

LS006-002-2H  
LUNAR ROVING VEHICLE  
OPERATIONS HANDBOOK

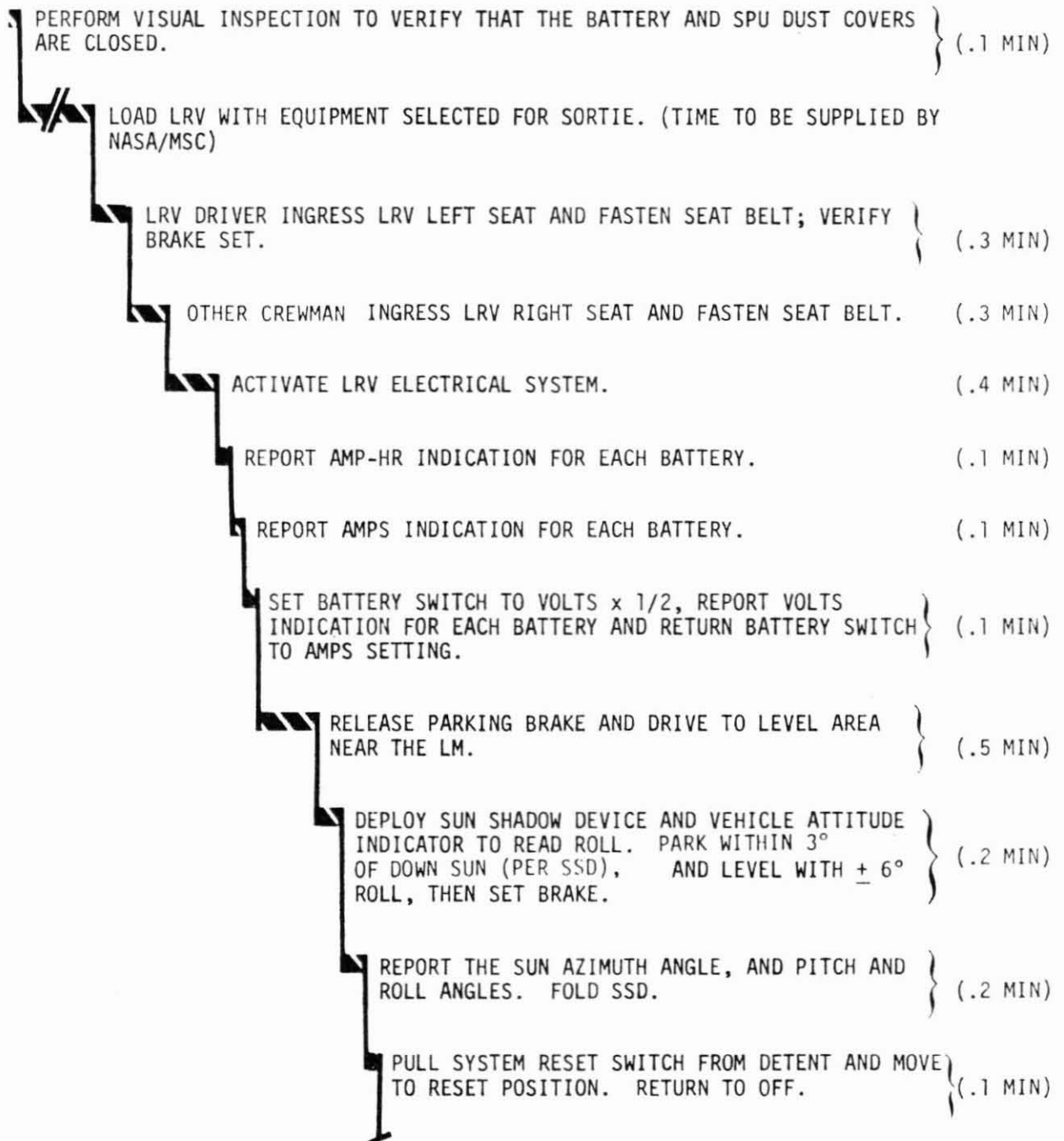
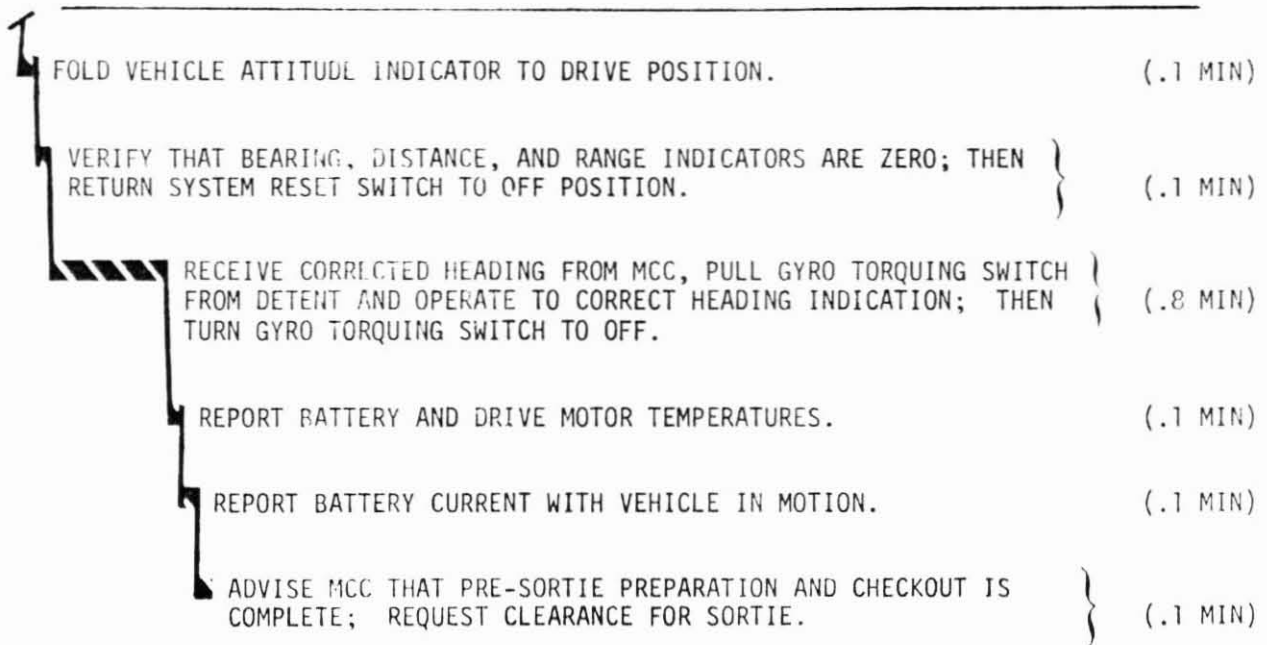

FIGURE 6-3. PRE-SORTIE CHECKOUT AND PREPARATION TIMELINE

LS006-002-2H  
LUNAR ROVING VEHICLE  
OPERATIONS HANDBOOK



(TOTAL TIME 3.7 MIN. PLUS  
EQUIPMENT LOADING TIME)

FIGURE 6-3. PRE-SORTIE CHECKOUT AND PREPARATION TIMELINE  
(CONTINUED)

LS006-002-2H  
LUNAR ROVING VEHICLE  
OPERATIONS HANDBOOK

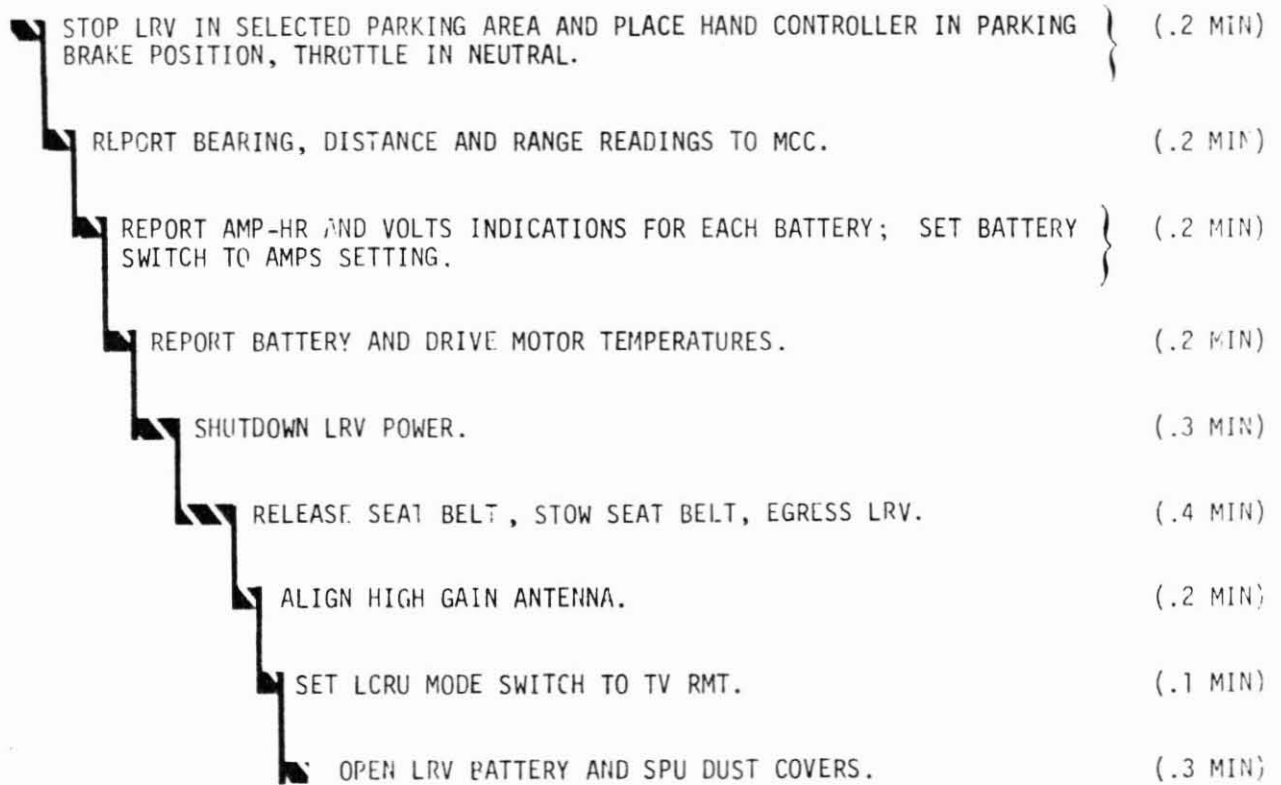

TOTAL TIME 2.1 MIN

FIGURE 6-4. POST-SORTIE SHUTDOWN  
TIMELINE

LS006-002-2H  
LUNAR ROVING VEHICLE  
OPERATIONS HANDBOOK

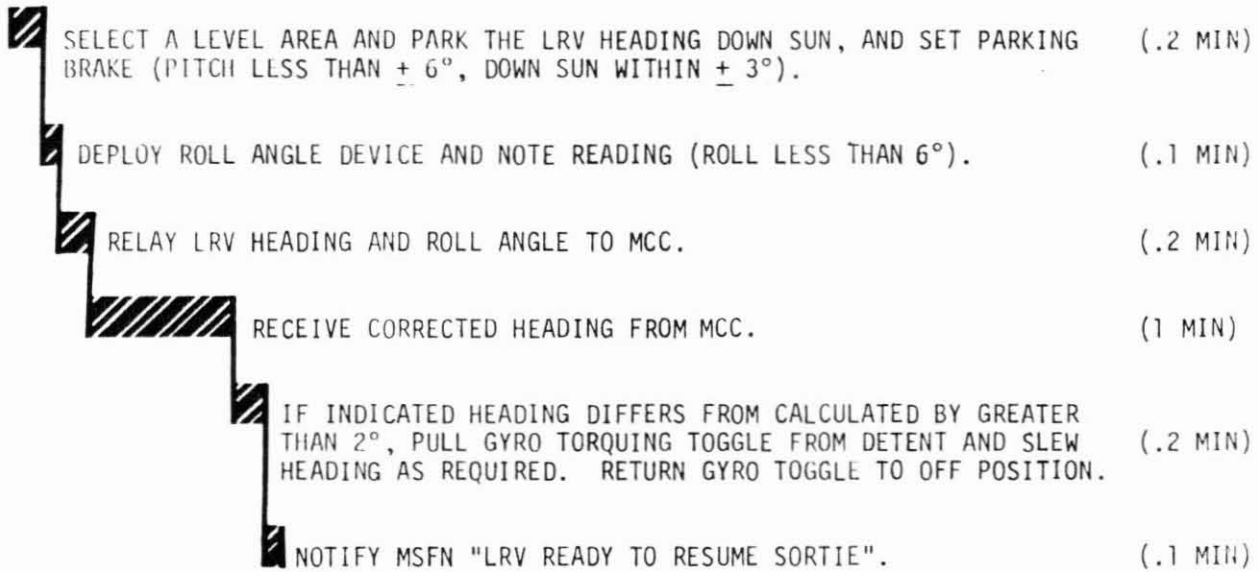

TOTAL TIME 1.8 MIN

FIGURE 6-5. NAVIGATION UPDATE TIMELINE

LS006-002-2H  
LUNAR ROVING VEHICLE  
OPERATIONS HANDBOOK

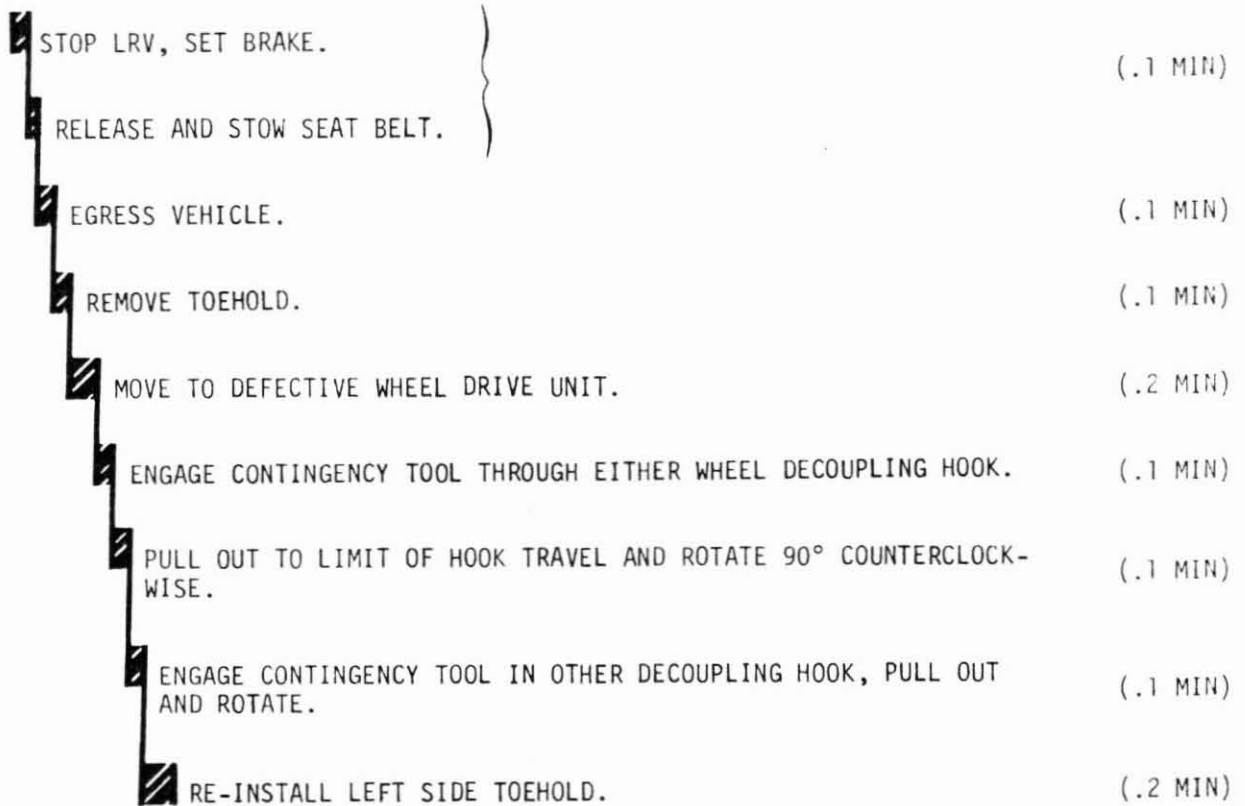

\*\*\*1G TRAINER NOTE\*\*\*

TIMES ARE IDENTICAL FOR 1G TRAINER  
SIMULATED DECOUPLING. (SEE FIGURE  
6-9 FOR ACTUAL TIME REQUIRED FOR  
TECHNICIAN TO EFFECT DECOUPLING)

TOTAL TIME (1.0 MIN)

FIGURE 6-6. LRV TRACTION DRIVE DECOUPLING TIMELINE  
(CONTINGENCY OPERATION)

LS006-002-2H  
LUNAR ROVING VEHICLE  
OPERATIONS HANDBOOK

---

|   |          |
|---|----------|
| STOP LRV AND SET BRAKE. TURN DRIVE POWER AND STEERING OFF   | (.2 MIN) |
| RELEASE AND STOW SEAT BELT.   | (.1 MIN) |
| EGRESS VEHICLE.   | (.2 MIN) |
| MOVE TO LEFT FRONT OR RIGHT REAR DECOUPLING RING LOCATION AS APPROPRIATE.                               | (.2 MIN) |
| PULL STEERING DECOUPLING RING AS APPROPRIATE.   | (.1 MIN) |
| MANUALLY STRAIGHTEN WHEELS OF DEFECTIVE DRIVE SYSTEM. MOVEMENT OF WHEEL MAY BE NECESSARY FOR DECOUPLING | (.3 MIN) |

\*\*\*1G TRAINER NOTE\*\*\*

TIMES ARE IDENTICAL FOR 1G TRAINER  
SIMULATED DECOUPLING. (SEE FIGURE  
6-10 FOR ACTUAL TIME REQUIRED FOR  
TECHNICIAN TO EFFECT DECOUPLING)

TOTAL TIME 1.1 MIN

FIGURE 6-7. LRV STEERING DECOUPLING TIMELINE  
(CONTINGENCY OPERATION)

LS006-002-2H  
LUNAR ROVING VEHICLE  
OPERATIONS HANDBOOK

---

|  |          |
|--|----------|
| STOP LRV AND SET BRAKE. TURN DRIVE POWER AND STEERING OFF  | (.2 MIN) |
| RELEASE AND STOW SEAT BELT   | (.1 MIN) |
| EGRESS VEHICLE   | (.2 MIN) |
| MOVE TO AREA FRONT OF RIGHT REAR FENDER  | (.2 MIN) |
| RELEASE RECOUPLING TOOL TIEDOWN VELCRO STRAP AND REMOVE RECOUPLING TOOL FROM STOWAGE BLOCK   | (.1 MIN) |
| PULL TAB TO OPEN REAR STEERING SECTOR DUST COVER AND PULL DUST COVER BACK  | (.1 MIN) |
| PUSH BUTTON ON TOP OF SECTOR GEAR TO RE-ENGAGE GEAR  | (.1 MIN) |
| INSERT RECOUPLING TOOL IN TOP OF RAISED AREA ON SECTOR GEAR, ROTATE TOOL TO ENGAGE LOCK PIN AND LIFT TOOL UNTIL PIN LOCKS IN RAISED POSITION. REMOVE TOOL. | (.2 MIN) |
| REPLACE STEERING SECTOR DUST COVER   | (.1 MIN) |
| REPLACE RECOUPLING TOOL IN STOWAGE BLOCK AND SECURE WITH VELCRO STRAP.   | (.1 MIN) |

\*\*\*1G Trainer Note\*\*\*

RECOUPLING OF THE REAR STEERING FOR THE 1G TRAINER WILL BE PERFORMED BY A TECHNICIAN.

TOTAL TIME 1.4 MINUTES

FIGURE 6-8. LRV REAR STEERING RECOUPLING TIMELINE (CONTINGENCY OPERATION)



LS006-002-2H  
LUNAR ROVING VEHICLE  
OPERATIONS HANDBOOK

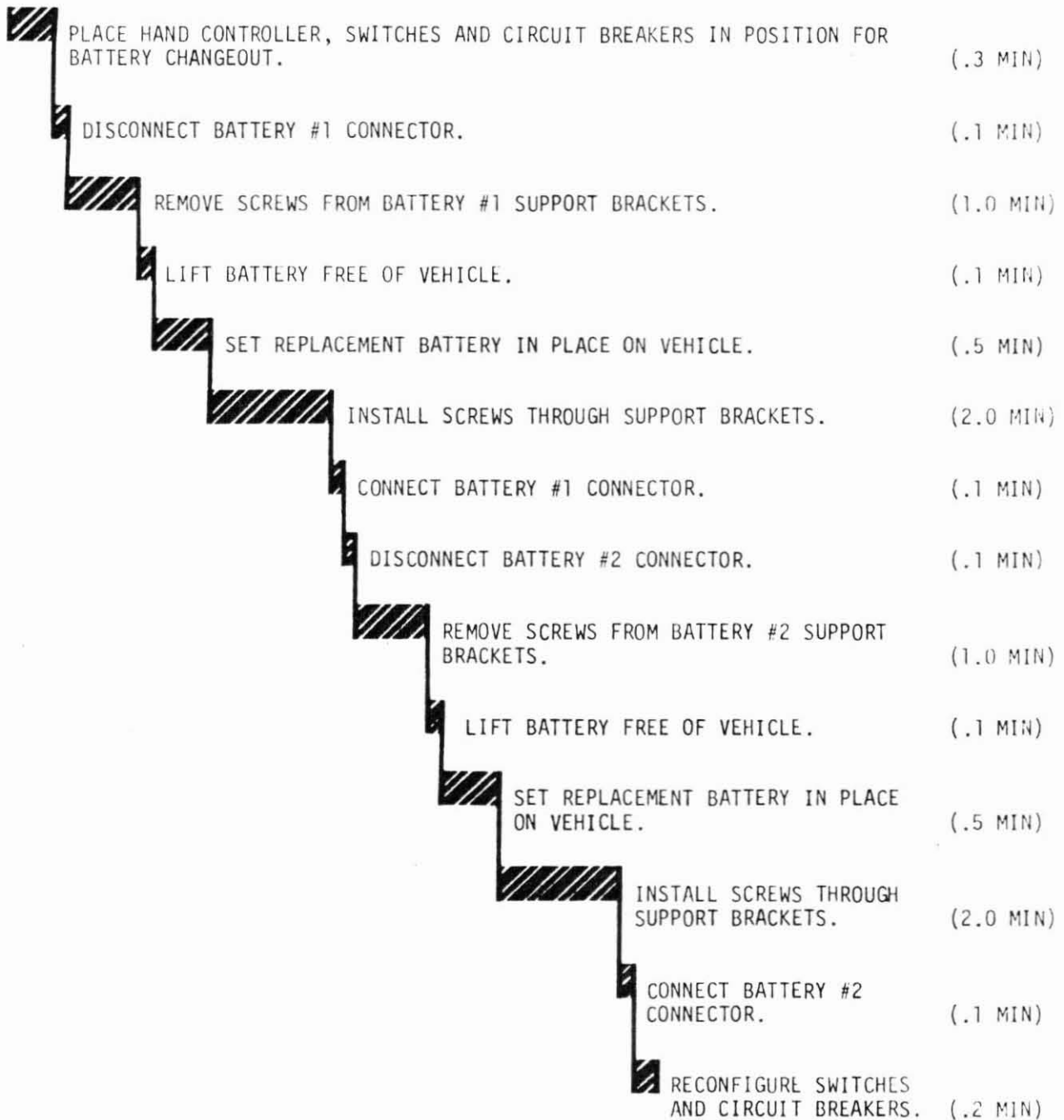

TOTAL TIME 8.1 MIN

FIGURE 6-9. 1G TRAINER BATTERY CHANGEOUT

LS006-002-2H  
LUNAR ROVING VEHICLE  
OPERATIONS HANDBOOK

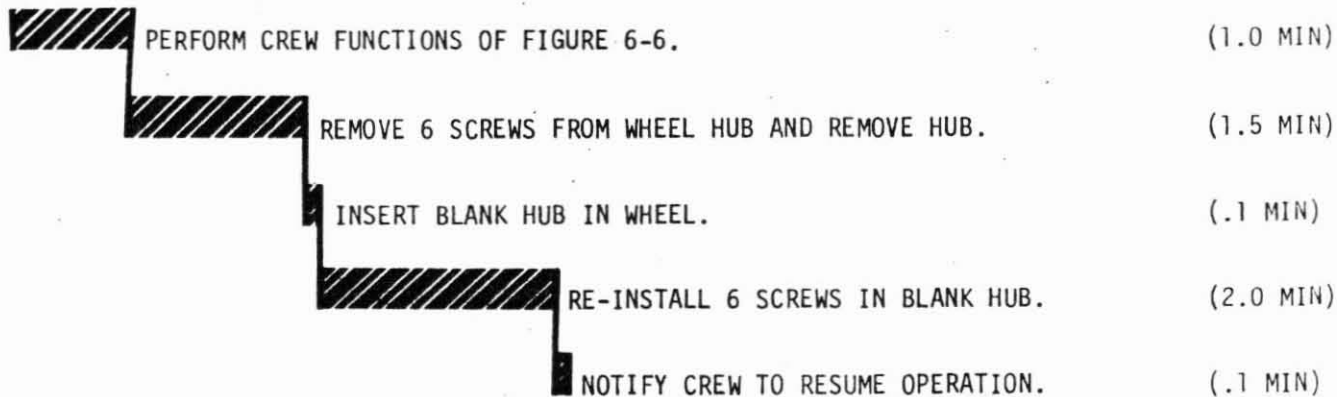





TOTAL TIME 4.7 MIN

FIGURE 6-10. 1G TRAINER TRACTION DRIVE DECOUPLING TIMELINE

LS006-002-2H  
LUNAR ROVING VEHICLE  
OPERATIONS HANDBOOK

---

|   |  |           |
|---|--|-----------|
|   | PERFORM CREW FUNCTIONS OF FIGURE 6-7.                              | (.8 MIN)  |
|  | INSTALL CLAMP ON LEFT STEERING ARM, BUTTED AGAINST CHASSIS FRAME.  | (1.0 MIN) |
|  | INSTALL CLAMP ON RIGHT STEERING ARM, BUTTED AGAINST CHASSIS FRAME. | (1.0 MIN) |
|  | NOTIFY CREW TO RESUME OPERATION.                                   | (.1 MIN)  |

TOTAL TIME 2.9 MIN

FIGURE 6-11. 1G TRAINER STEERING DECOUPLING TIMELINE

LS006-002-2H  
LUNAR ROVING VEHICLE  
OPERATIONS HANDBOOK

---

SECTION 7  
OPERATING PROFILES

7.1 LRV OPERATING PROFILE

7.1.1 Normal Operating Profile

The LRV is designed for nominal operation in accordance with the profile shown in figure 7-1 for a lunar surface stay time of 78 hours.

7.1.1.1 Sortie Profile

- o The normal sortie profile consists of a maximum of 3 hours of driving time and 3 hours of station time, to total 6 hours per LRV sortie.
- o The normal sortie will be accomplished with all four traction drives and both steering assemblies active.
- o During the sortie, stops will be made at periodic intervals to update LRV navigation system. At these stops, the crew will report indicator readouts per 2.6.

NOTE

Navigation updates will be performed only if indicator HEADING differs from MCC Calculated heading by more than 2°.

- o The LRV navigation system and console displays will remain energized throughout the six hour sortie duration.
- o At stops exceeding five minutes, the power to the traction drive units, steering motors, and drive controller will be turned off (accomplished by placing STEERING FRONT and REAR switches OFF; LF, RF, LR, RR DRIVE POWER switches OFF, and  $\pm$  15VDC switch OFF).
- o Circuit breakers and switch settings will be set to utilize both batteries at approximately the same rate, (e.g., steering for the front wheels powered from Battery No. 1 and steering for the rear wheels from Battery No. 2).
- o Power from the auxiliary connector will be supplied only as required by the LCRU for special cases.
- o Driving speed during the sortie will be varied at the crew's discretion. The speed profile for a sortie leg would consist of beginning at zero, accelerating to a desired driving speed, repeating cycles of decelerating to a slower speed, re-accelerating to the desired driving speed, and decelerating to stops. Speed will vary between zero and 14 km/hr.
- o Operation of the LCRU high gain antenna and the television camera will be conducted only when the LRV is stopped. The low gain antenna will be manually oriented during LRV traverses.

FIGURE 7-1 NOMINAL OPERATING PROFILE

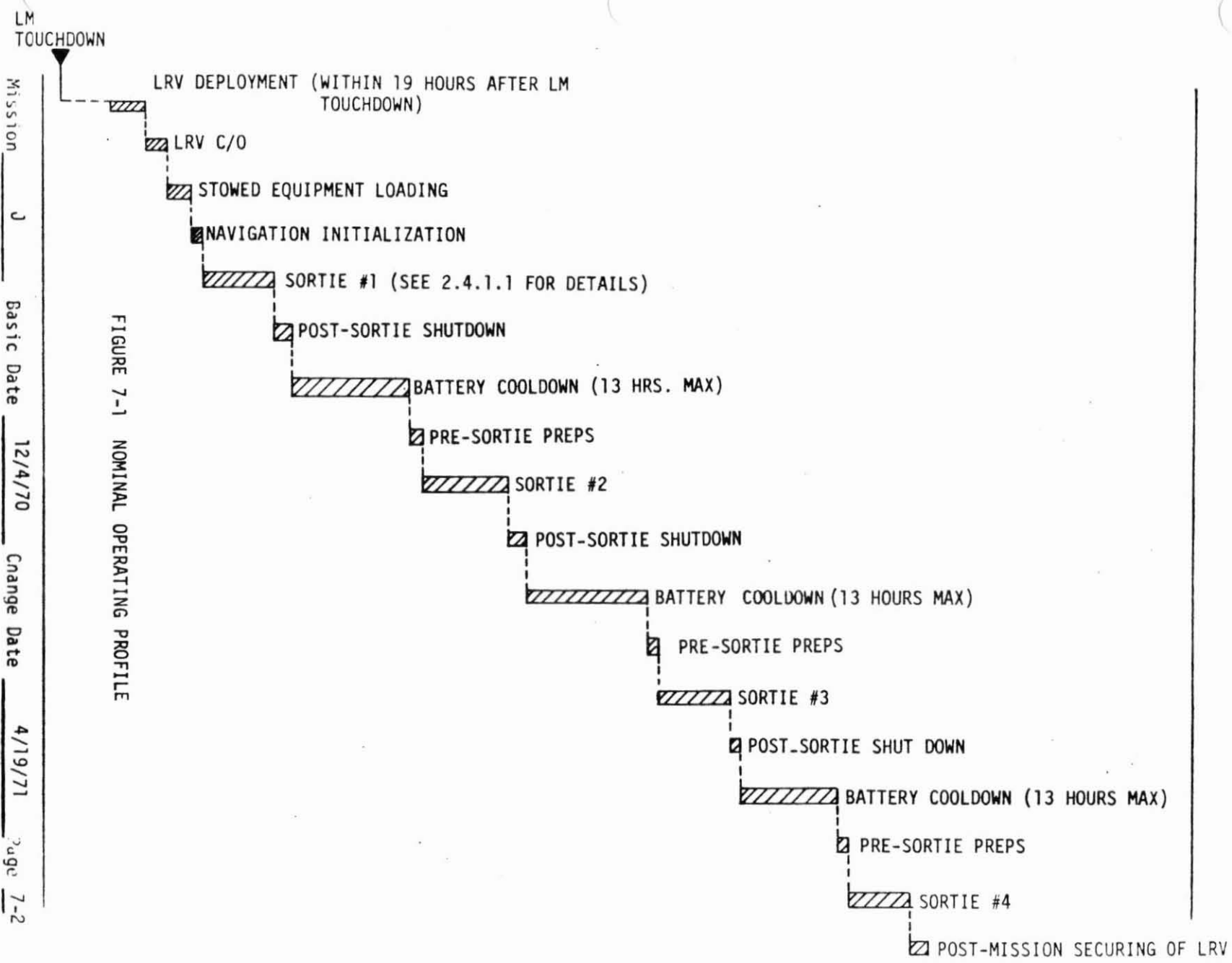

LS006-002-2H  
LUNAR ROVING VEHICLE  
OPERATIONS HANDBOOK

---

7.1.1.1 (Continued)

o Science experiment equipment will be transported by the LRV only. Operation of the science equipment will be done only when the LRV is stopped.

7.1.2 Contingency Operating Profiles

Operating profiles for contingencies depend upon the specific contingency experienced. The following paragraphs contain operating profiles for a selected number of cases.

7.1.2.1 LRV Operating Profile with Failure of Traction Drive Units

The operating profile for a contingency caused by failure of a traction drive assembly (motor or harmonic drive) would be the same as that for normal operation with the following exceptions:

- a. The specific traction drive would be uncoupled to allow "free wheeling" of that traction drive and drive power and control to that traction drive would be switched off. (Braking for the uncoupled wheel would be lost).
- b. Speed/slope capability would be limited to that shown in Appendix A.

NOTE

1. If the right rear traction drive is decoupled, the speed indication on the console speedometer will not function.
2. If two traction drives are decoupled, the navigation odometer will not function.

7.1.2.2 LRV Operating Profile with Failure of One Steering Motor

The operating profile for a contingency caused by a failure of one steering motor would be the same as for the normal profile with the following exceptions:

- a. Power to the disabled steering motor would be switched off.
- b. The steering decoupling mechanism for the disabled steering motor would be activated by the crew. (This action is reversible for the rear steering motor only).
- c. The minimum turning radius of the vehicle will be 6.2 meters as opposed to 3.1 meters with both steering motors operable.

7.1.2.3 LRV Operating Profile with Failure of One Battery

In the event of failure of one battery, all switches would be set to select the appropriate busses being supplied power from the remaining operable battery. For example, if Battery No. 1 fails, all control panel selections showing use of Bus A would be switched to select Bus C, since Bus C is supplied power from Battery No. 2. Each battery is capable of carrying the entire power load of the LRV.

LS006-002-2H  
LUNAR ROVING VEHICLE  
OPERATIONS HANDBOOK

---

7.1.2.3 (Continued)

The temperature rise in the remaining operable battery would be greater, however, causing the battery temperature to reach its upper limit in a shorter time as shown in Appendix A.

Range would be less, the specific amount depending on the point in the mission at which the failure occurs. Consult Appendix A for range capabilities.

7.2 1G TRAINER OPERATING PROFILE

7.2.1 Normal 1G Trainer Operating Profile

The 1G Trainer is designed for nominal operation in accordance with the profile shown in figure 7-2.

7.2.1.1

- o Sortie begins with fully charged batteries installed in the vehicle and enough charged batteries or chase vehicle power available to support the duration and/or length of the sortie. (See Appendix B for battery capability).
- o Science stops should be scheduled at points in the sortie corresponding time-wise, to battery change-out requirements.
- o Battery change-out will be accomplished without removing power to the navigation system when changeout must be done in mid-sortie.
- o Sortie time is not limited by trainer capability except for battery life limitations, and sun angle if sun is used for gyro update.

NOTE

Pre-calibrated check points can be used in place of sun for heading reference. This option allows use of the 1G Trainer on cloudy days, etc. and does not require ephemeris data.

- o The normal sortie will be accomplished with all four traction drives and both steering assemblies active.
- o During the sortie, stops will be made at periodic intervals to update the navigation system. At these stops the crew will also report temperatures of traction drives and batteries and state of charge of each battery.

NOTE

Navigation updates will be performed only if indicated heading differs from calculated heading by more than 2°.

- o The navigation system will remain energized throughout the sortie.
- o Driving speed during the sortie will be varied at the crew's discretion. The speed profile for the sortie leg would begin at zero, accelerate and decelerate to avoid obstacles, maintain constant speed over very smooth surfaces,

LS006-002-2H  
LUNAR ROVING VEHICLE  
OPERATIONS HANDBOOK

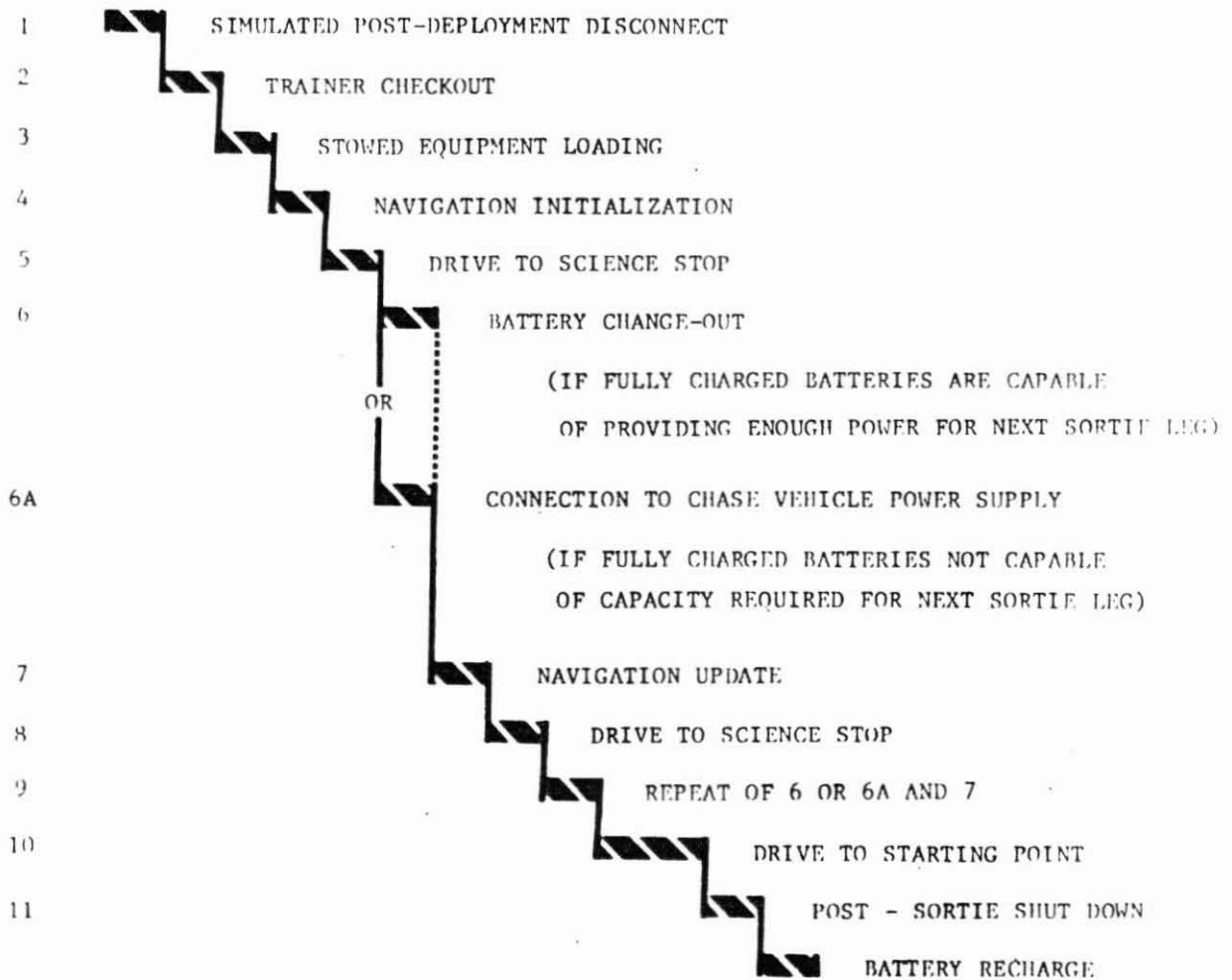

FIGURE 7-2. NOMINAL OPERATING PROFILE FOR 1G TRAINER



12 (Continued)

decelerate to observe geologic features, reaccelerate for driving and decelerating to a stop at science stations. Speed will vary between zero and 16 km/hr.

### 7.2.2 Contingency Operating Profiles

Operating profiles for contingencies depend upon the specific contingency experienced. The following paragraphs contain operating profiles for a selected number of cases.

#### 7.2.2.1 Operating Profile with Failure of Traction Drive Unit

The operating profile for a contingency caused by failure of a traction drive assembly (motor or gear box) would be the same as that for normal operations with the following exceptions:

- a. The specific traction drive would be uncoupled to allow free wheeling of that traction drive and drive power and control to that traction drive would be switched off.

#### NOTE

1. Decoupling of 1G Trainer traction drives requires a mechanic to physically do the decoupling. Simulated decoupling devices are provided for simulation of astronaut interface, but will not actually provide the decoupling. See Section 8.
2. If the right rear traction drive is decoupled, the speed indicator on the console will not function.
3. If two traction drives are decoupled, the navigation odometer will not function.

#### 7.2.2.2 Operating Profile with Failure of One Steering Motor/Gear Reducer

The operating profile for a contingency caused by a failure of one steering motor would be the same as for the normal profile with the following exceptions:

- a. Power to the disabled steering motor/gear reducer would be switched off.
- b. The steering arms would be clamped by a technician.

#### NOTE

The simulated steering decoupling rings provided for crew interface will not effect steering decoupling.

- c. Steering radius would be twice as great as with both motors operable. The driver should exercise greater caution when avoiding obstacles.

---

SECTION 8  
1G TRAINER NON-CREW  
PROCEDURES

8.0 INTRODUCTION

This section contains procedures to be performed by personnel other than crew members in support of 1G Trainer Operations. Electrical block diagrams for the 1G Trainer are provided in Figures 8-1 through 8-8.

8.1 GENERAL PROCEDURES

8.1.1 Visual Inspection

Prior to, and at the conclusion of, each sortie or mission, visually inspect the vehicle for the following:

- a. Finish or surface damage
- b. Structural integrity of parent materials, welds, and other mechanical joints
- c. Loose fasteners
- d. Electrical cable abrasion, fraying, temperature damage, shorting, loose connector
- e. Hydraulic line damage
- f. Evidence of mechanical interference
- g. Dust or debris in suspension and steering joints and bushings
- h. Brake, battery, or shock absorber leakage
- i. General configuration

**CAUTION**

Any discrepant item noted during this inspection must be corrected prior to vehicle operation.

8.1.2 General Repair

8.1.2.1 Finish or Surface Damage

All unpainted aluminum surfaces may be touched up if required by use of the processes specified in MIL-C-5541 Type I, Grade A or B, Class I. Information covering painted surfaces is carried on the appropriate piece-part drawing. Sharp nicks or any local surface deformation which could be a stress riser should be blended to the surrounding surface and refinished.

8.1.2.2 Structural Integrity

Loss of structural integrity or permanent deformation in the chassis, suspension, or any load bearing member should be considered grounds for immediate

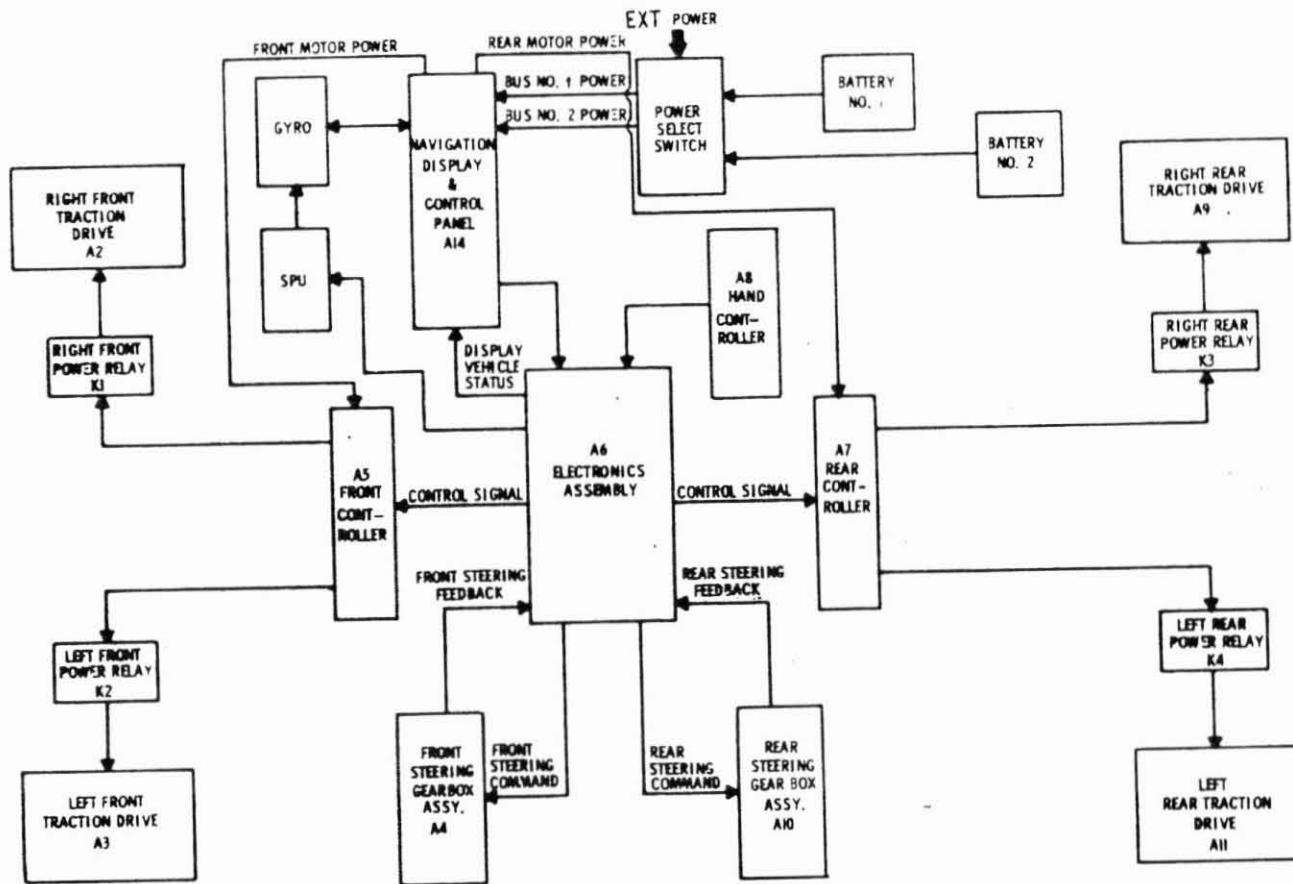

FIGURE 8-1

1G TRAINER BASIC VEHICLE BLOCK DIAGRAM

Mission \_\_\_\_\_

Basic Date 12/4/70

Change Date \_\_\_\_\_

4/19/71

Page 8-2

LS006-002-2H  
 LUNAR ROVING VEHICLE  
 OPERATIONS HANDBOOK

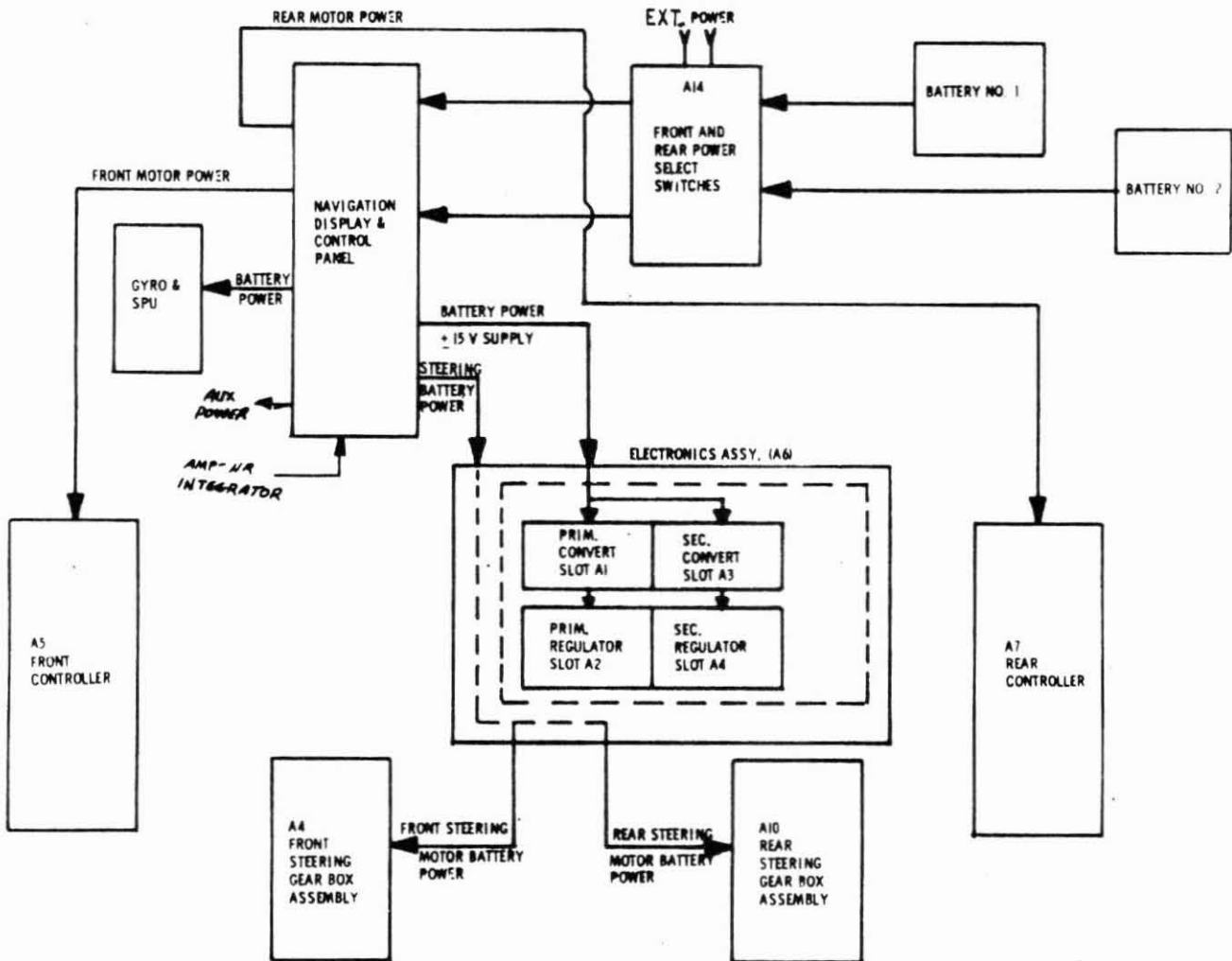

FIGURE 8-2 1G TRAINER VEHICLE POWER DISTRIBUTION BLOCK DIAGRAM

LS006-002-2H  
LUNAR ROVING VEHICLE  
OPERATIONS HANDBOOK

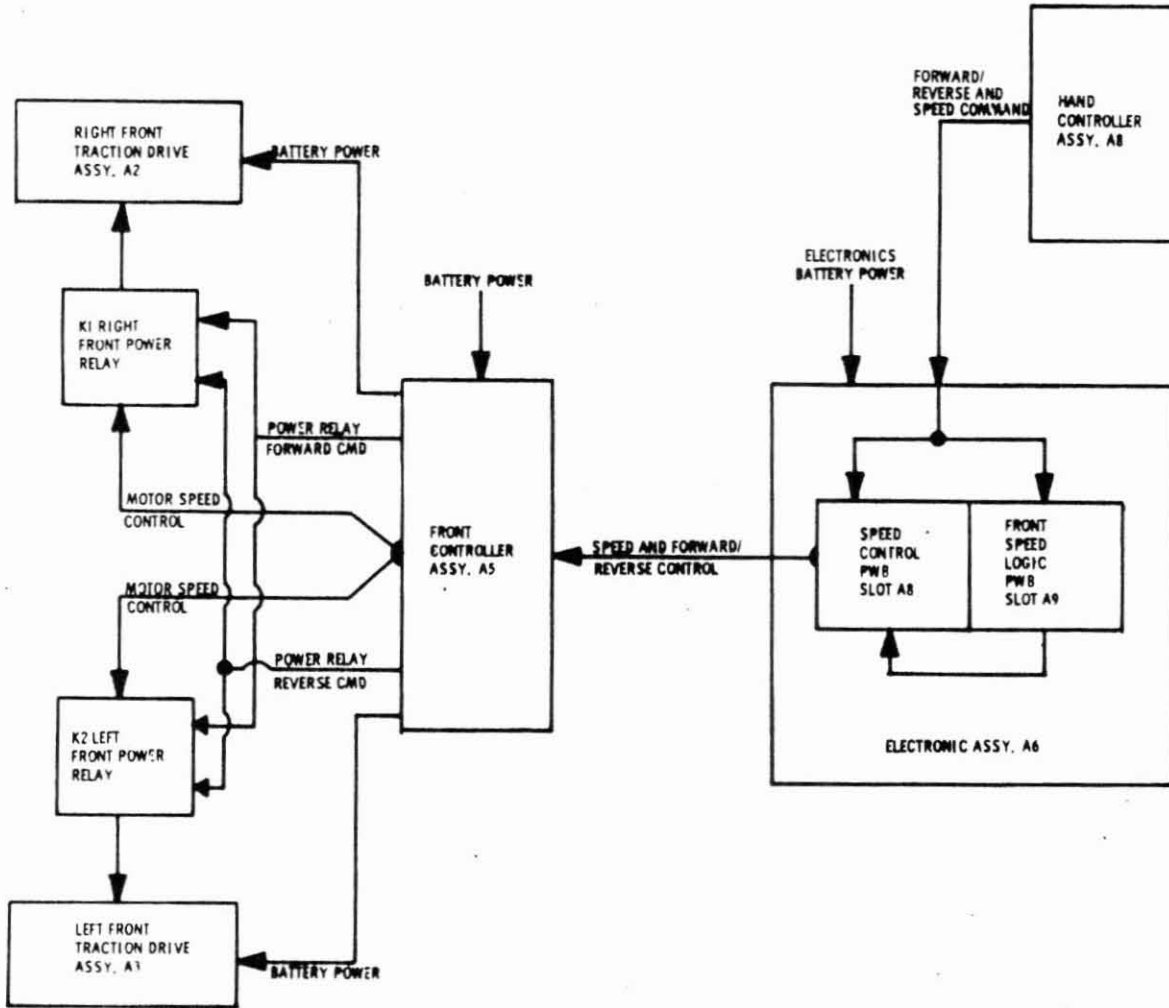

FIGURE 8-3

1G TRAINER VEHICLE FRONT TRACTION DRIVE  
ELECTRICAL SIGNAL ROUTING BLOCK DIAGRAM

LS006-002-2H  
 LUNAR ROVING VEHICLE  
 OPERATIONS HANDBOOK

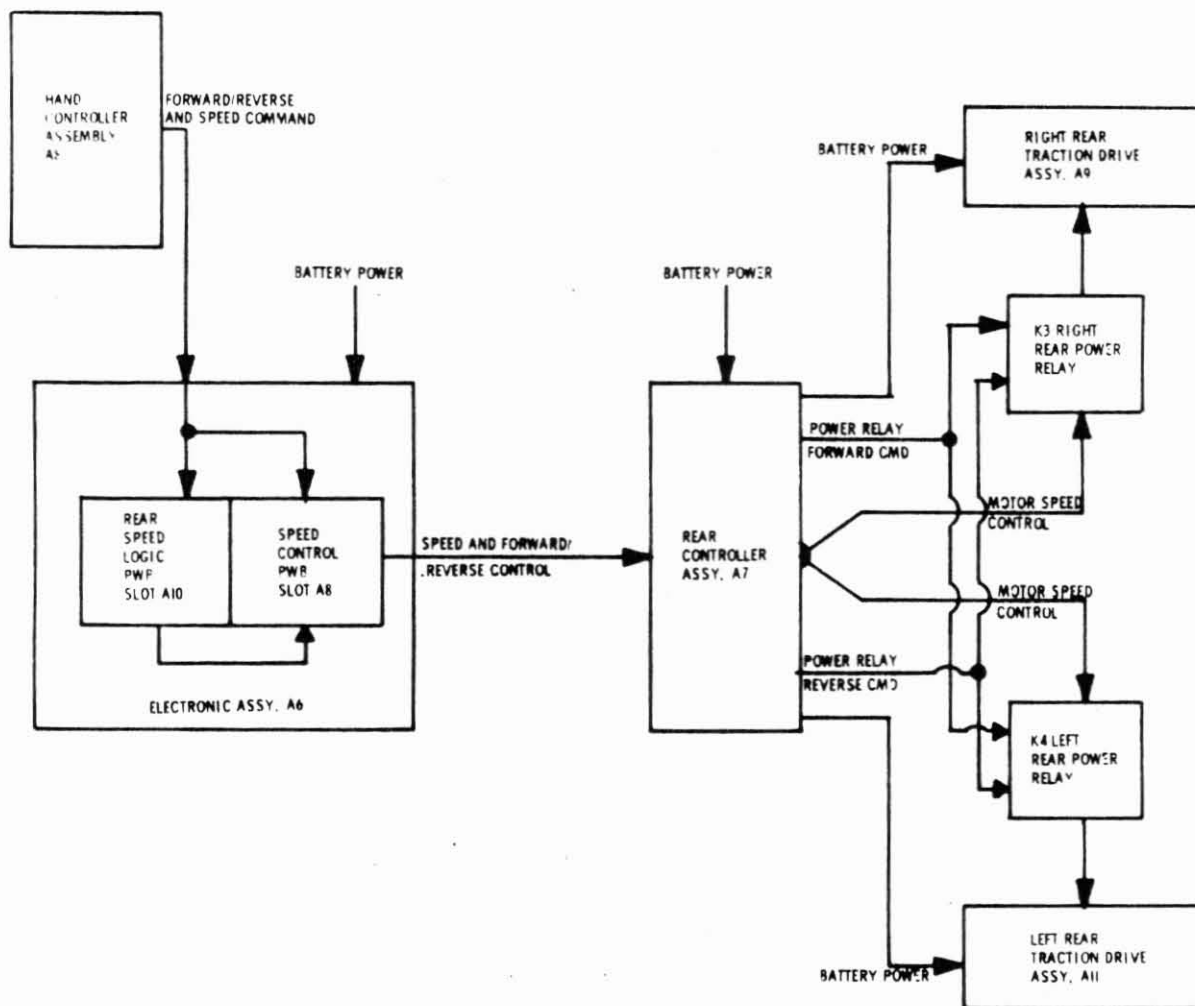

FIGURE 8-4 1G TRAINER VEHICLE REAR TRACTION DRIVE ELECTRICAL SIGNAL ROUTING BLOCK DIAGRAM

LS006-002-2H  
 LUNAR ROVING VEHICLE  
 OPERATIONS HANDBOOK

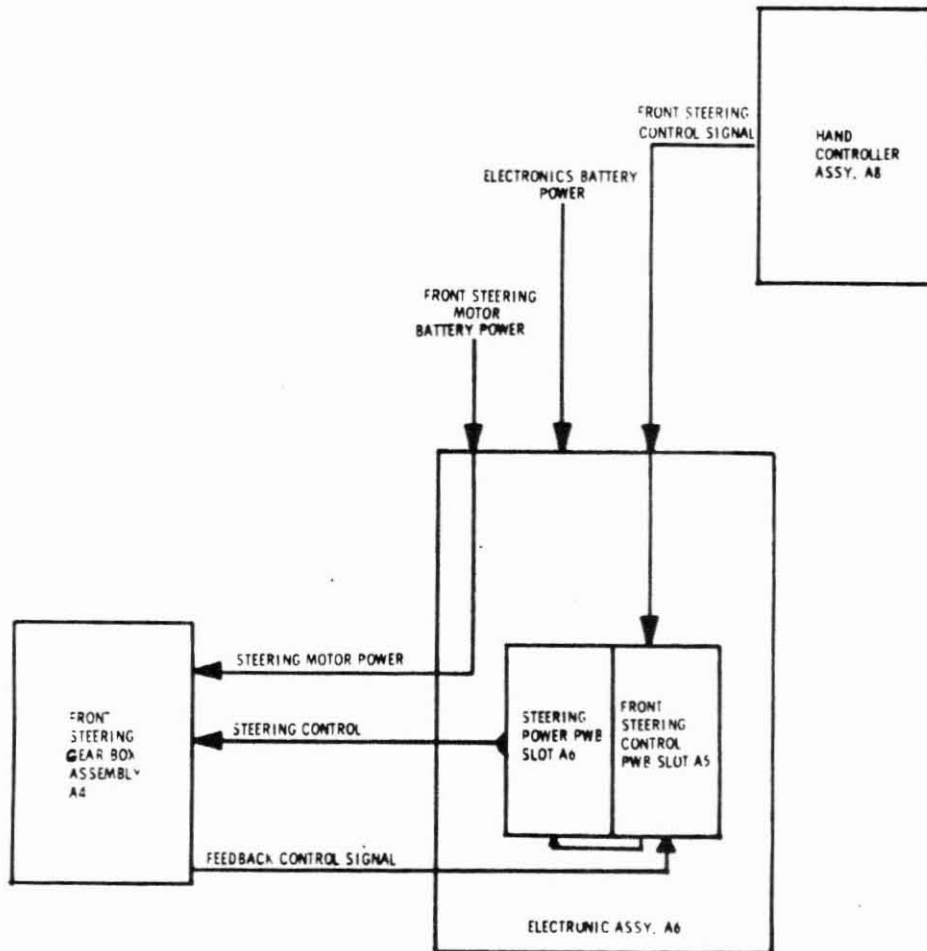

FIGURE 8-5 1G TRAINER VEHICLE FRONT STEERING  
 ELECTRICAL SIGNAL ROUTING BLOCK DIAGRAM

LS006-002-2H  
 LUNAR ROVING VEHICLE  
 OPERATIONS HANDBOOK

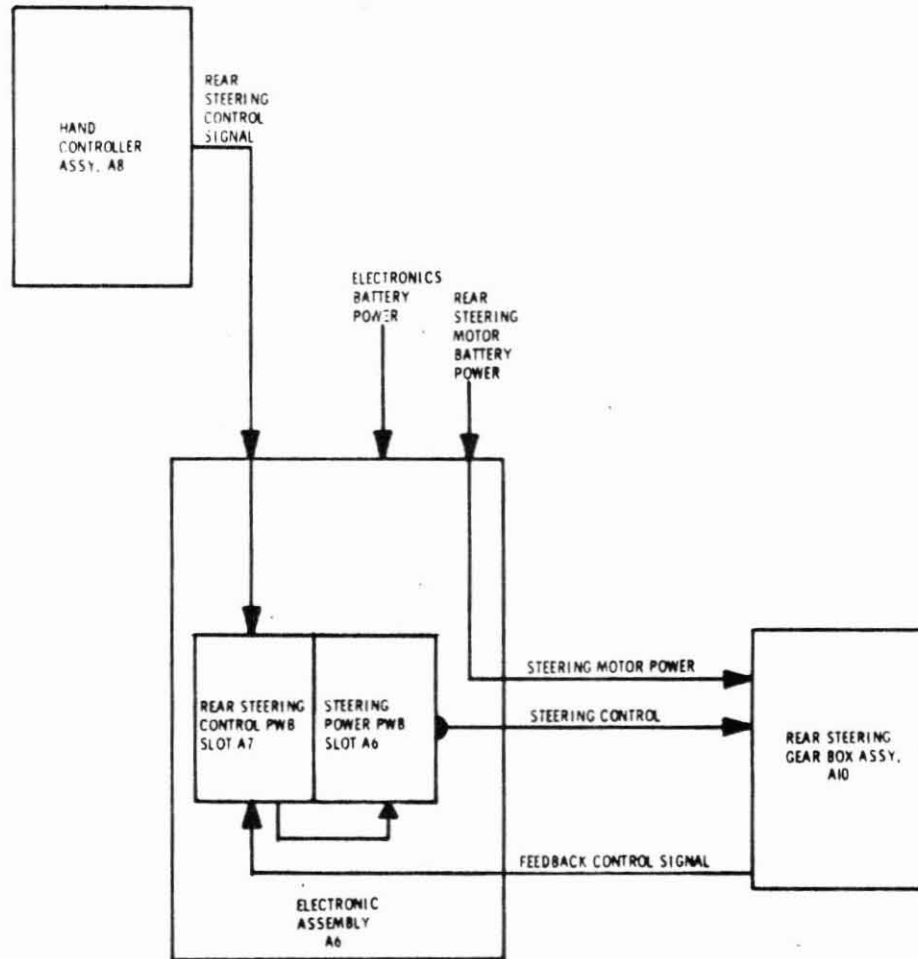

FIGURE 8-6 1G TRAINER VEHICLE REAR STEERING  
 ELECTRICAL SIGNAL ROUTING BLOCK DIAGRAM



LS006-002-2H  
 LUNAR ROVING VEHICLE  
 OPERATIONS HANDBOOK

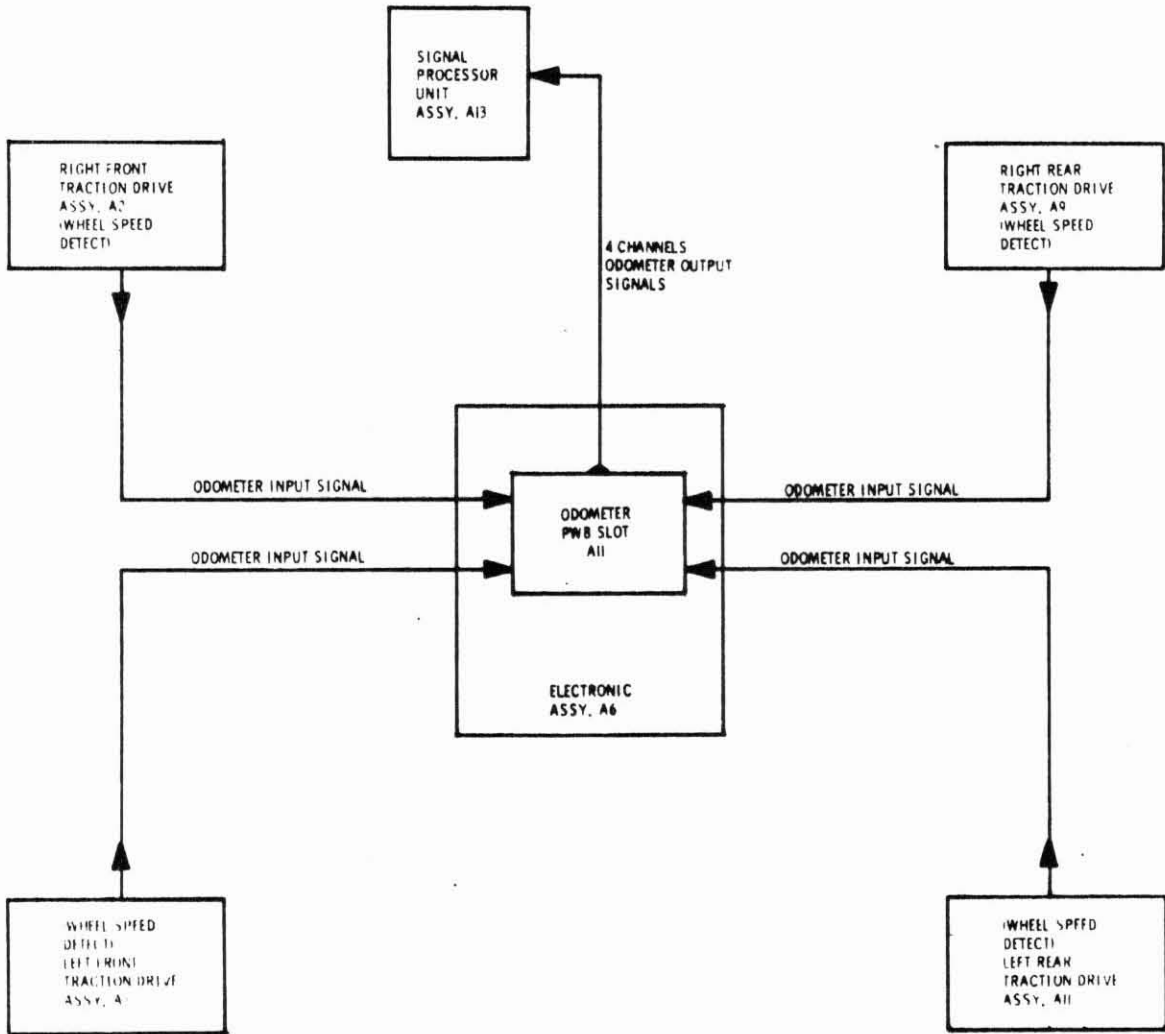

FIGURE 8-7 1G TRAINER VEHICLE ODOMETER ELECTRICAL SIGNAL ROUTING BLOCK DIAGRAM

LS006-002-2H  
LUNAR ROVING VEHICLE  
OPERATIONS HANDBOOK

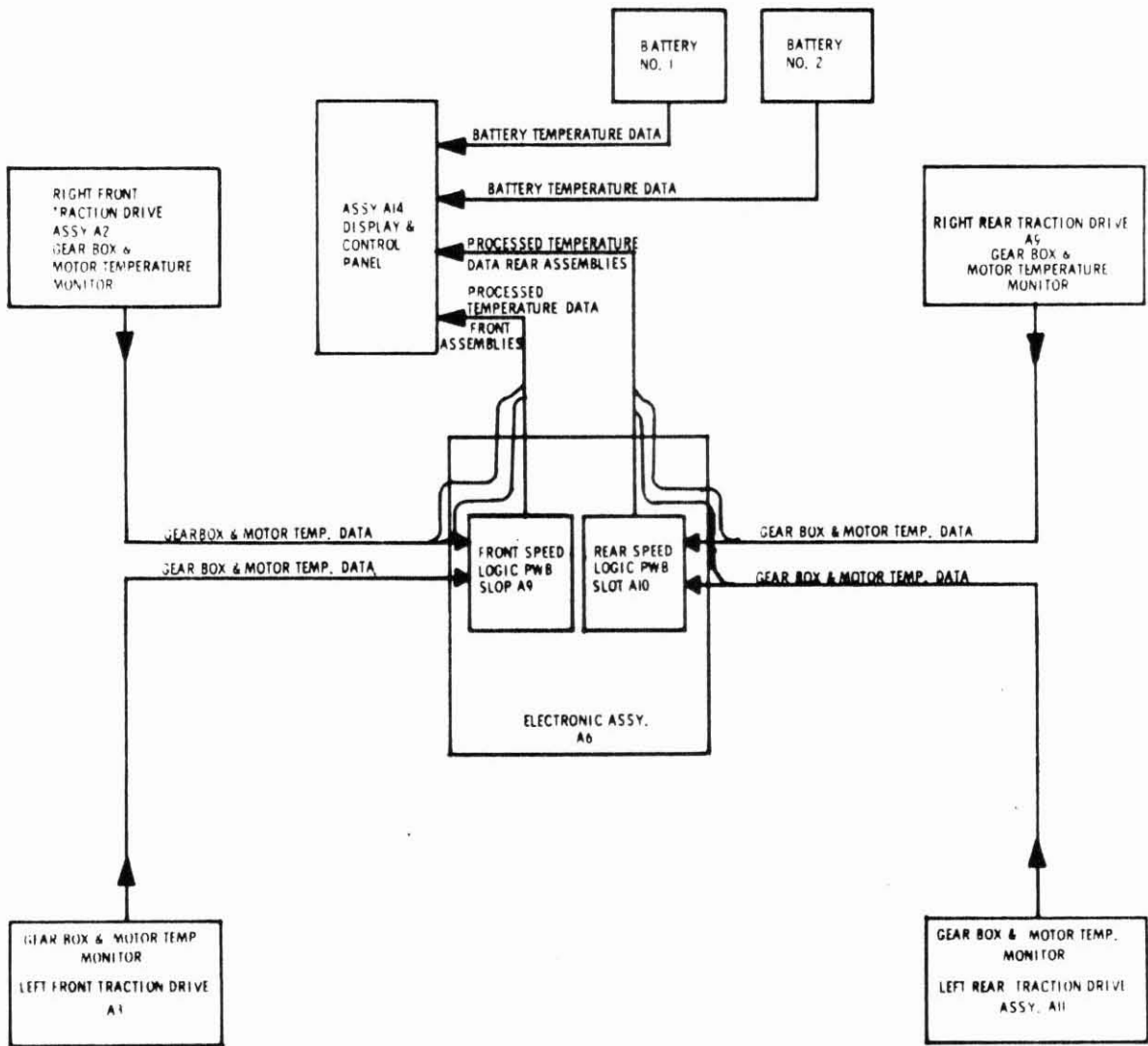

FIGURE 8-8 1G TRAINER VEHICLE TEMPERATURE DIAGNOSTICS  
ELECTRICAL SIGNAL ROUTING BLOCK DIAGRAM

#### 8.1.2.2 (Continued)

discontinuance of vehicle operation. Engineering support should be solicited for specific repair instructions.

#### 8.1.2.3 Loose Fasteners

Retighten fasteners. Replace any damaged threaded insert. Verify that the appropriate locking medium was used.

#### 8.1.2.4 Cable Damage

Replace the wire if conductor damage has occurred. If damage is limited to insulation, repair with tape, shrink tubing or a like material with insulating and moisture resistant properties similar to the original material.

#### 8.1.2.5 Hydraulic Line Damage

Repair using conventional techniques.

#### 8.1.2.6 Mechanical Interferences

Steering/suspension interference may be caused by improper gain setting (Section 8.2.3.1). Inspect interference to determine cause and treat any permanent structural deformation as a loss of structural integrity. Replace any damaged component or subassembly that has caused or resulted from the interferences.

#### 8.1.2.7 Dust or Debris

(See cleaning.)

#### 8.1.2.8 Leakage

Replace leaking component on subassembly - see cleaning.

#### 8.1.2.9 Configuration

The vehicle configuration should be as described in the top assembly drawing.

#### 8.1.3 Cleaning

At the conclusion of each vehicle mission, remove any accumulation of sand, dust, or other foreign material. Clean hydraulic fluid or like contamination with a Freon Degreaser, or equivalent. Battery electrolyte (KOH) should be treated in accordance with specific instructions (Section 8.2.8.5). Do not apply adhesive backed tape to the electrical cables because later removal may also remove the silver coating.

#### 8.1.4 Storage

- a. Long Term Storage. The vehicle should be stored inside a controlled access area wherein the ambient temperature is  $70 \pm 20^{\circ}\text{F}$  and the relative humidity does not exceed 90 percent. Batteries should be removed and stored separately. Periodic visual inspection should be made of the vehicle as defined in Section 2.1.1 and the ambient conditions should also be monitored.
- b. Short Term Storage. For overnight or other short term storage the vehicle should be covered; however, batteries need not be removed. Ambient conditions must be within a range of  $-20^{\circ}\text{F}$  to  $+120^{\circ}\text{F}$ , with relative humidity less than 100 percent.

#### 8.1.5 Safety Considerations

Vehicle operation should not be attempted by untrained personnel because of its unique control and handling characteristics. Driving skills must be developed only after a period of verbal direction and checkout, followed by actual operation under the surveillance of an instructor. Under no circumstances shall vehicle operation be other than specified in this Operation Manual.

**CAUTION**

Vehicle design specifications required that a minimum of three wheels support the vehicle at all times. Operation of the vehicle over terrain wherein two wheels support the entire vehicle may cause serious structural damage.

LS006-002-2H  
LUNAR ROVING VEHICLE  
OPERATIONS HANDBOOK

---

8.2 SPECIFIC PROCEDURES

8.2.1 Chassis

Visually inspect in accordance with Section 8.1.1. No additional adjustment or maintenance is required.

8.2.2 Hand Controller

No periodic adjustment or maintenance is required on the unit. Hand controller characteristics are shown in Figures 1-12, 1-13 and 1-14.

8.2.2.1 Lubrication and Cleaning of the Hand Controller

This operation should be done at a maximum of 300 hour intervals. Cleaning and relubricating has to be done with the hand controller removed. The slide attached to the boot should be removed from the hand controller assembly during this operation to prevent damage to the boot.

With the hand controller removed (see Section 8.3.1), clean the unit thoroughly. Clean all gear meshes and rubbing surfaces with "Freon Degreaser" cleaning fluid (dispensed from a pressurized can) or equivalent. Relubricate areas with Dow Corning "MOLYKOTE" or equivalent.

8.2.3 Suspension

Suspension clearance and alignment procedures will be required only if removal or replacement procedures have been performed on suspension and related traction drive or steering linkages. No suspension maintenance is required other than as part of the pre and post sortie visual inspection of the vehicle (Section 8.1.1).

8.2.3.1 Clearance and Alignment Adjustments

- a. Locate vehicle on level surface.
- b. Load vehicle with 520 pounds distributed as follows:
  - 245 lb. driver seat
  - 245 lb. passenger seat
  - 130 lb. equally distributed over rear

NOTE: If the vehicle includes any of the following: LCRU, high gain antenna, camera, rear-deck payload packages, the stated 130 pound rear-deck payload shall be decreased accordingly.

8.2.3.1 (Continued)

- c. Use torsion bar bracket screws to position adjustable torsion bar retainer until 35 cm minimum ground clearance exists when measured at the crew compartment corners.
- d. If inadequate adjustment exists remove the torsion bar (see Section 8.3.2) and rotate one additional spline.
- e. Apply power to both steering systems and position at electrical zero.
- f. Lay a straight edge across the center of the drive cover of both left side traction drive assemblies.
- g. If a clearance of more than 1/16 inch exists between the cover and straight edge, unlock one (or both if required) steering tie rod and adjust until straight edge is flat on both hubs.
- h. Repeat the procedure using right side traction drive assemblies.
- i. Lock tie rod nuts.
- j. Locate vehicle wheels on teflon pads or other low friction material.
- k. Attach a protractor to the drive cover of both front traction drive assemblies.
- l. Apply front steering power and electrically zero the steering.
- m. Zero the protractor, allowing adequate clearance for complete steering movement.
- n. Record steering displacement at both wheels while applying full steering command in both left and right turn direction.



Interference may occur between the wheel, fender and steering linkage.

- o. If interference occurs, adjust potentiometer R16 of printed wiring board RTV 20217 in the CW direction.
- p. Trim potentiometer R16 until inside wheel displacement is 48° minimum.
- q. Repeat procedure for rear steering.

LS006-002-2H  
LUNAR ROVING VEHICLE  
OPERATIONS HANDBOOK

---

8.2.3.1 (Continued)

Acceptance test data on steering operation and hand controller position versus wheel angles is presented in Table 8-1 for reference only.

8.2.4 Traction Drive

No Traction Drive adjustments are required; however, each unit can be mechanically decoupled to simulate LRV degraded operation or to permit towing without back-driving the motors (see Section 8.2.5.3, a through c). The preventive maintenance described in sections 8.2.4.1 through 8.2.4.3 is necessary.

8.2.4.1 Pre and Post Mission

Visually inspect per Section 8.1.1.

8.2.4.2 Every 50 Hours of Operation

Clean air filter as follows:

- a. Remove traction drive blower.
- b. Remove filter material.
- c. Clean or wash in water.
- d. Dry and re-install.

8.2.4.3 Every 200 Hours of Operation

Relubricate gearbox as follows:

- a. Remove traction drive assembly from the vehicle.
- b. Remove hub assembly with drive cover and outer bearing by removing the eight brake disc screws.
- c. Secure brake disc to king pin by tying two places, using hub mounting screw holes.
- d. Disconnect gearbox thermostat retainer band.
- e. Remove any cable clamps, ties or restraints as needed and work gearbox thermostat cable through gearbox flange as far as possible.
- f. Remove gearbox mounting screws.

**CAUTION**

Do not remove the brake disc and seal or damage the thermostat cable.

- g. Remove the three planetary stages and degrease.
- h. Degrease the gear housing.

Mission

J

Basic Date

12/4/70

Change Date

4/19/71

Page

8-15

| Steering Proportionality |   |          |          |          |
|--------------------------|---|----------|----------|----------|
| Hand Controller Angle    | Degrees Rotation of Wheel from Neutral Position |          |          |          |
|                          | LF Wheel  | RF Wheel | LR Wheel | RR Wheel |
| Right Soft Stop (S. S)   | 15  | 26       | 28       | 16-1/2   |
| Right H. S.              | 19-1/2  | 49-1/4   | 48       | 21-1/4   |
| Left S. S.               | 29  | 17-1/2   | 16       | 26       |
| Left H. S.               | 48-1/2  | 21-1/2   | 21       | 51-1/2   |

- NOTES: 1. DATA IS FOR REFERENCE ONLY  
 2. DATA IS FROM 1G TRAINER ACCEPTANCE TEST

TABLE 8-1 1G TRAINER STEERING OPERATION DATA



LS006-002-2H  
LUNAR ROVING VEHICLE  
OPERATIONS HANDBOOK

---

8.2.4.3 (Continued)

- i. Repack all planetary gears and bearings with RTV 21119-001 lubricant.
- j. Reassemble gearbox and verify that the output stage bearing is seated against the retaining ring.
- k. Re-assemble.

8.2.5 Wheels

Wire wheels or pneumatic tires may be interchanged as sets.

8.2.5.1 Wire Wheels

Visually inspect in accordance with Section 8.1.1. Discontinue wheel use when wire breakage approaches 200 wires. Loose tread strips may be wired in place, since disassembly is not practical.

8.2.5.2 Pneumatic Tires

Visually inspect in accordance with Section 8.1.1. Repair, using conventional commercial tire techniques. For most operations inflate the tire to 30 psig - approximately 13.9 inch rolling radius (as measured from the hub center to the operating surface). Do not exceed 40 psig. Air pressure may be reduced for soft soil operation.

8.2.5.3 Wheel Decoupling

This procedure is for decoupling any of the four wheels. Nonfunctional decoupling clips are installed on each wheel for LRV simulation. The actual decoupling is accomplished by replacing drive hubs with blanks.

- a. Hand Controller - parking brake position with throttle control in neutral.
- b. DRIVE POWER Switches (4) - OFF.
- c. STEERING Switches (2) - OFF.
- d. + 15 VDC Switch - OFF.
- e. Remove the six Phillips-head screws from the hub of the wheel to be decoupled (figure 8-9).
- f. Remove the drive hub.
- g. Obtain a blank "decoupling" hub.
- h. Insert the blank hub into the wheel.
- i. Install the six screws into the blank hub to secure the hub to the wheel.
- j. Notify crew to resume operation.

8.2.6 Brakes

8.2.6.1 Brake Adjustments - Maximum Stopping Effort

- a. Install long master cylinder actuating levers on both cylinders and connect external springs.

LS006-002-2H  
LUNAR ROVING VEHICLE  
OPERATIONS HANDBOOK

---

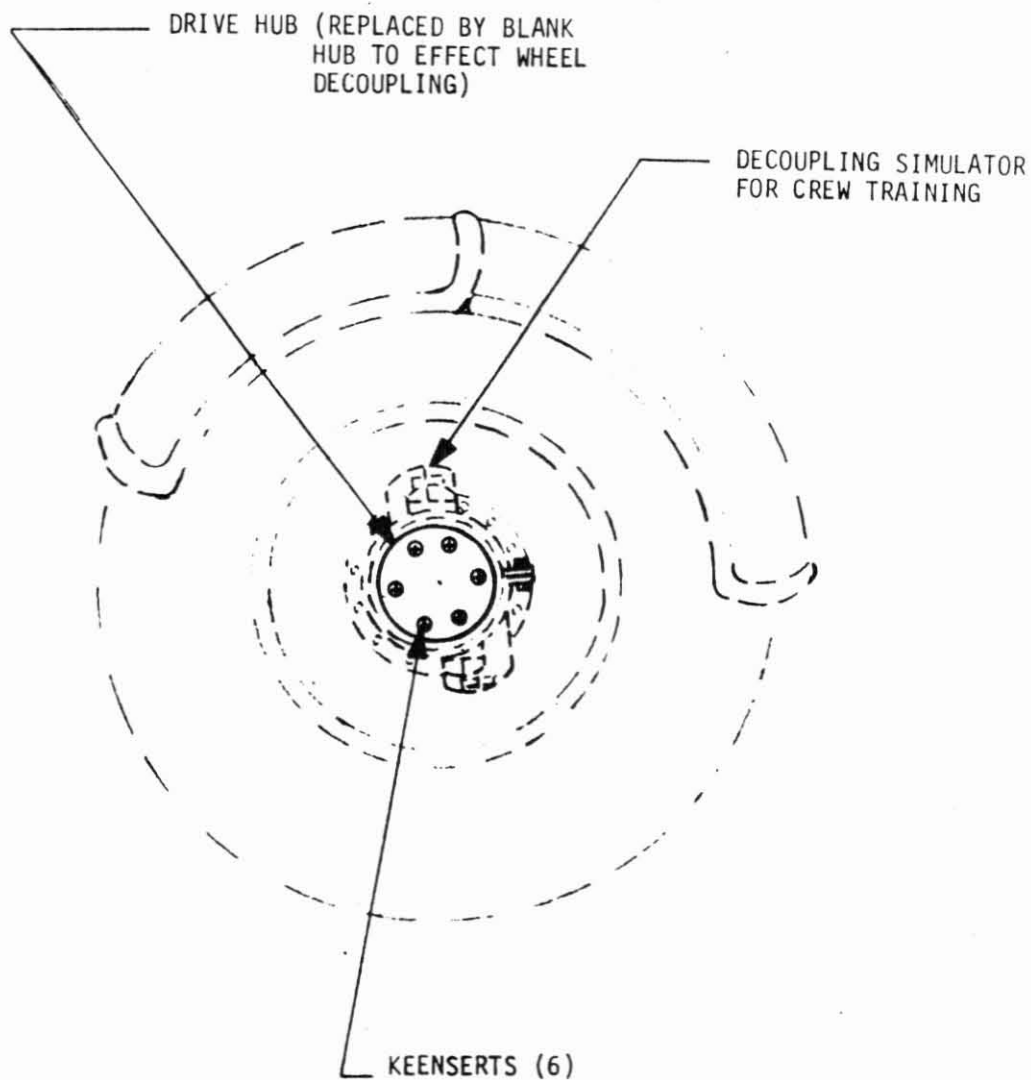

TYPICAL FOR ALL FOUR WHEELS

FIGURE 8-9 1G TRAINER WHEEL DECOUPLING

LS006-002-2H  
LUNAR ROVING VEHICLE  
OPERATIONS HANDBOOK

---

8.2.6.1 (Continued)

NOTE: If lever operation results in a spongy effect or in brakes with leak down, bleed the system of entrapped air before proceeding.

- b. Connect cable clevis to the top lever holes.
- c. With the hand controller forward (brakes off), concurrently adjust cable lengths at the hand controller yoke for both master cylinders.
  - (1) Maintain horizontal position of the yoke (equalized load).
  - (2) Adjust length until the brake pulley position is as shown in Figure 8-10. Maintain corresponding relative rotational position between pulleys.
  - (3) Maintain clearance between the actuation lever and the master cylinder piston with clevis adjustment.
- d. Remove master cylinder covers and verify fluid level.
- e. Concurrently adjust the actuation lever position (with the clevis) until no clearance exists between the lever and piston. Continue to adjust until application and release of the brakes with the hand controller results in the absence of an oil spout in the fluid reservoir.
- f. Readjust the clevis(es) the minimum amount necessary for consistent occurrence of the oil spout.
- g. Re-verify fluid level and install the reservoir cover.
- h. Braking effort may be verified as follows:
  - (1) Adapt a 200 ft. lb. capacity torque wrench to the center of a blank traction drive cover, RTV 20613. (A 5/8 diameter high strength socket head bolt may be used).
  - (2) Install adapted cover in place of any existing drive cover.
  - (3) Remove vehicle weight from the traction drive.
  - (4) Set the hand controller to the park position.
  - (5) Attach torque wrench with 7/8 inch socket to the adapter cover.
  - (6) Torque with wrench until the wheel rotates - indicated value should be approximately 195 ft. lbs.

NOTE: If substantially less torque is measured the nonlinear pulley may be incorrectly positioned and the procedure should be repeated starting at Step 8.2.6.1.c.

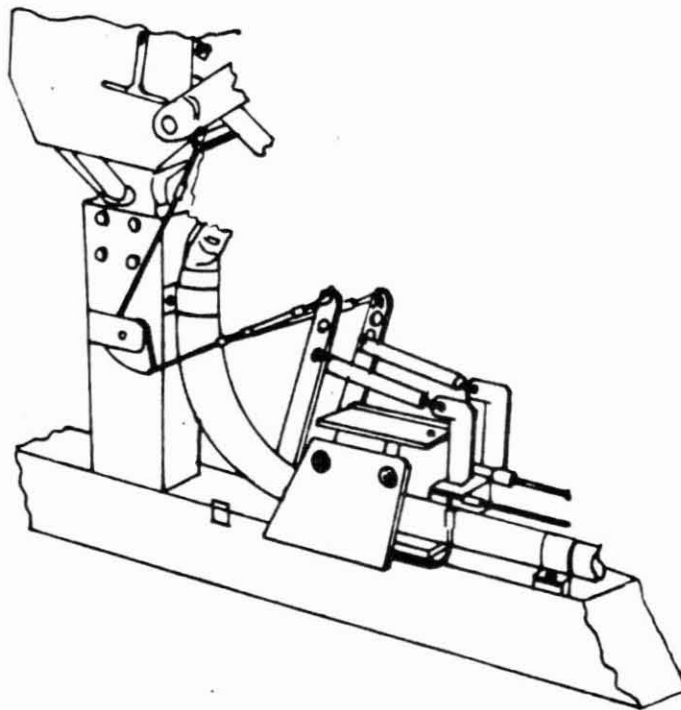

FIGURE 8-10 1G TRAINER BRAKE LINKAGE

LS006-002-2H  
LUNAR ROVING VEHICLE  
OPERATIONS HANDBOOK

---

8.2.6.2 Brake Adjustments - Degraded Operation

- a. Install long master cylinder actuating levers on both cylinders and connect external springs. Verify reservoir fluid level.

NOTE: If lever operation results in a spongy effect or in brakes which leak down, bleed the system of entrapped air before proceeding.

- b. Connect cable clevis to the lower lever holes.
- c. With the hand controller forward (brakes off), concurrently adjust cable lengths at the hand controller yoke for both master cylinders.
- (1) Maintain horizontal position of the yoke (equalized load).
  - (2) Adjust length until the brake pulley position is as shown in Figure 8-10. Continue adjustment, shortening cable length to maximum amount possible. Maintain corresponding relative rotational position between pulleys.
  - (3) Maintain clearance between the actuation lever and the master cylinder piston with clevis adjustment.
- d. Concurrently adjust the actuation level position (with the clevis) until no clearance exists between the lever and piston.
- e. Braking effort may be verified as follows:
- (1) Adapt a 200 ft. lb. capacity torque wrench to the center of a blank traction drive cover, RTV 20613. (A 5/8 inch diameter high strength socket head bolt may be used).
  - (2) Install adapted cover in place of any existing drive cover.
  - (3) Remove vehicle weight from the traction drive.
  - (4) Set the hand controller to the park position.
  - (5) Attach torque wrench with 7/8 inch socket to the adapter cover.
  - (6) Torque with wrench until the wheel rotates - indicated value should be approximately 60 ft. lbs.

NOTE: If substantially more torque is measured, install short master cylinder actuating levers and repeat the procedure.

8.2.7 Steering Unit

No adjustments are required to the steering gearboxes after installation.

8.2.7.1 Clean and Relubricate Steering Gearboxes

This operation should be done at not less than 50 hour or more than 300 hour intervals. Because of the inaccessibility of the front steering unit, clean and lubrication procedure should be accomplished, if the front cover panel

LS006-002-2H  
LUNAR ROVING VEHICLE  
OPERATIONS HANDBOOK

---

8.2.7.1 (Continued)

has to be removed for other service operations (not to exceed 50 hours as mentioned previously).

Cleaning the steering gearboxes should be done by first blowing out any dirt or dust with compressed air. Gears are to be cleaned with "Freon Degreaser" fluid or equivalent. Relubricate the gear teeth with Dow Corning "MOLYKOTE" or equivalent.

8.2.7.2 Steering Decoupling

- a. Verify the crew has manually positioned the forward or rear wheels (whichever is to be simulated as the decoupled wheels) to the straight ahead position.
- b. Hand Controller - parking brake position with throttle control in neutral.
- c. DRIVE POWER Switches (4) - OFF.
- d. STEERING Switches - OFF.
- e. Obtain two steering arm clamps.
- f. Place steering arm clamp on the left and right hand steering arms, in such a position that the clamps are butted against the outside of the chassis frame where the steering arms pass through the frame (figure 8-11).
- g. Open the FORWARD STEERING Circuit Breaker on the display and control console if forward steering arms were clamped. Open the REAR STEERING Circuit Breaker if the rear steering arms were clamped.
- h. Notify crew to resume operation.

8.2.8 Drive Power

The Drive Power Subsystem consists of a Control Electronics package, two Drive Controllers, and two 34 VDC Ni-Cad batteries.

8.2.8.1 Control Electronics

No periodic adjustment or maintenance is required. Inspect the exterior in accordance with Section 8.1.1

8.2.8.2 Drive Controller

No periodic adjustment or maintenance is required. Inspect the exterior in accordance with Section 8.1.1.

LS006-002-2H  
LUNAR ROVING VEHICLE  
OPERATIONS HANDBOOK

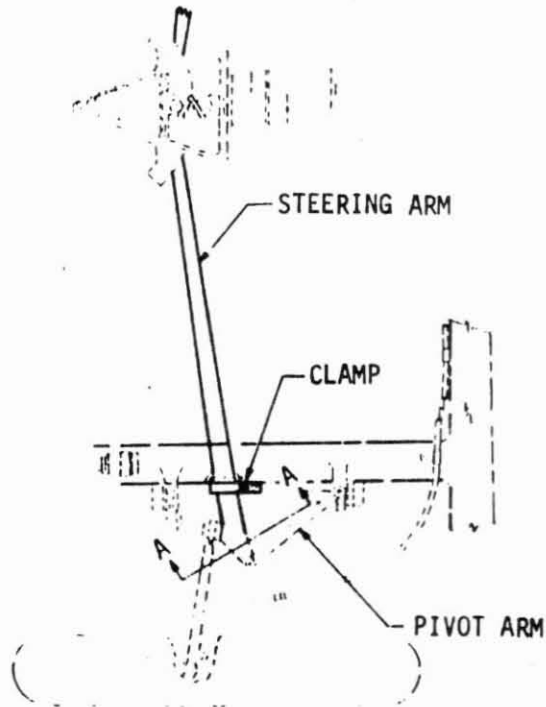
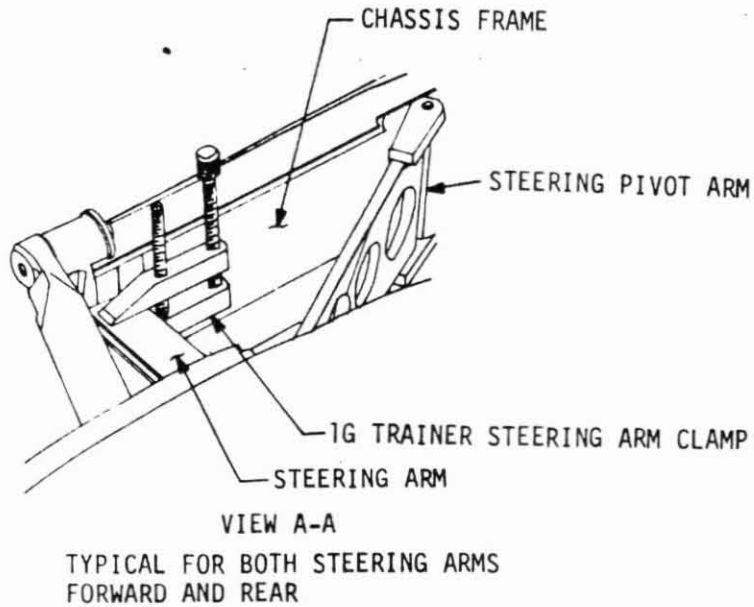

FIGURE 8-11 1G TRAINER STEERING ARM CLAMPING  
TO SIMULATE STEERING DECOUPLING

### 8.2.8.3 Battery Change-Out

Changeout of 1G Trainer batteries can occur in two different operational conditions: (1) when the navigation system is to remain on during changeout, and (2) when the navigation system may be off during changeout. The following procedures define both cases.

a. When the navigation system is to remain on:

- 1) DRIVE POWER Switches (4) - OFF.
- 2) STEERING Switches (2) - OFF.
- 3) + 15VDC Switch - OFF.

#### NOTE

1G Trainer Battery #1 is on the right side,  
Battery #2 on the left side.

- 4) If changing out Battery #1, open BAT 1 BUS A and BAT 1 BUS B circuit breakers. Do not open the BAT 2 circuit breaker or navigation power will be lost.
- 5) If changing out Battery #2, open BAT 2 BUS C and BAT 2 BUS D circuit breakers. Do not open the BAT 1 circuit breakers or navigation power will be lost.
- 6) Place power selector switch (figure 8-12) for the battery to be changed out in the OFF position. Do not operate the selector switch for the other battery.
- 7) Disconnect the battery connector from the battery to be changed out (figure 8-12).
- 8) Remove the four screws from the battery mounting bracket.
- 9) Lift the battery clear of the 1G Trainer using the handles at either end of the battery.
- 10) Obtain recharged replacement battery.
- 11) Set the replacement battery in place with the connector inboard and the holes in the mounting brackets aligned with the screw receptacles in the 1G Trainer.
- 12) Install the four screws, securing the battery to the 1G Trainer.
- 13) Connect the battery connector to the battery.



LS006-002-2H  
LUNAR ROVING VEHICLE  
OPERATIONS HANDBOOK

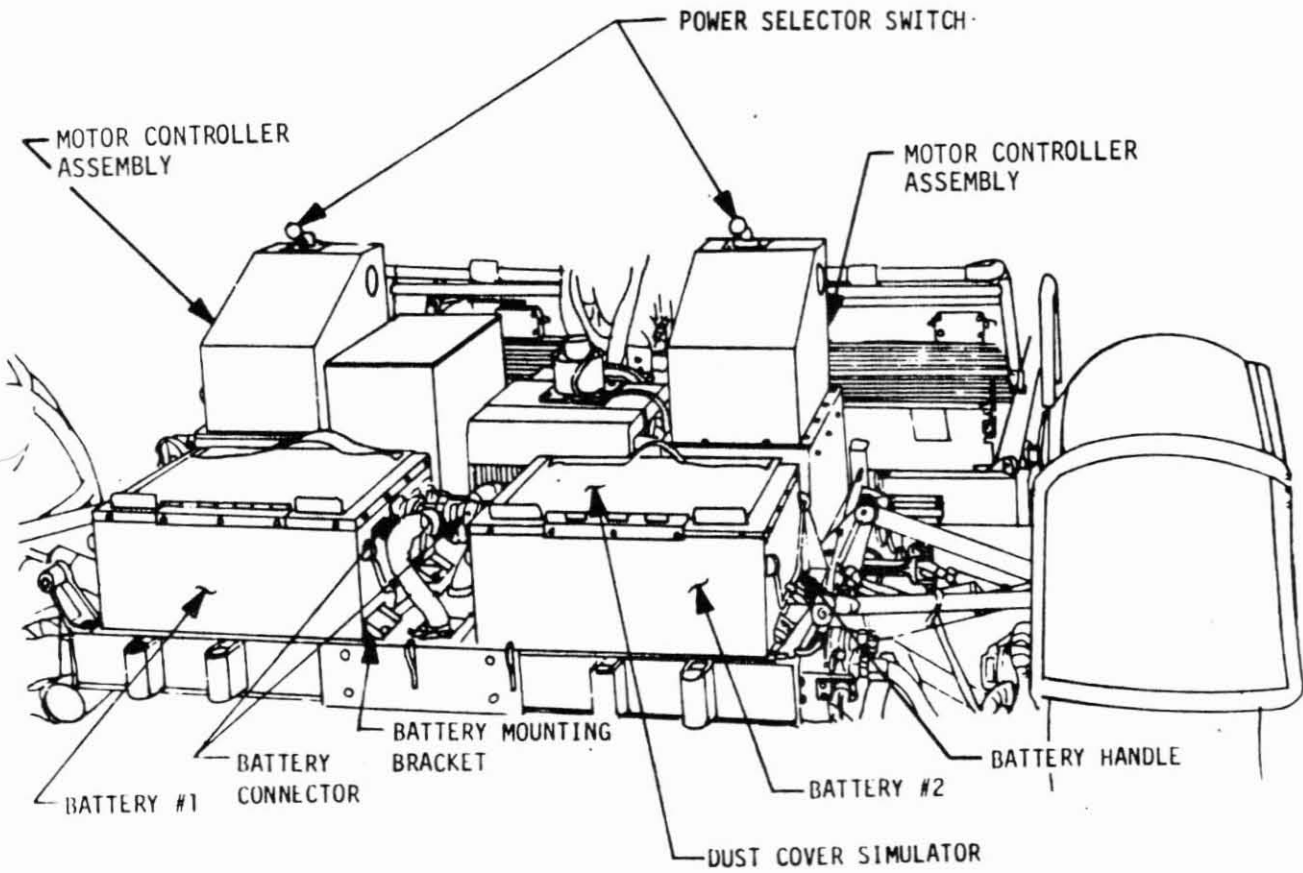

FIGURE 8-12 1G TRAINER BATTERY INSTALLATION

LS006-002-2H  
LUNAR ROVING VEHICLE  
OPERATIONS HANDBOOK

---

8.2.8.3 (Continued)

- 14) Place the power selector switch in the BATTERY position.
  - 15) If Battery #1 was changed out close BAT 1 BUS A and BAT 1 BUS B circuit breakers on the control and display console.
  - 16) If Battery #2 was changed out, close BAT 2 BUS C and BAT 2 BUS D circuit breakers on the control and display console.
  - 17) Repeat steps 4 through 16 for the other battery.
- b. When the navigation system may be off:
- 1) DRIVE POWER Switches - OFF.
  - 2) STEERING Switches - OFF.
  - 3) + 15 VDC Switch - OFF.
  - 4) Circuit Breakers BAT 1 BUS A, BAT 1 BUS B, BAT 2 BUS C, BAT 2 BUS D - Open.
  - 5) Place power selector switches in OFF position.
  - 6) Perform step a7 through a14 for both batteries.
  - 7) Close BAT 1 BUS A, BAT 1 BUS B, BAT 2 BUS C, BAT 2 BUS D Circuit Breakers.
- c. If required to perform dust cover simulation, remove dust covers from one set of batteries and install on replaced batteries.

8.2.8.4 Battery Recharging

Each battery will be discharged to a condition below 29 volts when seven amps current exists.

- a. Remove closure cover and all plastic fill caps.
- b. Verify presence of low-pressure relief vent screw in each fill-cap.
- c. Connect a charging circuit equivalent to Figure 8-13.
- d. Set power supply current limiter to provide 14 amps.
- e. Energize the power supply and adjust voltage to provide 14 amps out of the supply.
- f. Maintain condition specified in "e" for a period of 2 hours. Adjust voltage as required for constant current charging.
- g. Set power supply to provide  $+45.5 \pm 0.2$  vdc and maintain the current limiter setting of 14 amps.

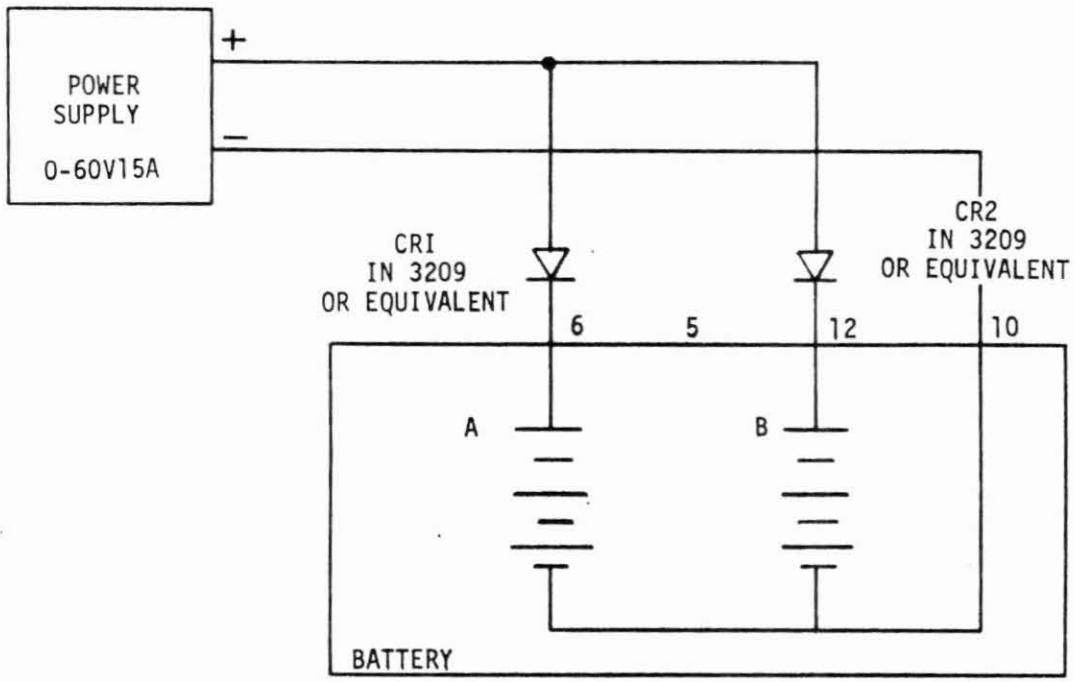

FIGURE 8-13 1G TRAINER BATTERY CHARGING CIRCUIT

8.2.8.4 (Continued)

- h. Allow batteries to charge for 4 hours or until the current flow is less than 2.0 amps.
- i. Remove the charging circuit from the battery.
- j. Using the VOM, measure the open-circuit voltage. Voltage should be greater than +35 VDC.
- k. Check and verify that the level of electrolyte in each cell is visible at the bottom of the funnel-shaped inner chamber.
- l. Using a syringe, carefully add distilled water to each cell if necessary to bring electrolyte to the proper level.
- m. After charging, the batteries shall be carefully rinsed with distilled water.
- n. After rinsing, the batteries shall be dried.
- o. Remove batteries from setup, install closure cover, and secure from test.

8.2.8.5 Precautions for Handling Batteries and Electrolyte

The electrolyte (KOH) is alkaline and corrosive. It should be handled with care, since it will cause serious burns if allowed to contact eyes or skin.

At stations where handling is done, a supply of boric acid, for eye-burns, and a solution of weak acid (5% acetic acid) for skin burns should be maintained.

Persons who work with batteries should wash their hands thoroughly after handling them.

Persons who fill batteries or otherwise handle electrolyte should wear alkali-proof aprons, gloves, and a face mask.

KOH can cause ignition between points of sufficiently high potential difference. Fire extinguishers should be available during battery operation and servicing.

Batteries should not be lifted by one man.

8.3 PREVENTIVE MAINTENANCE ASSEMBLY REMOVE AND REPLACE PROCEDURES

8.3.1 Removal and Replacement of the "Hand Controller"



During this operation do not put tape of any kind on the electrical cables. The tape will remove the silver from the protective cable cover.

Removal is accomplished in the following manner:

- a. Cut brake release cable (the small cable that extends rearward from the hand controller mount).
- b. Detach electrical cables from Display and Control Console. Cut cable ties as required.
- c. Remove brake cables.
- d. Remove the display console from its base. Remove the console base by removing the two "T" pivot handle pins and the two clevis pins at the rear of the console base.
- e. Uncouple the electrical connections at the base of the hand controller.
- f. Remove the four side plate mounting screws.
- g. Remove the four screws from the base of the hand controller.

8.3.2 Suspension/Traction Drive - Removal and Installation Procedure

- a. Remove weight from wheel by suspending vehicle at lift points, after measuring ground clearance.
- b. Remove wheel disconnect simulator.
- c. Remove wheel and fender.
- d. Disconnect steering tie rod at steering hinge.
- e. Disconnect traction drive cables.
- f. Disconnect brake hoses, if traction drive is to be moved from area.

LS006-002-2H  
LUNAR ROVING VEHICLE  
OPERATIONS HANDBOOK

---

8.3.2 (Continued)

- g. Loosen torsion bar adjustment screw - one only.
- h. Remove torsion bar cover screws/cover at outboard suspension bracket.
- i. Remove torsion bar.

NOTE: Torsion bars are not completely interchangeable (cross corners only) and each should be marked with respect to suspension fitting to assure the same ground clearance upon re-assembly.

- j. Remove top and bottom king pin screws and flat washers.
- k. Remove traction drive.
- l. Remove shock absorber. (May be removed without prior steps if shock absorber is only service item.)
- m. Remove upper suspension attachment hardware at suspension mounting brackets.
- n. Remove outboard suspension brackets. Also remove inboard suspension bracket if service is required.
- o. Remove suspension arms.
- p. Remove suspension to king pin links (both arms), if service of parts required.
- q. To remove inboard torsion bar brackets (with adjustable retainer), remove frame mounting screws and remove from the bottom. Adjustable retainer may be removed by disassembling the torsion bar bracket.

NOTE: Torsion bar brackets are line bored with suspension brackets and are not interchangeable.

- r. The fixed torsion bar retainer may be replaced in the lower suspension by pressing out dowel pins in the flange and unscrewing fitting.

NOTE: Fixed retainers are drilled on assembly and are not interchangeable.

LS006-002-2H  
LUNAR, ROVING VEHICLE  
OPERATIONS HANDBOOK

---

8.3.2 (Continued)

Inspect all parts for wear or damage. To reassemble, reverse above procedure.  
Also:

- s. Drill link pins on assembly if replaced.
- t. Tighten only the torsion bar adjustment screw that was loosened in step 8.3.2g.
- u. Realign wheels if new traction drive or steering linkage installed.
- v. Bleed brakes if lines have been opened.
- w. Verify proper ground clearance as recorded during disassembly.

8.3.3 Drive Power - Removal and Installation Procedure

- a. Remove batteries (see Section 8.2.8.3).
- b. Loosen set screw in off-on charge switch handle and remove.
- c. Remove all cover screws and hold down screws on filter cover and controller assembly.
- d. Disconnect wires (4) from top of filters.
- e. Disconnect wires (5) from rear of switch assembly which come from controller below.
- f. Tip filter and switch to one side and disconnect wires (4) from lower side of filters.
- g. Remove switch and filter assembly, allowing disconnected wires to flow through holes in lower switch and filter plate.
- h. Remove wires from TBI inside controller box. (Only wires which come from inside trainer chassis should be removed.)
- i. Nuts and washers should be counted as it is important not to lose any hardware inside controller box or a short circuit may result.
- j. Disconnect P2 cannon connector.
- k. Remove controller box by lifting and feeding wires through hole in bottom of box.
- l. Remove Control Electronic mounting screws, disconnect cables routed into the box from below, and remove package.
- m. Install units in reverse of removal.

LS006-002-2H  
LUNAR ROVING VEHICLE  
OPERATIONS HANDBOOK

---

8.3.4 Steering Gearbox Removal and Installation Procedure

- a. Remove Drive Power units as described in Section 8.3.3.
- b. Remove transverse structural support member RTV21103.
- c. Disconnect cables and remove signal processor unit.  
NOTE: Thermal controls are hard wired and may require unsoldering.
- d. Disconnect cables and remove gyro reference unit with mounting brackets.  
NOTE: Thermal controls are hard wired and may require unsoldering.
- e. Detach cables from the front cover panel by removing four screws, three places for the two battery cables and the signal processor cable.
- f. Detach cable from signal processor mounting bracket, RTV-21105, and remove bracket.
- g. Remove simulated hinges, front and rear.
- h. Remove front and rear cover panels.
- i. Disconnect the steering tie rods from the quadrant gear.
- j. Disconnect the electrical plugs. Detach the two wires from the diode mounting block terminal strip.
- k. Remove the two gearboxes to isolation, mount bolts.
- l. Remove the two bolts and two screws from the large end of the gearbox.

NOTE: On the rear of the front unit the nuts on the two bottom vertical screws have to be removed. The ends of the screws are slotted for this purpose.



**DEPLOYMENT SEQUENCE**

- PULL "D" RING
- UPPER RELEASE PINS (2) ARE PULLED AND LOWER HALF OF APEX FITTING (2) ARE RELEASED (DETAIL C)
- UPPER RELEASE PIN PULLED, LRV NOW FREE TO ROTATE (DETAIL B)
- PULL RIGHT BRAKED REEL OPERATING TAPE (DETAIL B)
- DEPLOYMENT CABLES (2) PAY OUT ROTATING LRV 15°

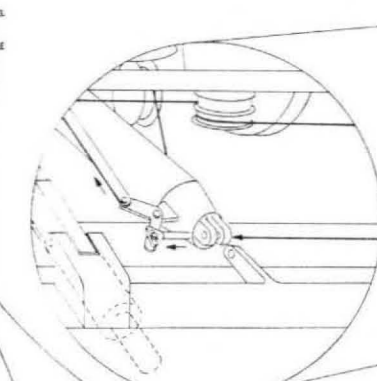

**DETAIL A**

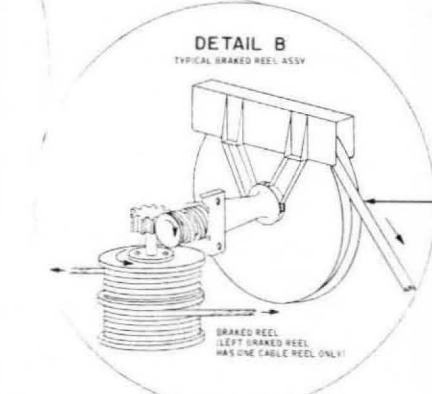

**DETAIL B**  
TYPICAL BRAKED REEL ASSY

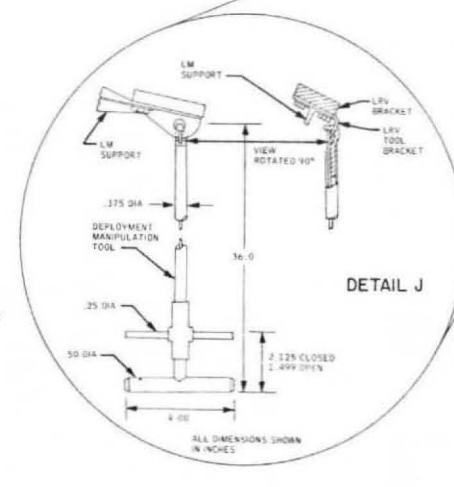

**DETAIL J**

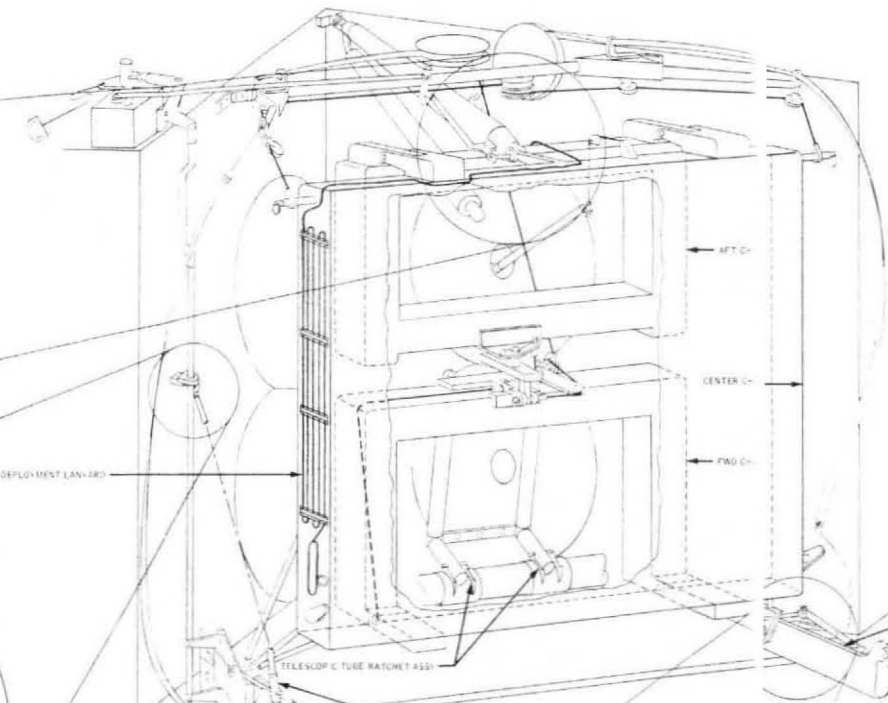

**DETAIL C**

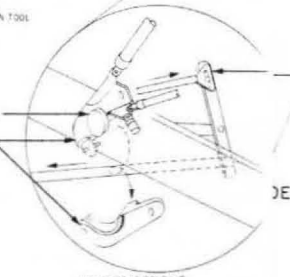

**DETAIL C**

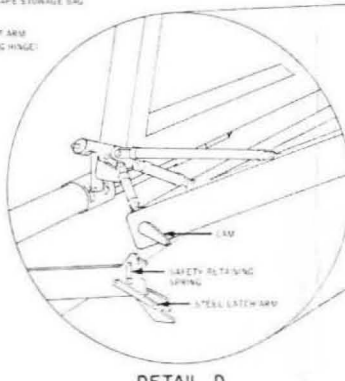

**DETAIL D**

- LRV CAM LATCHES IN SUPPORT ARM WALKING HINGE
- APEX FITTING LIFTS OFF SPOOLS (2) AT 15°
- PUSH OFF SPRING APPLIES FORCE TO LRV THRU THE FIRST 24° OF TRAVEL
- TELESCOPIC TUBE ASSY AND RATCHET ASSY ENGAGE PRIOR TO 40° TO PREVENT REVERSE ROTATION
- 45° CABLE TIGHTENS, ROTATING SADDLE PULLEY WHICH ROTATES TWO SMALLER PULLEYS RELEASING THE FORWARD AND AFT CHASSIS RELEASE PINS (DETAIL E)
- THE AFT CHASSIS IS FREE TO ROTATE 120° AT 110° THE AFT WHEEL LOCK STRUTS RELEASE THE WHEELS, BUT ARE RETAINED TO THE LRV BY TETHERS
- THE FWD CHASSIS IS RELEASED, BUT DOES NOT ROTATE DUE TO INTERFERENCE WITH LM STRUCTURE AT THIS TIME
- RIGHT BRAKED REEL IS OPERATED UNTIL LRV CENTER CHASSIS IS AT 75°
- LRV CAM ROTATES STEEL LATCH ARM RELEASING CAM FROM SUPPORT ARM (DETAIL C)

CONTINUED ON SHEET 2

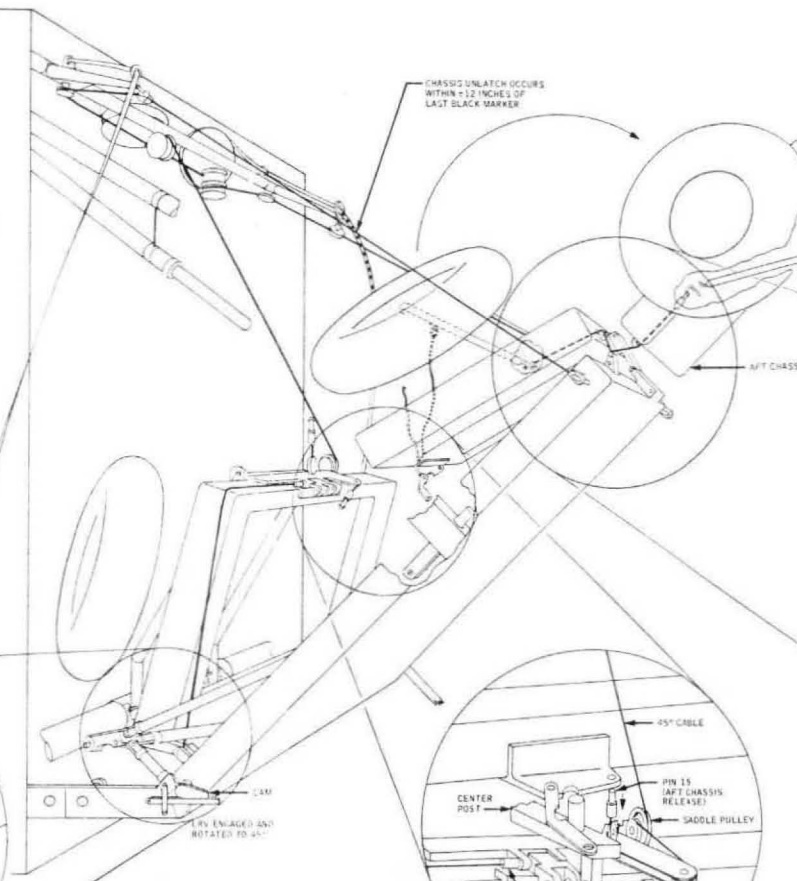

**DETAIL E**

**LRV SSE**

| SIGNATURES | DATE | NATIONAL AERONAUTICS & SPACE ADMINISTRATION |
|------------|------|---|
| DR         |      | MANNEK SPACECRAFT CENTER - HOUSTON, TEXAS   |
| DSGN       |      |   |
| GC         |      |   |
| ENGR       |      |   |
| APP        |      |   |
| REC        |      |   |

|           |                |        |              |
|-----------|----------------|--------|--------------|
| LRV       | D <sub>5</sub> | DWG NO | 93           |
| APOLLO 17 |                |        |              |
| 1/25 X 12 | PAGE           | 1-1    | SHEET 1 OF 2 |